

SOUND
REPRODUCTION

G. A. Briggs

SOUND REPRODUCTION

SECOND EDITION



G. A. BRIGGS

SOUND REPRODUCTION

by

G. A. BRIGGS

Author of "LOUDSPEAKERS; THE WHY AND HOW OF GOOD REPRODUCTION"

SECOND EDITION

Revised and Enlarged

*Where music dwells
Lingering, and wandering on as loth to die
Like thoughts whose very sweetness yieldeth proof
That they were born for immortality.*

Wordsworth.



Published by WHARFEDALE WIRELESS WORKS
BRADFORD ROAD · IDLE · BRADFORD YORKS

FIRST EDITION JULY 1949

SECOND EDITION MAY 1950



Copyright

Registered at Stationers' Hall

CONTENTS

	<i>Page</i>
Preface	7
Foreword to Second Edition	9
Acknowledgments	11
Illustrations	12
Abbreviations and Definitions	16

PART I: LOUDSPEAKERS

Chapter	1	Size and Shape of Cabinets	17
" "	2	Exponential Horns and Multi-speakers	38
" "	3	Density and Vibration	44
" "	4	Cabinet Lining	49
" "	5	Air Loading	52
" "	6	Frequency Range	62
" "	7	Analysis of Sound, and Frequency Doubling	69
" "	8	15 inch Speakers	75
" "	9	Directional Effects	77
" "	10	Ribbon Speakers	80
" "	11	Questions and Answers	84
" "	12	Delayed Resonances	93
" "	13	The Ear	97
" "	14	Free-field Sound Rooms	98
" "	15	Reproduction in Schools	102
" "	16	Intermodulation	105
" "	17	Dynamic Range and Tone Quality	110
" "	18	Crossover Networks	112

PART II: RECORDS

Chapter	19	Recording Systems	129
" "	20	Magnetic Recording	133
" "	21	Disc Recording	151
" "	22	Recording Characteristics	160
" "	23	Direct Recording	168
" "	24	B.B.C. Recording	172
" "	25	Sapphire, Tungsten-carbide and Diamond	177
" "	26	Needles and Grooves	183
" "	27	Needle Inspection	202
" "	28	Distortion and Tracking Error	203
" "	29	Surface and Motor Noise	207
" "	30	Pick-ups	215
" "	31	Signal to Noise Ratio	224
" "	32	Microgroove Recording	226
" "	33	Electronic Sound	236
Conclusion			241
Reference Tables, c/m, grammes, etc.			243
Index			244

ERRATUM

Page 224—Chapter 21 should read Chapter 31

PREFACE

This book was originally intended to serve as a small Supplement to my first booklet :—“Loudspeakers ; the Why and How of Good Reproduction”, in order to answer questions which had arisen and to give details of further tests which have been made.

It was, however, constantly being brought home to me that it is not possible to investigate the question of good domestic reproduction of sound without taking into account the role played by records and pick-ups. Apart from articles appearing in technical journals—mostly American—there is little or no literature on the subject, and an approach from the musical angle does not yet appear to have been made.

Also, there is far more uncertainty and controversy associated with records, pick-ups and needles than with loudspeakers. It is quite a common experience to find one reviewer praising the tonal quality of a certain record whilst another critic condemns it. As the quality of recording is a question of fact rather than opinion, one of the critics must be describing his equipment instead of the record. In short, a case for investigation is easily made out.

It was, therefore, decided to extend the scope of the book, and an approach was made to the leading Recording Authorities for information and support. I was more than gratified by the response. The B.B.C. Engineering Division, Decca Record Co., E.M.I., and M.S.S. Recording Co. gave me demonstrations of modern equipment, provided me with technical papers and special test records, and answered many troublesome questions with grace and candour, thus proving that they are quite as keenly interested in improving domestic standards of reproduction as are the listeners themselves.

It should also be stated that all the leading pick-up makers responded readily to my questionnaires, and I was more than a little impressed by the informative articles and leaflets which they issue. As a result, it was decided to curtail the description of commercial pick-ups as much as possible, so that pages were not taken up in giving the sort of information which is available from the makers on request.

Finally, I must express my appreciation of the personal and generous help—in all cases involving many hours of work—which has been given by the following gentlemen :—

PREFACE

Mr. F. Beaumont of Ambassador Radio for Technical corrections.

Mr. F. Keir Dawson for making over sixty drawings.

Mr. D. L. Hillman for highly involved mathematical calculations of acoustical reactance, etc.

Mr. F. W. James, for Treatise on Velocity and Transmission of Sound in different media.

Mr. A. Smith for collating data from Recording Authorities.

Mr. C. E. Watts for Photomicrographic Research Work.

The reader may by now be wondering where the author comes in, but most people will have some idea of the enormous amount of work entailed in compiling a book of this sort and presenting it in terms which are easily comprehended. All tests and experiments are very time-consuming, and I do not mind admitting that I spent the best part of a week on surface noise alone, with mostly negative results.

The main object of the book is to examine the problem of Sound Reproduction as a whole, from the view-point of musical appreciation under domestic or small hall conditions, with emphasis on fact in preference to opinion wherever possible.

As in the previous volume, the use of technical terms and radio jargon has been avoided as much as possible, but a list of abbreviations is included for reference and guidance where necessary. The only exception to the above rule is the use of the expression Kc/s, as it is so much quicker to write "5 Kc/s" than "5000 cycles per second".

G. A. BRIGGS

FOREWORD TO SECOND EDITION

In order to lower the cost as much as possible, an initial quantity of 10,000 copies of the first edition of "Sound Reproduction" was printed, and the price was fixed low with a view to recovering costs rather than making a profit. The risk of suffering a severe loss in the absence of a healthy demand for the book was correspondingly greater. Fortunately, the edition has been sold out in just over six months. Regular orders have been received from America, Canada, Australia, India—in fact from all parts of the world where English is spoken.

I was therefore faced with a problem: whether to have the book reprinted in its original form, or revise and enlarge it and bring out a second edition. It seems rather early for the second course, but many questions have been raised by readers which merit attention, further experiments have been made, and I feel that a revised edition is necessary. New chapters are included on

EXPONENTIAL HORNS AND	QUESTIONS AND ANSWERS
MULTI-SPEAKERS	CROSSOVER NETWORKS
CABINET LINING	MAGNETIC RECORDING
AIR LOADING	SAPPHIRE, TUNGSTEN-CARBIDE
DIRECTIONAL EFFECTS	AND DIAMOND
RIBBON SPEAKERS	NEEDLE INSPECTION

plus fresh information on Cabinet Size and Shape, Disc Recording, Needles and Grooves, Pick-ups and Microgroove Records—in all more than 100 additional pages with 75 new diagrams.

As the reproduction of sound is more an art than a science, it is hardly possible to produce a text-book that will cover the many variations of taste and conditions which arise. The chapter devoted to questions which have been received may help to clarify doubtful points for other readers, although in many cases the replies only represent an expression of opinion.

In addition to further generous help from the gentlemen and firms mentioned in the Preface, I should like to acknowledge the valuable assistance received from the following in the preparation of the new material for this Edition:—

MR. PETER DeVERE of Los Angeles.

HAWLEY PRODUCTS, LTD., of Tottenham, London.

MR. S. KELLY of Cosmocord, Ltd., Enfield, Middx.

MR. E. J. MARCUS of Tetrad Corporation, Yonkers, N.Y.

MR. H. A. MOYER of Astatic Corporation, Ohio.

MR. JAMES E. SPARLING of Columbia Records Inc., Connecticut.

MR. A. R. SUGDEN of Brighouse, Yorkshire.

One or two readers have complained that we (Mr. Watts and myself) have been unfair to fibre needles, but I think they have misunderstood the main objects of the investigations made by Mr. Watts, which are (1) the attainment of wide response with high quality, and (2) reduction of record wear. Item 1 must come first. On the other hand, a valuable collection of records—some of which may be irreplaceable and of limited frequency range—calls for special consideration, and the use of a soft stylus is indicated. It is only necessary to examine a fibred collection to see that wear is negligible.

Others have remarked that the book is patchy and lacks continuity. I agree, as no effort has been made to link the chapters together. The important thing is to have each section, or even each paragraph, clearly headed to facilitate reference.

I am well aware that these little books of mine break all the rules, and probably engender a feeling of dismay in the well-ordered mind of the professional technical writer. For instance, it is considered correct that technical literature should be written in the third person, yet I have ample evidence to show that the personal touch which has occasionally crept into these pages has been welcomed by the majority of readers. I have therefore succumbed to the suggestion of my youngest daughter that my photograph should be inserted, thus adding still more emphasis to the personal side.

There can be no reason to suggest that books dealing with sound and music should be devoid of humour, so we can only decide to continue with the mixture as before.

G.A.B.

May, 1950

SPECIAL NOTE.

With further reference to the photographs 73A and 73B, showing the very slight rate of wear on gramophone needles with $7\frac{1}{2}$ grammes weight, it should not be concluded that extremely-light weight is the complete answer to good record reproduction. There is often an increase in distortion on loud passages of music, as a result of unsatisfactory tracking, if the pressure is too light. The stylus must maintain good mechanical contact with the modulated groove, and it is advisable to use sufficient weight to ensure this condition, even at the cost of a slight increase in the rate of wear. The necessary downward pressure will of course vary with different pick-ups.

ACKNOWLEDGMENTS

The following list should be taken as an expression of indebtedness to authors and publishers for many facts and figures used in this book. Actual extracts or quotations are, of course, individually annotated, but it is no exaggeration to say that without the help afforded by these publications, or essays, the present work could not have made its appearance.

TECHNICAL ARTICLES

1. M. J. L. PULLING, M.A., M.I.E.E. "Sound Recording as applied to Broadcasting". *From B.B.C. Quarterly, July, 1948.*
2. H. DAVIES, M.ENG., M.I.E.E., "The Design of a High-Fidelity Disc Recording Equipment" (B.B.C.). *From Journal of I.E.E., July, 1947.*
3. G. F. DUTTON, PH.D., D.I.C. "Sound Recording and Reproduction" (E.M.I.). *From Discussion before Radio Section of I.E.E., February, 1944.*
4. W. J. LLOYD, B.SC., A.M.I.E.E. Paper on "Factors in the Reproduction of Gramophone Records".
5. F. W. JAMES, A.R.C.S., B.SC. Paper on "Sound; Some Electrical Analogies".

BOOKS

6. "The Oxford Companion to Music". P. A. SCHOLÉS.
Oxford University Press.
7. "Elements of Acoustical Engineering". 2nd Edition. H. F. OLSON.
D. Van Nostrand Co. Inc.
8. "The Physics of Music". A. WOOD. *Methuen & Co. Ltd.*
9. "Elektroakustisches Taschenbuch". RICKMANN & HEYDA.
Georg Neumann & Co.
10. "Electronic Musical Instruments". S. K. LEWER.
Electronic Engineering.
11. "Science and Music". SIR JAMES JEANS.
Cambridge University Press.
12. "Magnetic Recording". S. J. BEGUN.
Murray Hill Books Inc.
13. "Recording and Reproduction of Sound". O. READ.
Howard H. Sams & Co. Inc., Indianapolis.
14. "Elements of Sound Recording". JOHN G. FRAYNE AND HALLEY WOLFE.
John Wiley & Sons, Inc.

ILLUSTRATIONS—PART II

Fig.		Page
46	Film Recording	131
47	Philips-Miller Recorder	132
48	Poulsen's Telegraphone	133
48/1	Diagram of Tape Recorder	135
48/2	Wire and Tape Response	136
48/3	Coercivity and Response	137
48/4	Methods of Magnetisation	137
48/5	Gap and Response	138
48/6	" " "	139
48/7	Triple Head	139
48/8	Gap Width	140
48/9	Speed and Response	141
48/10	Remanence Curve	143
48/11	D.C. Bias	143
48/12	" " "	144
48/13	H.F. Bias	145
48/14	" " "	145
48/15	Bias and Response	146
49	E.M.I. Tape Recorder	148
50	<i>Cancelled</i>	
50/1	Excel Tape Recorder	149
50/2	Sound Magnet Recorder	150
51	Edison Phonograph	151
52	Berliner Gramophone	152
53	Soundbox	153
54	" Response	153
55	Re-entrant Gramophone	154
55/1	Accoustical Recording	155
55/2	" " "	155
55/3	Dusty Record	158
56	Decca Recording Characteristic	160
57	B.B.C. and N.A.B. Characteristic	161
58A	Response and Tracking Radius	162
58B	Radius Compensation	163
58C	Amplifier Response Curves	165
58D	Buchmann-Meyer Pattern	166
58E	" " "	167
59A	New Lacquer Disc	169
59B	Lacquer Disc after 50 Playings	170
59C	" " " 1 Playing	171
60	Cutting Speed and Diameter	173
61	B.B.C. Disc Recording Channel	174
61A	B.B.C. Turntable Drive	174
62	Response B.B.C. Records	175
62/1	Surface Porosity	178
62/2	Shadowgraph Inspection	178
62/3	Abrasive Tests of Shafts	180
62/4	" " " Points	180
62/5	Diamond Point	182
63	Needles and Grooves	183
64	Wavelength/Frequency/Speed	184
65	Groove/Needle/wavelength	185
66	" " "	186
67A	New Fibre Needle	187
67B	Used Fibre Needle	188
68	New Steel Needle	189
69	Used Steel Needle	189
70	New Sapphire	190

ABBREVIATIONS

A	Ampere.	HF	High frequency.
AF	Audio frequency.	Kc/s	Kilo-cycles per second (1000 ~)
AM	Amplitude modulation.	L	Inductance.
AC	Alternating current.	LF	Low frequency.
BA	Balanced armature	LP	Long playing.
C	Capacitance.	mH	Milli Henry
~	Cycles per second.	mil or m	Milli (one thousandth).
cps. or c/s	Cycles per second.	Mfd (μ F)	Microfarad.
db	Decibel.	μ (μ)	Micro (one millionth).
DC	Direct current.	NAB	National Association of Broadcasters (American).
EMF	Electro-motive force-Volts.	RMS	Root mean square.
FD	Flux density or Gauss.	RPM	Revolutions per minute.
FM	Frequency modulation.	V-Volt	W-Watt Z-Impedance.
FF	Full frequency.		
H	Henry.		

DEFINITIONS AND SYNONYMS

- Armature (pick-up)—Needle-holder or needle.
Anechoic—Without echo.
Cutting speed—Surface speed.
Dynamic pick-up—Armature or coil vibrates in magnetic field.
Exponential—Flare increasing at logarithmic rate.
Flux density—Lines of force in a magnetic gap.
Free-field room—Anechoic or dead, and soundproof.
Frequency doubling—Generation of harmonics in cones.
Fundamental—Lowest frequency in a complex tone, i.e. the first partial or harmonic.
Gauss—Flux density.
Harmonic—Multiple of fundamental, e.g. third harmonic of 100 cycles is 300 c.p.s. (Second overtone).
Magnetic pick-up—Armature attracted by magnetic force.
Modulation—Of record—Sound waves impressed on groove walls.
Partial—Harmonic.
Pressing—Moulded record as distinct from direct recording.
Processing—Sequence of operations from direct recording to production of pressing.
Stamper or Matrix—Metal disc from which record is moulded.
Surface speed—Speed at which groove passes under needle.
Timbre—Tone—Harmonic structure.
Tracing—Stylus following modulation of groove.
Tracking—Passage of cutter or stylus across disc.
Vacuum tube—Valve.
Wow—Slow changes of pitch as record rotates, due to changing speed.

Part 1

LOUDSPEAKERS

Part I of this book should be considered as a continuation of the Loudspeaker booklet already mentioned in the preface. Many interesting questions were raised by readers, and as the problems of good domestic reproduction of sound are of comparatively recent origin and are still to some extent unsolved, it is not surprising that further investigations have justified the writing of new chapters on the subject.

CHAPTER I

SIZE AND SHAPE OF CABINETS

The question is often asked: "What are the correct dimensions of a cabinet for a certain speaker unit?" Unfortunately, there is no direct answer. It is appreciated that a feeling of confidence and satisfaction is experienced by the amateur who contemplates making a Reflex cabinet and is told by the professional exactly what to do for best results, even down to the last half inch. This atmosphere of finality is greatly to be desired, but the writer regrets his inability to foster it because his experience points to the conclusion that loudspeaker cabinets are like Canadian lettuce—the bigger the better.

It is admitted that there is a balanced size of Reflex cabinet where cone and air-column resonances coincide, and such a chamber gives far better results than a smaller size with the same unit. But it can be proved that a still larger air cavity gives still better quality, with lower harmonic distortion from frequency doubling. It is therefore a misnomer to talk about correct size in such a case.

The most satisfactory approach to the question appears to be an examination of what actually happens when size and shape are altered, and this line is taken in the present investigations. The reader may then decide sizes himself, according to materials and space available.

AIR LOADING AND RESONANCE

The effect of cabinet change on bass resonance is clearly shown in Fig. 1, where the same 12" unit is used in each of the three tests.

Curve A shows the pronounced fundamental resonance at 50 cycles with open back cabinet with no air column resonance. Curve B shows the result of converting the cabinet to Reflex. This introduces air column resonance at 90 and pushes the cone resonance down to 38 cycles. The general effect is coloration of speech at 90 cycles, but deeper bass in music. The third test C shows a marked lowering of the air column resonance, with the cone resonance still as low as

SIZE AND SHAPE OF CABINETS

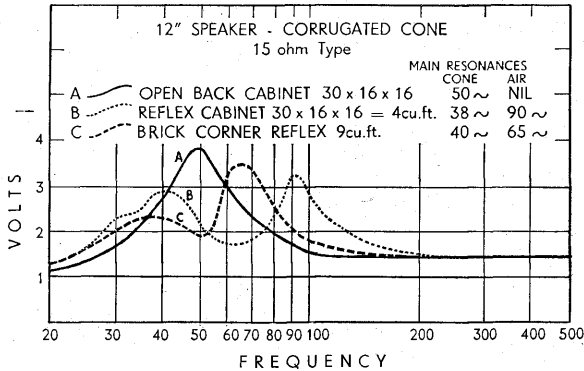

FIG. 1.—Bass Resonance.

40 cycles, giving better quality of speech and music than either of the two previous systems, due to extra size and rigidity.

REFLEX CABINET SHAPE

It is usually convenient to make a Reflex cabinet with its height about twice as great as the width. The effect of altering the shape to a cube of the same volume was tried, with the following results, Fig. 2A to 2D.

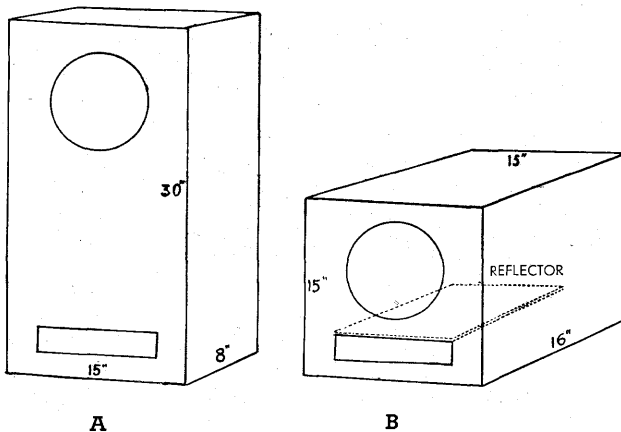

FIG. 2A and 2B.—Reflex cabinets with 8" unit. Same volume—different shape.

MAIN RESONANCES

	A		B	
	Cone	Air	Cone	Air
Port open	45	75	58	110 cycles
Port closed	80	80	95	95 "
Port open	—	—	R48	105 "

R with internal reflector.

This test proves that theoretical calculations of matched resonances (cone and air) cannot be based on cubic capacity of cabinet without taking into account the shape. As expected, the shorter air column of B gives a higher resonance than A. Inserting a reflector through the port B, a distance of 10/12", lowered both resonances and gave much improved results on speech and music. In fact, the use of a Reflex chamber of square shape, with a partition across the full width, as in Fig. 2C, may well give better results than the more common design of Fig. 2A, owing to the larger volume of air immediately seen by the back of the cone.

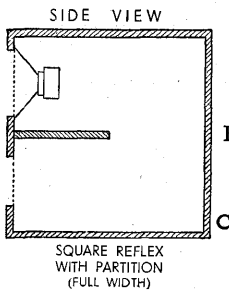

FIG. 2C.—Side view of suggested Reflex cabinet with full width reflector.

An arrangement on these lines would permit excellent Reflex loading in a space of unusual shape, and there must be many odd corners and recesses in existence which could easily be adapted for acoustic purposes, giving results far superior to ordinary wireless cabinets. The function of the partition is to lengthen the air column and lower the resonance, just as an organ pipe is bent or folded to reduce its outside dimensions and save space. Such bending or folding back makes no difference to the pitch (or resonant frequency) of the pipe.

SQUARE SHAPE AND BASS

It is noticed that the cubic shape sounds better in the extreme bass than its taller counterpart, and as the square design is often used for infinite baffle effect, a harmonic analysis of output at 30 and 50 cycles was made with the square cabinet of Fig. 2B. With the tall cabinet of Fig. 2A, only harmonics were produced with 30 cycle input, so

SIZE AND SHAPE OF CABINETS

that curve A—bad as it is—may be considered better than average. The totally enclosed conditions B and E show the best analysis, but the fact remains that for all-round reproduction the open port and partition would be best (see Fig. 2D).

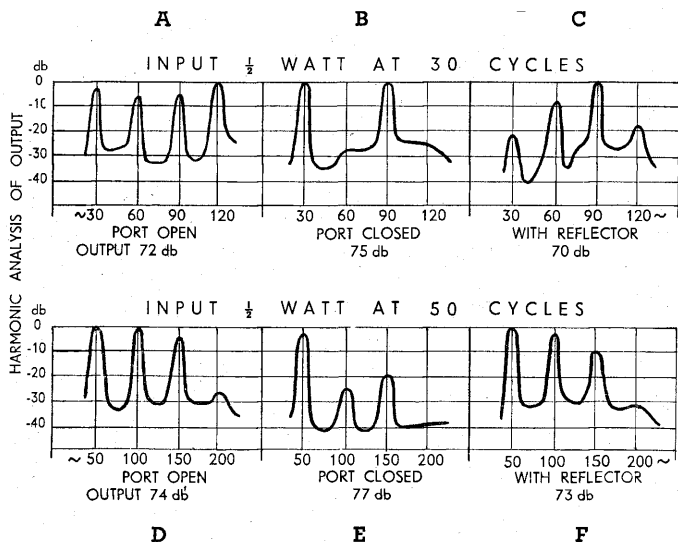

FIG. 2D.—8" unit in square cabinet.

Harmonic Analysis at 30 and 50 cycles.

It is appreciated that 30 cycles is a very low note for any 8" speaker to tackle, and even 50 c.p.s. is asking rather a lot, but the tests are designed to show the influence of air loading under adverse conditions. The indications are that the totally enclosed cabinet is attractive where extreme bass response is the main consideration. The output figures in db represent the total sound under live room conditions, including harmonics. Harmonic analysis of larger units will be found in Chapter 7.

UNUSUAL SYSTEMS

Many unconventional methods of mounting have been tried, and two reports are now given as a guide to those who may wish to use odd cabinets or spaces (Fig. 3).

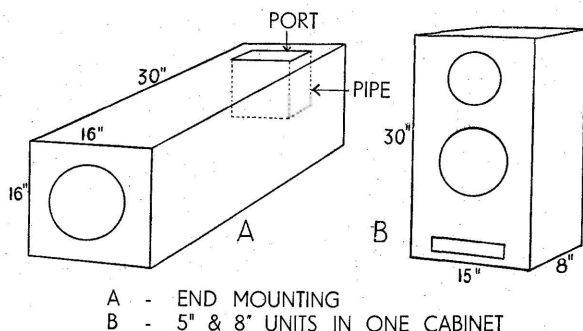

FIG. 3A and 3B.

An 8" unit with open resonance of 68 cycles was mounted in the end of Cabinet A with the following results :—

CABINET A—Main resonances

	Port 11 × 3"	With 8" pipe	Port closed
Cone	45	35 cycles	75
Air	80	70 "	75

In spite of these satisfactory readings, the tone was not liked for single speaker reproduction; results are improved by adding an extra unit for treble on small open baffle.

Two units were mounted in parallel in Cabinet B of Fig. 3, and gave very loud results with strong resonances. The arrangement can only be recommended where volume or loudness is the main requirement.

REFLEX WITH PIPE

Designs are often shown with a pipe or tube fitted to the port and extending several inches into the air chamber. This is a device for lengthening the air column and lowering the resonance. Tests were put in hand with a view to tabulating the actual effect of such pipes, but results varied enormously, according to conditions, and it was found necessary to make between 70 and 80 different tests before any common denominator could be found. Details of results from 8" and 10" units in two sizes of cabinet now follow (Fig. 4) :—

The pipe is made an airtight fit to port, and extends inwards to about half the depth of cabinet.

Tests made with 8" unit with open resonance of 68 cycles and 10" cloth surround unit of 58 cycles.

SIZE AND SHAPE OF CABINETS

REFLEX CABINETS (SIDE VIEW)

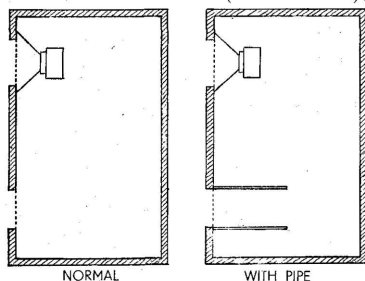

FIG. 4.

DETAILS OF TESTS—MAIN RESONANCES

	Cabinet 30" × 16" × 12"				Cabinet 30" × 15" × 15"			
	8" unit				8" unit			
	Port	With	Port	Port	Port	With	With	Port
	10" × 3"	7" pipe	6" × 3"	3" × 3"	11" × 4"	6" pipe	8" pipe	Closed
Cone	50	45	42	37 ~	44	36	34	70 ~
Air	90	80	85	80 ~	75	73	72	70 ~
	10" unit				10" unit			
	Port	With	Port	Port	Port	With	Port	
	10" × 3"	7" pipe	6" × 3"	3" × 3"	11" × 4"	8" pipe	11" × 1"	
Cone	44	47	40	38 ~	40	30	30 ~	
Air	85	78	80	78 ~	78	70	75 ~	

T—see Test report after main deductions.

It will be observed that with both units the extra 3" in the depth of the cabinet gives a better performance in the shape of lower resonances.

The main deductions are as follows :—

1. The addition of the pipe to cabinets of medium size does, in general, lower the frequency of the air column resonance.
2. Reduction of port area to best size is more effective than use of pipe in lowering cone resonance.
3. In some cases the pipe actually raises the cone resonance, while lowering the air resonance.
4. The port area for lowest cone resonance is very small—only about 10 square inches in cabinets of 3-4 cubic feet. Closing this small vent raises the cone resonance by almost an octave.
5. Fitting a pipe to 9 cubic ft. enclosure made no difference to the performance of a 12" unit.
6. The importance of airtight cabinets should be stressed. It was found necessary to seal all joints around the back with adhesive tape for every test, thus using up a lot of time as well as a lot of tape. The sealing often makes a difference of 10% to results, but becomes less important as cabinet size is increased.

LISTENING TEST

The inevitable question is now "What will you have—a small port or a pipe?" Socially a strange choice, but a pertinent one in the present investigation. Two identical cabinets were fitted with similar 10" units as at T on previous page. One port was fitted with 7" pipe and the other port was reduced to 3" × 3". The difference in reproduction was only slight, and preferences varied according to items heard.

Later tests with pipe are outlined in the section on Matched Resonance at the end of this chapter.

SIZE OF OPEN CABINETS

Some interesting illustrations of the effect of cabinet design on frequency response are given in the Second Edition of Olson's "Elements of Acoustical Engineering", a text-book which contains a mine of information on all aspects of electronics and sound. The first set, Fig. 5, illustrates the effect of cabinet size apart from cone resonance, as the tests were made with a loudspeaker having a resonant frequency of 20 cycles, which is equivalent to a non-resonant source.

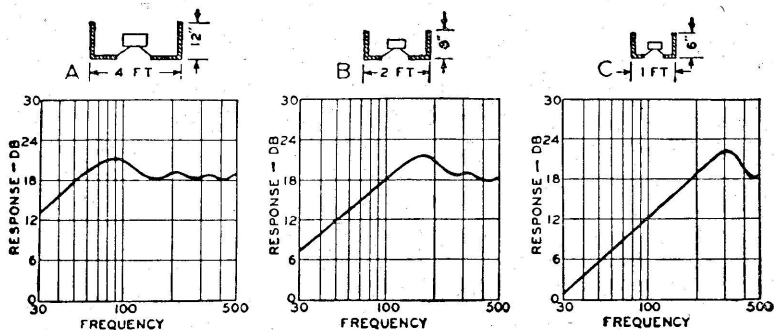

From Olson's "Elements of Acoustical Engineering"

FIG. 5.—Pressure response frequency characteristics of mass controlled, direct radiator, dynamic loudspeaker mechanisms with 10-inch diameter cones mounted in square open-back cabinets. A—Cabinet, 4 feet × 4 feet × 12 inches in depth. B—Cabinet, 2 feet × 2 feet × 8 inches in depth. C—Cabinet, 1 foot × 1 foot × 6 inches in depth.

It will be noted that the response falls off at the rate of 6 db per octave according to size of cabinet. Had the tests been made with a speaker having a cone resonance at, say, 100 cycles, the drop in response below this frequency would have been at the rate of 12/18 db per octave.

CABINET DEPTH

The effect of increasing the depth of an open back cabinet is shown in Fig. 6.

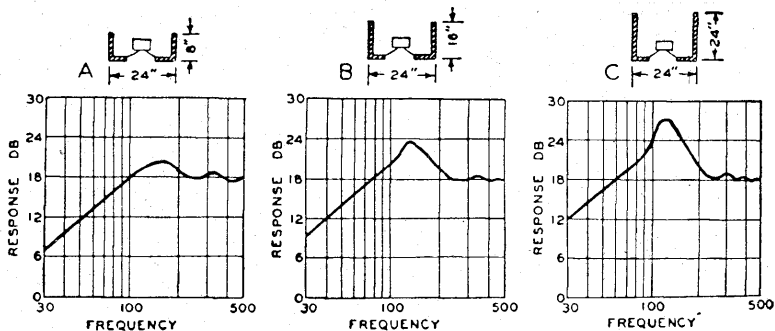

From Olson's "Elements of Acoustical Engineering"

FIG. 6.—Pressure response frequency characteristics of mass controlled, direct radiator, dynamic loudspeaker mechanisms with 10-inch diameter cones operating in open-back cabinets 2 feet x 2 feet and the following depths : A—8 inches. B—16 inches. C—24 inches.

The same low-resonance units as in Fig. 5 were used, and the increased humps in the response amply confirm what is normally heard with deep-sided cabinets.

CABINETS—OPEN, CLOSED, REFLEX

A third example is included as a comparison of the type of response to be had from cabinets of different design but identical size, Fig. 7.

The tests of Fig. 7 were taken with a speaker with a cone resonance of 30 cycles. Consequently no cone resonance is shown in the curves, and these results would not be possible with ordinary units with resonances around 80/100 cycles. As regards the totally enclosed cabinet, Fig. 7B, the improved L.F. performance tallies with results described in connection with Fig. 2D earlier in this chapter, and also with the improved 30 cycle results described later, in Chapter 7, Analysis of Sound and Frequency Doubling. Even so, it would be a mistake to assume that the totally enclosed cabinet is the best merely because it has the best curve. The question of life and colour in the tone of reproduction must also be considered.

As regards the Reflex tests of Fig. 7C, the effect of reducing area of port to best size is interesting, and confirms the writer's own experience.

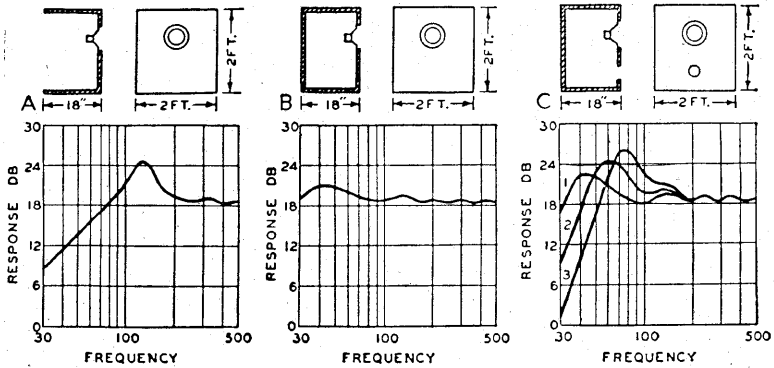

From Olson's "Elements of Acoustical Engineering"

FIG. 7.—Pressure response frequency characteristics of a direct radiator, dynamic loudspeaker mechanism with a 10-inch diameter cone and a resonant frequency of 30 cycles operating under the following conditions: *A*—Open cabinet, 2 feet \times 2 feet \times 18 inches in depth. *B*—Closed cabinet, 2 feet \times 2 feet \times 18 inches in depth. *C*—Phase inverter cabinet, 2 feet \times 2 feet \times 18 inches in depth and various port openings; 1.—Small port. 2.—Medium port. 3.—Large port.

In describing these tests Dr. Olson states: "Cabinet resonance is eliminated by the phase inverter system". Presumably, Dr. Olson refers to the humps shown in the response curves of open back types. It should, however, be borne in mind that Reflex loading introduces air column resonance which, under some conditions, may be far worse than the open back effect. Our own tests with 5" unit in a matched Reflex cabinet were disappointing, with prominence in the octave above 80 cycles. It is considered advisable to restrict the Reflex system to speakers with low cone resonance and adequate air loading, to improve the response below 80 cycles.

HIGH NOTE SYSTEMS

As regards high note reproduction, any form of boxing-in should be avoided as much as possible. For frequencies above 1000 cycles, a small open baffle with back of speaker reflecting into a corner, is hard to beat. This arrangement overcomes the point-source effect which worries many listeners, and while not achieving the efficiency of horn loading, is much cheaper and easier to install. The system also avoids the emphasis on certain frequency ranges associated with exponential horns, unless correctly designed to cover the ranges involved. Uniform response over $8\frac{1}{2}$ octaves, from 30 to 12,000 cycles, with horn loading, which require three different rates of flare.

BAFFLES

It is well known that the shape of a baffle and the placing of the speaker opening have an important effect on the response. The following diagrams, Fig. 8, are of interest, and show the improvement effected under free-field conditions by avoiding a uniform path length from back to front of speaker.

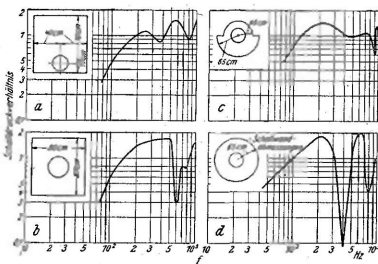

- a. Baffle 35" × 32" unit off centre.
- b. Baffle 35" × 32" unit centrally mounted. Dip in response at 600 cycles.
- c. Small radius 18". Wide " 25½".
- d. Circular baffle 51" diameter. Unit in centre. Severe dip at 400 cycles.

FIG. 8.

*From Elektroakustisches Taschenbuch
G. Neumann & Co., Berlin*

The worst response comes from the most uniform shape at *d*. Although the effect of baffle shape is not so pronounced under live room conditions, an arrangement on the lines of the circular baffle *d* would give a hollow, unnatural type of reproduction.

MATCHED RESONANCE

Further tests with Reflex Cabinets designed to match the cone resonance have been carried out. The difficulties are enormous, and it is doubtful if success could be achieved under domestic conditions. The approach to good reproduction via low cone resonance and no cabinet resonance offers a surer foothold and a more certain destination.

The protagonists of matched resonance usually work on the following assumptions :

1. That the matching of resonance is a fundamental of good design.
2. That port area should be the same as radiating surface of the speaker.
3. That the effective size of the cabinet is increased by as much as 50 per cent. by extending the port inwards by fitting a pipe.
4. That transient reproduction is improved by matched conditions.

Let us examine these assumptions in turn.

1. If this is really true, the majority of the reflex cabinets in use today must be either wrongly designed or be fitted with units of high cone resonance. The main obstacle to matching is the increase in size of cabinet which is required for low cone resonance. As regards results, I know one recording engineer who fits a 15 inch unit in a ceramic case of 3 cu. ft. weighing about 100 lbs. The cone resonance is 25 cycles and the air is about 90 c.p.s. but organ reproduction is very fine.
2. It is difficult to think of a reason why the port area should not be altered to suit requirements.
3. Once the best size of port is arrived at, there is no use in fitting a pipe. It is much easier to reduce the size of the port than to fit a pipe, and so far as the writer's experience goes, the results are the same.
4. This is certainly true. The transient response is far better under matched conditions and is probably equal to the best horn loading. In the writer's opinion, it is the most striking effect of true matching, but does not justify the acceptance of high cone resonance. For professional or commercial purposes, a large cavity matched to a cone resonance around 30 cycles would be an attractive proposition.

The following tests were made in an attempt to throw some light on the problem from the practical side.

Three reflex (plywood) cabinets of different height but identical in all other respects were constructed, Fig. 9/1, to find out the actual effect of variation of air column length.

FIG. 9/1 REFLEX CABINETS
OF DIFFERENT HEIGHTS

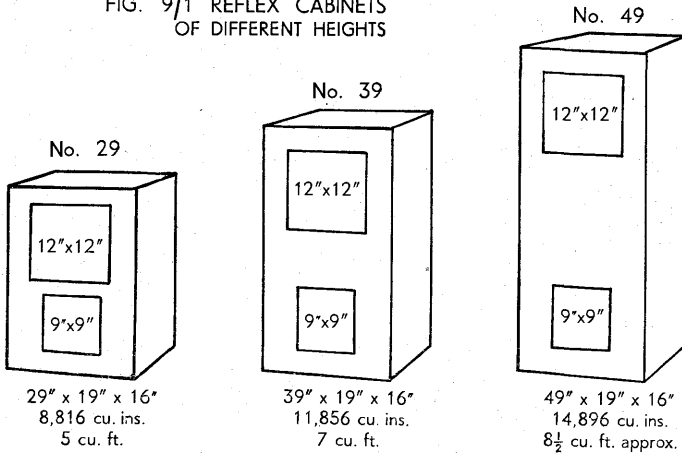

SIZE AND SHAPE OF CABINETS

The cabinets are numbered according to height to facilitate reference. Square openings were made so that any speaker mounted on a baffle could be instantly inserted from the front, and a pipe with Square flanges could be inserted with equal ease through the port. Various types of speaker were tried, with the following results. (The open baffle cone resonance is stated after each unit.) The 10" 48 cycle unit was fitted with cloth surround.

Cabinet	Port	8" 78~ Cone Air	10" 75~ Cone Air	10" 65~ Cone Air	12" 65~ Cone Air	10" 48~ Cone Air
No. 29	9" x 9"	70 90	80 95	45 75	45 76	36 70
No. 29	9" x 1"	78 85	80 88	40 70	30 70	32 62
No. 39	9" x 9"	70 80	80 70	45 65	42 68	35 60
No. 39	9" x 2"	80	80 70	36 62	33 66	30 52
No. 49	9" x 9"	65	90 68	55 65	37 52	31 50
No. 49	9" x 3"	63	88 70	58	30 54	28 50

Main Resonances.

In all cases, fitting an 8" pipe had a similar effect to reducing port to the minimum size stated.

The cone and air resonances are matched where only one frequency is mentioned. The main deductions are as follows:—

- It is much easier to find a match for 8" units than for larger speakers.
- The tallest cabinet generally gives the lowest resonances. The peculiar behaviour of the 10" 75 cycle unit is difficult to understand, but is probably due to air resonance being below cone resonance in cabinets 39 and 49.
Cabinet vibration was worst in the tallest Cabinet, No. 49.
- The frequency of cone resonance rises as the condition of matched resonance is approached.
- In some cases it is extremely difficult to determine which is cone resonance and which is air resonance.
- In view of enormous variation of resonant frequency with change of unit it is not possible to classify cabinets in terms of main resonance.
- Cabinet 49 was originally built to match a 12" 65 cycle unit. It was found to match a 10" 65 cycle unit at 58 c.p.s. with 8" pipe or 9" x 3" port. No amount of "tuning" would bring the 12" resonances together. Lining the Cabinet with $\frac{1}{2}$ " Weyroc

made it impossible to match the 10 inch unit. Correct volume is therefore important in some cases. The 8" unit would still match.

- (g) It was found possible to match an 8" unit (78 cycles cone resonance) to various conditions as follows :

	Cabinet	Port	cu. ft.	Matched Resonance
8" Unit in	30"x15"x14"	11"x 3"	3½	80 c.p.s.
" "	No. 39	9"x 2"	7	80 "
" "	No. 49	9"x 9"	8½	65 "
" "	No. 49	9"x 3"	8½	63 "
" "	*Brick	9"x 9"	9	78 "

- (h) It was at first concluded that an 8" unit in large cavity could not dominate the air—hence only one resonance—but an 8" unit with cloth suspension (60 cycles) was tested in the 9 cu. ft. brick enclosure and gave resonances of 42 cone and 58 air, incidentally with better quality of reproduction than the 78 cycles matched unit.
- (i) Where the two main resonances are less than 10 cycles apart, they can usually be pulled together by tuning the port.

10 INCH UNITS

A ten inch unit of 78 cycles open resonance was matched to the 3½ cubic ft. cabinet (already matched to 78 cycle 8" unit) by reducing port area to 11"x 1". The same 10" unit matched the 9 cu.ft. Brick enclosure at 78 cycles.

Reversing the baffle so that the unit was placed outside the air chamber (cone facing inwards) resulted in cone resonance at 78 and air at 80 cycles. A similar 10" 65 cycle unit in Brick enclosure gave the following results :

	Resonances	
	Cone	Air
Speaker inside	40	60
Speaker outside	45	62

The volume of air taken up by a 10" Speaker in a 9 cu. ft. enclosure therefore makes a difference of about 3 per cent. to the air column resonance.

12 INCH UNITS

The writer regrets he has not yet succeeded in matching a twelve inch (or 15 inch) unit to a reflex resonance. Something in the nature of a telephone call box would probably do the trick.

*For Brick Enclosure see Fig. 30, p.75.

IMPEDANCE

It is often assumed that matching the resonance reduces the peak, but this is not always the case, as the following details show:—

8" Unit, 2 ohm Resistance.

On small baffle, 14" square,
Mounted in Wall
In Cabinet No. 29

In Cabinet No. 39

In Cabinet No. 49

Peak Impedance.

17 ohms at 78 c.p.s.

13 " " 70 "

11 ohms at 75 c.p.s. and

10 " " 85 "

14 ohms at 80 c.p.s.

10 " " 65 "

Cabinets 39 and 49 represent matched conditions, but there is a difference of 4 ohms between them.

The following impedance curves give a basis of comparison between matched and unmatched conditions with two types of 10" unit, Fig. 9/2.

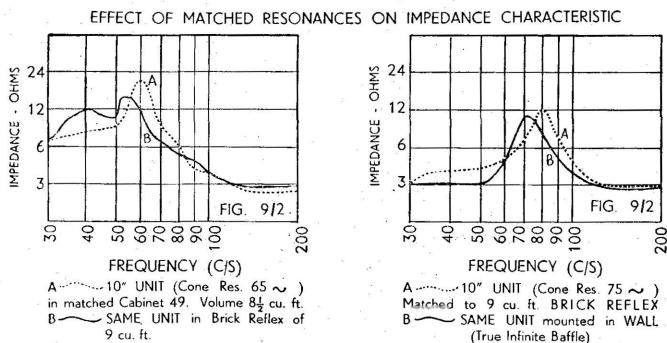

FIG. 9/2. Impedance—matched Resonance.

These tests indicate that the question of intensity of resonance peaks is neither uniformly nor vitally affected by matched conditions.

LOCATION OF AIR RESONANCE

An effort was made to locate the natural air resonance of the large cabinet No. 49, (8½ cu. ft.) and the Brick enclosure (9 cu. ft.) by a search with small speakers (5" and 6" units) and oscillator, but no useful peak could be found. Fig. 9/3 shows the strong effect of plywood resonance in cabinet 49, compared with non-resonance of brick, and Fig. 9/4 gives a vibration reading taken on side of cabinet

49. The main vibration peaks coincide with the response peaks of Fig. 9/3A.

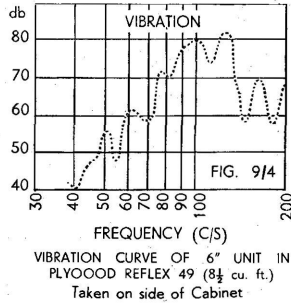
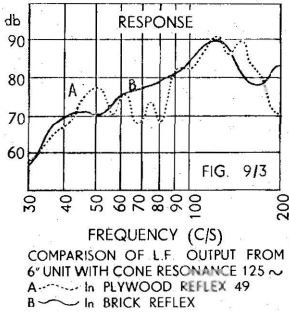

FIG. 9/3. Reflex—Resonance Curves.

FIG. 9/4. Reflex—Vibration Curves.

The conclusion here is that it is not feasible to classify large cavities in terms of natural resonance of enclosed air for matching purposes, and that cabinet vibration is a really serious menace in large structures.

The general rise towards 125 cycles is of course due to cone resonance and should be ignored in this case.

L.F. OUTPUT

The following diagrams, Figs. 9/5 and 9/6, give an indication of low frequency output from matched and unmatched conditions.

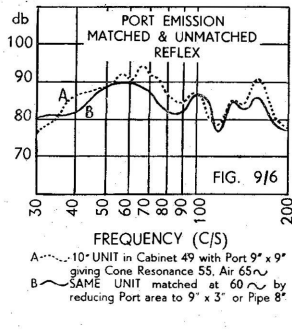
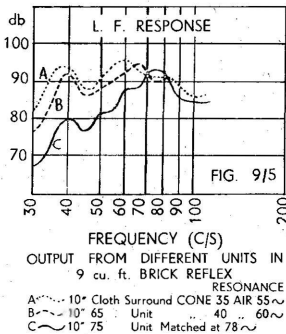

FIG. 9/5 Reflex—L.F. Response.

FIG. 9/6. Reflex—L.F. Response.

It will be seen from Fig. 9/5 that low frequency output is improved by low cone resonance, and this is confirmed by listening tests. In

the case of Fig. 9/6 the condition B would be preferred to the slight mismatch of A. The peaks at 100 and 150 cycles are due to plywood resonance already exposed in Figs. 9/3 and 9/4.

INTERNAL PIPE

This has already been described earlier in this Chapter, Fig. 4. There can be little doubt that the slightly different effects between very small port and internal pipe are due to the slight displacement of air caused by insertion of pipe. Lengthening the pipe and bending upwards merely obliterates all reflex action through the port and is equivalent to closing the opening for infinite baffle effect, plus the disadvantage of wasting materials and internal space.

POSITION OF PORT

In some designs the port is placed near the speaker opening to act as a reflecting plane at low frequencies, but as the floor acts as a reflecting plane when the port is placed near the bottom of the cabinet there would appear to be six of one and half a dozen of the other.

A test was made in the tall and much abused cabinet No. 49. Raising the position of the port made no difference to the air column resonance, but the cone resonance was lifted from 30 cycles to 35 c.p.s. using a 12" unit with cloth surround. The low position of vent or port is therefore preferred.

COAXIAL SPEAKERS

Reflex loading lends itself admirably to the coaxial type of speaker, where the high frequency response is extended by a special diaphragm, usually horn loaded. This helps to balance the increased low frequency output which is attained by reflex loading. A single speaker of average response often sounds too deep in tone when mounted in a reflex cabinet. In all cases of reproduction, the first essential is to achieve a reasonable balance between the two extremes of the available frequency range.

This question of balance is of more importance than the actual range. Any extension of the H.F. response, or any improvement to H.F. efficiency in the speaker, justifies similar improvement to the L.F. output.

It must be admitted that the problem of resonance in vented

enclosures is a very complicated one, and these notes hardly do more than touch the fringe of it. A more scientific approach by way of electrical analogy is really required along with acoustic tests, and the following American articles are recommended to those interested in the theoretical and technical aspects.

“Resonant Loudspeaker Enclosure Design”, by F. W. SMITH, *Communications*, Aug. 1945.

“Vented Loudspeaker Enclosures”, PLANER & BOSWELL, *Audio Engineering*, May 1948.

The mathematical equations on which these articles are based are not suitable for inclusion in a non-technical book of this nature. There is certainly some analogy between resonant circuits in acoustics and electronics, but acoustical resonance seems to me to possess some peculiarities of its own.

All the set-ups described in this section have been given a normal listening test and in all cases the low resonance results are preferred to matched resonance at higher frequency. The “judges” are two or three members of my staff who are gifted and experienced in the art of tonal discrimination and who disagree with me when they feel like it. Consulting the average listener or yes-men in such cases is a gross waste of time.

CHEAP NON-RESONANT REFLEX

Excellent results are possible on the following lines. Take two plywood baffles and fix them together about $\frac{1}{2}$ " to 1" apart (according to size), and fill the space with sand. Leave side openings, as shown in sketch, to clear skirting board and to serve as reflex ports. Place the sand-filled panel across the corner of the room and fit a top made of $\frac{3}{4}$ " ply or 1" solid timber, or any rigid material.

Useful sizes are as follows :

				Suitable for speakers
30" wide x 30" high	= 4 cu.ft.	$\frac{1}{2}$ " sand		up to 8" diameter
30" " x 36" "	= $4\frac{3}{4}$ "	$\frac{3}{4}$ " "	" "	10" "
30" " x 40" "	= $5\frac{1}{4}$ "	$\frac{3}{4}$ " "	" "	12" "
36" " x 40" "	= $7\frac{1}{2}$ "	1" "	" "	15" "

Such panels are free from resonance, sand is cheap and plentiful, and the construction is much easier than concrete or plaster lining (suggested in the first edition).

If the bass is inclined to be overpowering, or if reproduction of speech is thick and heavy, a space between the lid and the walls will relieve the pressure. I should ignore purists who say (rightly) that true reflex loading requires airtight conditions and adopt the arrangement which sounds best. Whatever is done will be a compromise.

One big advantage of this type of corner assembly is that the user can always add a treble speaker at a later date, connected either in parallel or with a crossover network. The extra speaker should be mounted on a small open baffle, with back radiation reflected from the corner of the room. The improved "top" thus achieved may well justify intensifying the airtight loading on the bass unit.

TAPERED PIPE

Another interesting form of mounting is the Tapered Pipe, as shown in the following sketch :

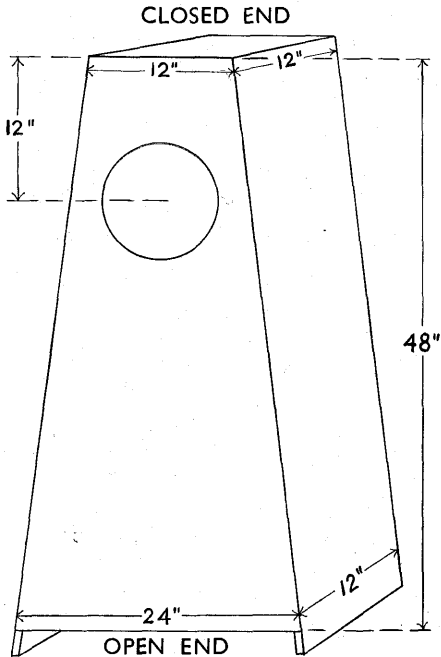

FIG. 9/8.—Tapered pipe.

SIZE AND SHAPE OF CABINETS

I am indebted to Ralph West, B.Sc., A.M.Brit.I.R.E. (Lecturer at Northern Polytechnic, London) for this design, which is based on Voigt's patent on quarter wave mounting. The general tone of reproduction is very much brighter than Reflex loading, and the efficiency, in terms of acoustic output, is extremely high. Less high frequency energy appears to be absorbed inside the cabinet: the tapered shape favours this, and also spreads the resonance in the bass. These conditions, combined with the absence of felt lining, result in a much larger volume of sound than is produced in most other systems. A pipe 5' long will give a fundamental resonance of about 45 to 50 cycles with a suitable 8" unit.

Mr. West certainly produces remarkable results.

ACOUSTIC ABSORPTION

This may be applied by packing the interior of the cabinet with cottonwool or other substances, or by using a system of spaced baffles; but it should be remembered that true absorption of sound requires a baffle depth of quarter wavelength, so a perfect system of baffles to function down to 40 cycles would require a cabinet some 7' in depth.

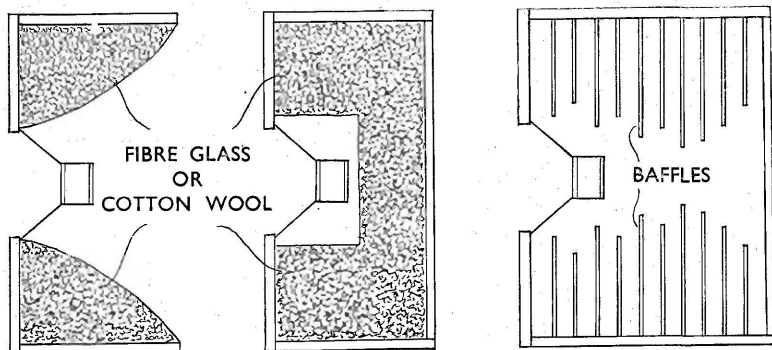

FIG. 9/9.—Various Cabinets with acoustic absorption.

If you accept the plea that the function of good L.F. response is to couple the largest possible mass of air to the cone, you will reject the system. If, on the other hand, you object strongly to any trace of air-column or horn resonance, you may welcome an absorption system with open arms—or open ears. In class-rooms with strong reverberation effects, the method may be very successful. In fact, lively rooms with hard, bare walls often favour the use of enclosed speakers, thus limiting the sound to a single source and reducing confusion.

FOLDED TAPERED PIPE

An interesting application of this principle is to be found in a new speaker recently introduced by Decca.

The design is based on Voigt's patent and has been developed by Mr. West, as already outlined on Page 35. It is well known that a pipe closed at one end develops third and fifth harmonics. In this case, the speaker is mounted one-third of the way from the closed end of the pipe in order to kill the third harmonic. The pipe is folded in two to give a reasonable size, and is placed with the speaker facing the corner of the room so that sound is reflected from the walls to improve high note diffusion. Fitted with an 8" unit of special design with open die-cast chassis, this speaker system reproduces down to 40 c.p.s. with remarkable efficiency, as there is large acoustic output from the open end of the pipe, which is dispersed by reflection from the floor.

CHAPTER 2

EXPONENTIAL HORNS AND MULTI-SPEAKERS

Constructional details are now given of an adaptation of the Ambassador design which was illustrated in "Loudspeakers". Several readers have expressed a desire to take advantage of the efficiency of horn loading, which can be usefully applied to domestic conditions by adopting a corner position. Another advantage of exponential horn design is that all dimensions may be altered in proportion; this affects the frequency range without upsetting the principle of loading.

The horn in question was designed for use with a 12" bass speaker with a cone resonance around 35 c.p.s. It would be advisable not to use a unit with cone resonance above 50 cycles, in order to avoid undue coloration in reproduction. The design could easily be adapted to suit a 15" speaker by increasing all dimensions by 20 or 25 per cent—the bigger the better.

A reduction in size to suit a smaller speaker would probably result in a deficiency of extreme L.F. response.

Details of the treble flare are not given as dimensions are not critical. The reader will use his own discretion as to method to be adopted, whether flare, open baffle, corner reflection, ribbon, etc.

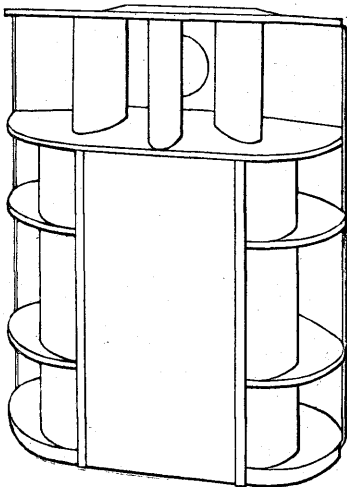

FIG. 9/11.

Full view of treble and
bass horns, $41\frac{1}{2}$ " high.

Courtesy
R. N. Fitton Ltd.

BASS HORN.

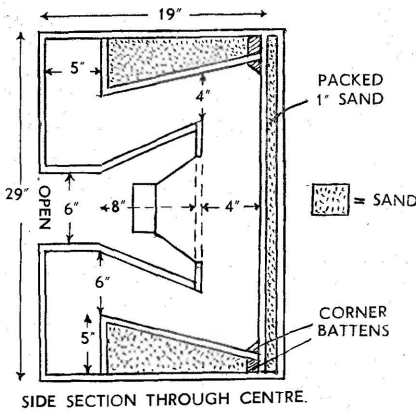
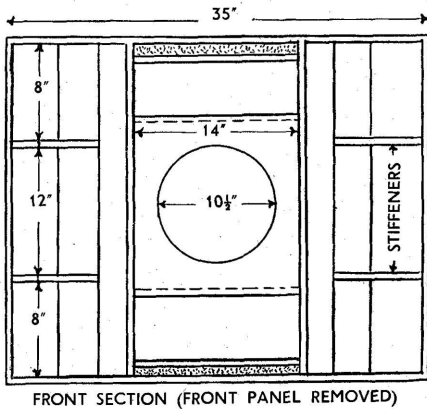
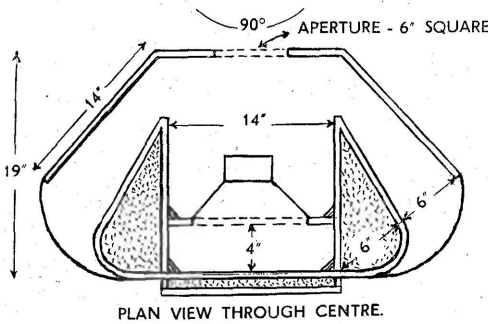

FIG. 9/12.—Bass Horn
(Ambassador Radio).

It will be observed that the sound waves from the front of the cone are first directed upwards and downwards, and then sideways to emerge parallel with the walls of the room.



MULTIPLE SPEAKERS

We all know that there are more ways of killing a cat than by choking it with cream. There appear to be about as many different ways of mounting and using loudspeakers. Some may be as extravagant as the above method of feline extermination.

The general idea behind the use of multiple speaker installations is to achieve a sort of "chorus" effect from several cones in the treble, and to improve low frequency output by increasing the area of radiation, and using the gain from reflecting planes between the various closely mounted cones.

One practical advantage is that the power is divided between a number of speakers, and therefore trouble-free working over a long period could reasonably be expected. If a slight fault developed in one of the units it would probably not be noticed.

Improved results from a number of inexpensive speakers do not imply that it is possible to change geese into swans by multiplication, but rather that shortcomings are obscured by working each unit at low volume, thus to a certain extent avoiding frequency doubling and intermodulation distortion. The main objection to such speakers is the fact that the cone resonance is high.

The writer has already demonstrated in his booklet "Loudspeakers" (pp. 48 and 49) how the bass resonances in speaker units are appreciably reduced by using two speakers of quite different cone resonance in parallel. It follows, therefore, that cleaner bass can be obtained from units of moderate size and price by using a number of speakers with suitably staggered resonances. It is claimed in some quarters that good results are possible by grouping a large number of units of the same size without widely varying resonances; but it is logical to assume that staggering at, say, 70 and 50 cycles would be better than bunching resonances around 60 c.p.s. The truth of this assumption is confirmed by the impedance curves which appear later in this chapter.

In order to test the multiple speaker idea from the angle of the domestic user, a battery of nine similar 8" units was mounted on a $\frac{3}{4}$ " plywood baffle 36" x 32" with 8" sides. At the outset, it is most important to make sure that the speakers are all in phase. Each unit should be tested with a small dry battery and marked according to which way the cone jumps. Speakers connected in pairs should then be tested by applying the battery impulse to the input to the pair. When all the speakers are connected up, the shock should be applied to the main input leads, and each cone should be watched to make sure that all the cones move in the same direction. These precautions are necessary because one speaker out of phase will upset the L.F. performance of the entire system. It should hardly be necessary to add that the flashlamp battery must not be reversed during the tests.

In order to maintain a convenient load impedance, the 15 ohm speakers were mounted in pairs in series (30 ohms), and the pairs were then connected in parallel, with one odd single unit. The total impedance came out at about 9 ohms.

The set-up was tested, but results were boomy and resonant, with a distinct peak in the region of 60-70 cycles—the average cone resonance of the individual performers. It may be possible to subdue this effect by using 18 or 36 units: I did not try, because it strikes me as too clumsy a solution for domestic use.

Applying fibre-glass or cottonwool absorbent pads to front and/or rear of the assembly reduced the resonance, but also removed much of the life from the performance. A plain resistance of 3-4 ohms across one pair of speakers removed a good deal of boom and gave pleasant results at medium volume, but introduced serious distortion at 5 to 10 watts.

Results were improved by fitting a special H.F. unit with isolating condenser, and replacing two bass units by 10" cloth surround speakers with cone resonance at 45 cycles. The two speakers were isolated from treble by a series inductance. (See Fig. 9/13.)

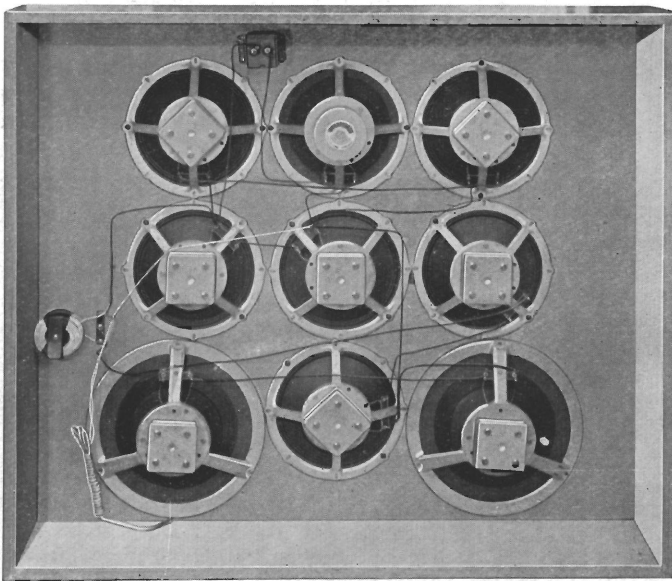
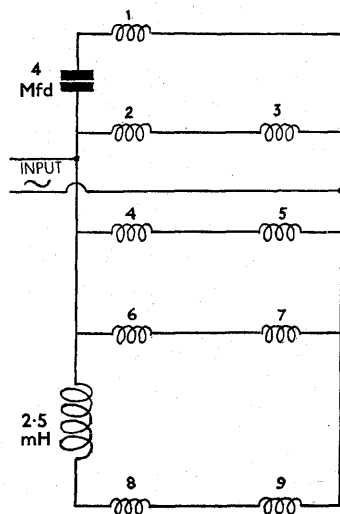

FIG. 9/13.—Rear view of multi-speaker assembly.

EXPONENTIAL HORNS AND MULTI-SPEAKERS

It is worth noting here that, although the input to the H.F. unit was attenuated at 3 db per octave from about 4,000 cycles downward, the cone vibrated visibly when fairly large input at 50 cycles was fed to the other speakers. This was the result of air and mechanical transmission, and goes to show how absurd it is to mount treble units in the same enclosure or in the immediate vicinity of L.F. radiators, thus undermining the effectiveness of the crossover network.

The following circuit diagram shows the correct wiring for uniform phasing, provided each unit is magnetised in the same way and the coil windings are in the same direction.



No. 1.—8" Treble unit, 15 ohms, cloth surround. Magnet 13,000 lines.

Nos. 2-7.—Six 8" units, 15 ohms. Treble and Bass. Magnets 10,000 lines. Resonance 60-70. ~

Nos. 8-9.—Two 10" units, 15 ohms, cloth surround. Bass only. Magnets 10,000 lines. Resonance 45-55. ~

FIG. 9/14.—Circuit diagram of multi-speaker system described in text.

It is difficult to improve on an impedance curve for giving a picture of what happens in various speaker systems. The next diagram shows the beneficial effect of changing the two bass units and staggering the resonances. It is also clear that the impedance characteristic of a battery of speakers is superior to one unit of similar quality mounted in a similar way.

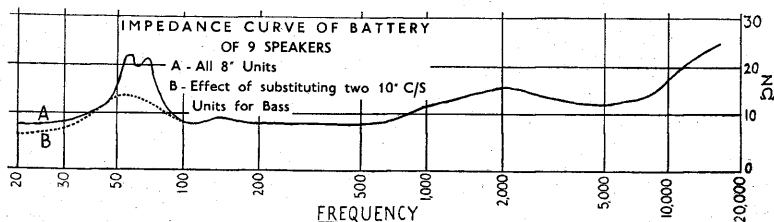

FIG. 9/15.—Impedance curves of multi-speaker system described in text.

It was found possible to reproduce 30 cycles at low power without frequency doubling (checked by harmonic analysis of output), in spite of the fact that this frequency is about an octave below the average cone resonance of the radiating source. The general quality of reproduction was not free from cabinet resonance. Something much more rigid than $\frac{3}{4}$ " plywood mounting would be required to overcome this trouble at volume levels which should be within the capacity of the equipment.

How shall we assess the performance of the system in absolute terms? It is hardly possible to do so. It was actually compared with the brick assembly and open treble, described in Chapter 8, and various people were invited to listen and express opinions. It was curious to note that audio engineers and experienced listeners voted unhesitatingly for the brick affair, but the average listener at first preferred the multi-speaker reproduction, changing to the other after 10 or 15 minutes of demonstration. My own opinion is that the best reproduction of bass is still obtained by really low cone resonance with some form of adequate, non-resonant coupling to the air, and the most natural treble is achieved by open mounting.

CHAPTER 3

DENSITY AND VIBRATION

When considering the most suitable material for the construction of cabinets or baffles, the density or specific gravity of the medium offers a very useful guide. The tone of reproduction is also slightly affected by the viscosity, velocity and Young's modulus of the material. An attempt was made to classify results according to these three qualities, but was abandoned as futile. It suffices to say that hard materials tend to give a bright tone and reduce hangover in comparison with wood, and are favoured by the writer. If the tone is too hard it may be softened by lining with Celotex or other building board. A combination of different materials in cabinet structure is worth consideration to avoid tonal monotony.

All will agree on the necessity of overcoming vibration and resonance at low frequencies, and this is achieved by adequate density. The following DENSITY LIST is included for purposes of comparison and choice :—

DENSITY OF MATERIALS in grams per cu. centimetre					
WOODS, ETC.		PLASTICS, ETC.		METALS & ALLOYS	
Ash	·64	Cellulose Acetate	1·3	Aluminium ..	2·7
Beech	·65	Paper	1·0	Cadmium ..	8·6
Celotex	·32	Shellac	1·7	Cobalt ..	8·7
Cork ..	·25	CERAMICS		Copper ..	8·6
Mahogany	·67	Brick	1·8	Gold	19·3
Maple	·68	Concrete ..	2·6	Iron	7·8
Oak	·72	Glass	2·4	Mazak (Cast) ..	6·0
Pine	·45	Granite ..	2·7	Lead	11·3
Plywood	·67	Marble	2·6	Nickel	6·8
Walnut	·56	Porcelain ..	2·4	Silver	10·6
Weyroc	·81	Dry Sand ..	1·5	Steel	7·7
		Slate	2·9	Tin	7·3
		Tiles	2·0	Tungsten ..	19·0
				Zinc	7·1

It will be noticed that oak is the heaviest of the timbers and $\frac{3}{4}$ " solid oak would be equal to 1" solid walnut.

The higher density of Cellulose or Shellac justifies spraying or polishing the interior of a cabinet or the inside surface of a wooden horn.

In order to make a practical test, a completely non-resonant brick enclosure was constructed, and various units from 8" up to 15" were tested, with astonishing results—crisper bass, cleaner transients, and improved reproduction in general. The indications are that the effect of cabinet resonance has been under-estimated in the past.

VIBRATION TESTS

A complete set of tests of various cabinets and materials was then made, using a vibration pick-up, and an output level of $\frac{1}{2}$ watt from oscillator. The acoustic output of the speakers varied according to their efficiency, with the usual peaks at resonance points. As these effects occur in normal use, no attempt was made to control or subdue them. The density figures show the actual density per sq. cm. of the material in the thickness used.

It is estimated that vibrations at a velocity below the level of $\cdot 01''$ per second may be considered to represent a non-resonant or satisfactory condition. Details of tests now follow :—

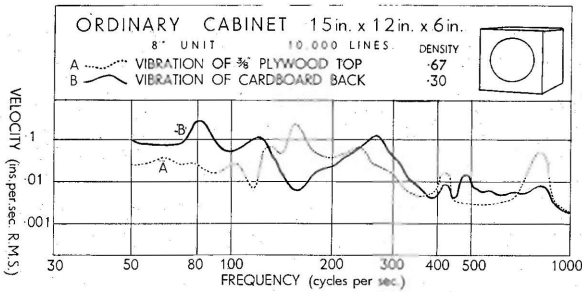

FIG. 10.—Small cabinet ; vibration of top and back.

In this case, the effect of the cardboard back was not so objectionable as usual due, probably, to the fact that the resonance peaks do not coincide.

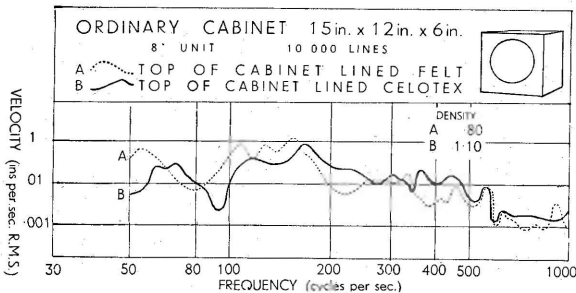

FIG. 11.—Effect of lining cabinet top. (Compare with Fig. 10.)

Note that the Celotex lining lowers the vibration below 180 cycles, whereas the Felt has more effect above this frequency. The small effect of lining is due to the restricted area involved, which is only $15'' \times 6''$.

DENSITY AND VIBRATION

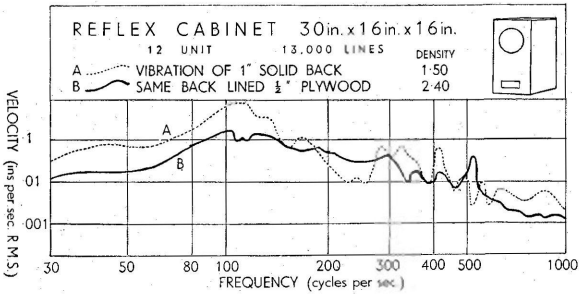

FIG. 12.—Vibration of solid back.

The vibration level is high as a result of larger area and more efficient unit than previous tests. The extra rigidity with plywood lining resulted in improved reproduction of both speech and music. Vibration readings on front and side of cabinet were only slightly less than back.

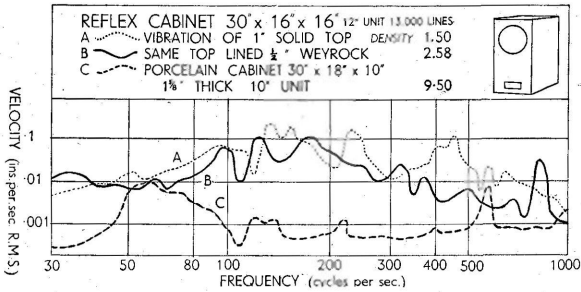

FIG. 13.—Vibration of wood and porcelain.

Curves A and B show the effect of lining a 1" solid wood top with 1/2" Weyroc. (Weyroc is a very hard board made from compressed shavings and sawdust.)

Curve C is in the nature of an experiment, the cabinet being actually a converted kitchen sink. The high density is reflected in the low level of vibration. Reproduction was very clean and bright but the tone was perhaps a trifle "cold".

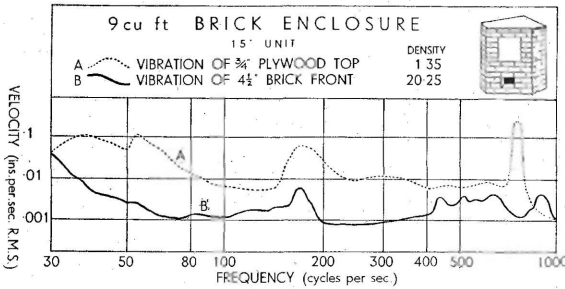

FIG. 14.—Brick structure with plywood top.

These readings are probably the most interesting of the series. The characteristics of the brick front are practically perfect, with a rise in the extreme bass towards the cone resonance which, in this case, was at 20 cycles. The plywood top reveals vibration at the air column resonance of 55/60 cycles, with a further rise at 165/180 cycles. As a Reflex chamber behaves like a pipe closed at one end, the first overtone is at third harmonic, which in this case is 165/180 cycles. The sudden peak at 700 cycles appears to be a peculiarity of most forms of plywood. As the top of this Reflex system represents less than one-sixth of the surface area, these vibration resonances are not of sufficient extent to mar the reproduction, but a cabinet of similar dimensions constructed of $\frac{3}{4}$ " plywood throughout revealed very strong resonance, and could not be used without considerable reinforcement.

SUMMARY OF VIBRATION TESTS

1. The worst effects of vibration appear to be confined to the region below 200 cycles.
2. Large panels, acoustic chambers, increase of volume and improved low frequency response all intensify vibration and call for greater rigidity.
3. Non-resonant cabinet structures improve transient response and help to remove coloration from speech and music.
4. Lining with felt absorbs high frequencies and reduces vibration mainly in the 600 to 1000 cycles region, without improving structural rigidity to any great extent.
5. Lining with Plywood, Weyroc, Celotex, Lead, Beaver Board or any similar material improves rigidity and reduces resonance. Cross-stays, sand-filling between surfaces, and many other methods may be employed.

MINIMUM DENSITY

The following list is an estimate of minimum area density for non-resonant condition in various speaker systems, together with possible materials for achieving it.

Speaker	Cabinet Volume (cubic feet)	Peak Input Watts	Sug- gested Density	Alternative Materials and Minimum Thickness		
				Plywood	Oak	Concrete
8"	2	5	1.5	$\frac{7}{8}$ "	$\frac{3}{4}$ "	$\frac{1}{4}$ "
10"	4	10	2.5	$1\frac{3}{8}$ "	$1\frac{1}{4}$ "	$\frac{3}{8}$ "
12"	6	15	3.0	$1\frac{3}{4}$ "	$1\frac{1}{2}$ "	$\frac{1}{2}$ "
15"	9	20	4.0	$2\frac{1}{4}$ "	2"	$\frac{5}{8}$ "

FIG. 15.—Minimum Densities for non-resonant Cabinet

The required thickness of any materials may be worked out by reference to the Density List, p. 29. For example, a density figure of 3 is attained by 4 centimetres or 1.57" of Plywood. A conversion table for centimetres and other measures is given at the end of the book.

CHAPTER 4

CABINET LINING

Questions are often asked about the advisability of lining speaker enclosures with felt or other sound-absorbing material. This is quite distinct from the use of a rigid lining for reducing panel resonance, although it is found that Celotex or similar wallboard can sometimes be used for both purposes.

It should be remembered that the object of loudspeaker mounting is to pass on the sound waves from the cone to the listening room with maximum efficiency. The fitting of sound absorbents to such a system appears, therefore, to be an uneconomical step, which should only be undertaken where necessary.

The answer to the question seems to depend on the following conditions :

1. Frequency range involved.
2. Structure of enclosure.
3. Listening room.
4. Taste of listener.

1. It is clear that resonance and standing wave effects are set up in a cabinet enclosure where the dimensions are comparable to the wavelength. (See chapter on air-loading.) We also know from the early days of the gramophone that resonances in the middle and upper-middle register are most objectionable. It is therefore advisable to subdue such resonances by absorption where they are likely to occur. For instance, the wavelength at 500 c.p.s. is about 2', so there would be slight resonance at this frequency and its harmonics in a cabinet 24" high, which could be reduced by absorbent lining. On the other hand, large enclosures lower the frequency of such resonances, thus reducing the need for soft lining, and incidentally improving the quality of reproduction. Another point is that felt and similar materials possess a higher coefficient of absorption at frequencies above 300 cycles than below, so the use of a crossover network reduces the need for felt lining in the bass enclosure. Where a single unit is used for the full frequency range, the case for soft lining of the enclosure seems to be well made out. Ordinary corrugated cardboard is quite a useful lining for breaking up a reflecting surface.

2 & 3. The tone of reproduction is affected by the structure of the enclosure, as well as by the furnishings of the listening room. For instance, a marble or brick corner arrangement for bass gives a bright

tone which may suit a thickly carpeted room, but may require "softening" with Celotex or felt lining in a room without carpets or curtains.

4. As regards the listener's taste, there is not much to be said. Felt lining, by absorbing high frequencies more than low frequencies, appears to improve bass response and cut the "top", and gives a warm, round tone, compared with a more brittle tone from hard surfaces. Fortunately, a test can be made without undue expense, as the cheapest quality of thick felt is suitable. In fact, one could purloin a couple of square yards from underneath the carpet, but it might be advisable first to pack the wife off to the pictures, and so put off the day of reckoning until the next bout of spring cleaning breaks out.

AMERICAN VIEW

The following is an extract from a letter received from Mr. Peter DeVere of Los Angeles :

"We all admit that music and its reproduction and appreciation are entirely subjective and cannot be judged objectively or by analysis on instruments. Now, it is my own particular hobby-horse to insist that the number one factor which can make or break a performance is Reverberation. Famous musicians who are interested in recording improvements, such as Mr. André Kostelanetz, Mr. Morton Gould and my very good friend Dr. Leopold Stokowski, will inevitably come out with a reverberationally live recording. This leads me to my most glaring disagreement with part of your books, for I do *not* want a reproducer that will add nothing to the input. Thus, I would not think of using absorbent materials or a brick enclosure. I use a heavy, totally enclosed 8 cu.ft. cabinet for bass, and an open-back 10 cu.ft. cabinet made of *thin* plywood for treble."

I have selected these observations from a long and extremely interesting letter to support the view that the listener's taste enters into the question ; in fact, it might almost be said to dominate it when Mr. DeVere really gets going. I would like to point out one thing, and that is that a brick (or similar) reflex enclosure does not cut out all reverberation, especially when not lined with felt. There is a good deal of local colour below 60 cycles with a suitable speaker, which I think helps to add life to the reproduction, without being objectionable on speech. So far as the middle and upper-middle registers are concerned, it is my particular hobby-horse to insist that reverberation in cabinets will break any performance of either speech or music, and remedial measures are justified. The effect of lining with felt is clearly shown in the Chapter on Air-loading, page 59.

REVERBERATION

Mr. DeVere insists on the necessity for a really "live" performance for good results and mentions the Symphony Hall in Boston as one of the finest halls in America, claiming that reverberation compensates for a slight lack in acoustical bass response. By comparison, he finds European recordings generally more "plushy" in inherent acoustical tone. In demanding adequate reverberation, I do not think Mr. DeVere will meet with much opposition from critical listeners over here. It is only necessary to hear a piano recital in Wigmore Hall, London (surely one of the finest in the world for piano tone), and then hear a similar instrument in a theatre, to appreciate the stifling and deadening effect of excessive absorption. I believe that a good upright piano would sound better in Wigmore Hall than a fine concert grand in the average theatre. On the other hand, any ensemble bigger than a quintet is overpowering in Wigmore Hall and wind instruments tend to become piercing in tone.

The problem is to achieve the correct amount of reverberation to suit the programme, and is one which receives a lot of attention from broadcasting and recording authorities. The object of these remarks is to point out that the reverberation goes in with the performance and it should not be necessary to add to it in reproduction by using cabinets made of thin plywood, nor should it be necessary to fether the response with festoons of felt.

FLARES AND HORNS

It is hardly necessary to repeat that the inside surface of a horn should be as smooth and hard as possible, so that the minimum of obstruction is imposed on the sound waves. The same remarks apply to the tapered pipe described in Chapter I. The constantly varying width of the pipe avoids the setting up of resonances and standing waves to the same extent as occurs in cabinets of uniform width; in fact, any form of absorbent lining in such systems is wrong and would be detrimental to results.

CHAPTER 5

AIR LOADING

The effects of air loading on the performance of loudspeakers are so varied and complex that the subject merits a chapter to itself, in spite of the fact that this may mean covering some ground which has already been traversed in other chapters. As a matter of fact, the views expressed in this chapter formed the basis of a lecture-demonstration given by the writer to the British Sound Recording Association in London on 25th November 1949.

To deal first with low frequencies, the importance of air loading is already widely appreciated, yet true bass reproduction is in general quite as inconspicuous by its absence as true "top". The idea that the ear replaces the missing low tones is of course a fallacy. A certain impression of low notes is created, but this impression by no means forms a true picture, because the missing fundamentals are not re-created with their original power, and anything which upsets the balance of power in the harmonics of a musical tone *ipso facto* upsets its quality or character.

This question of power in harmonics is one of the most important elements of true reproduction. If you use a loudspeaker with a cone resonance at 120 cycles, the resonance colours not only the tones around that frequency but also the first overtone of 60 cycle notes and the second overtone of 40 cycle notes. To this must be added all the ill effects of frequency doubling over a range of about two octaves. Very low cone resonance therefore not only gives us good bass response, but also avoids the distressing effects just described.

The balance of power in overtones is also seriously affected by air-loading of loudspeakers at higher frequencies, particularly in the region of 1,000 to 5,000 cycles where the wavelengths are between 12" and 3" and are therefore comparable to dimensions met with in small cabinets or horns.

The essentials of true reproduction of bass could be summarised under four headings :

1. Full response down to 30 c.p.s.
2. Absence of frequency doubling.
3. No pronounced resonance.
4. Adequate diffusion to give effect of spaciousness.

Let us examine these essentials in turn.

1. The easiest approach to full response down to 30 cycles is by means of a large cone with long voice coil working in a deep magnetic gap to maintain the magnetic field cut by the coil. It is worth noting that these requirements are the direct opposite of the best coil and-gap arrangements for high note efficiency. A short coil in a shallow gap improves H.F. efficiency but leads to thin bass of rough quality. (See Fig. 15/1.)

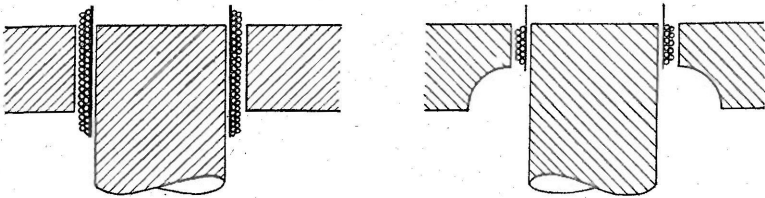

A. Long coil for smooth L.F. performance.

B. Short coil in shallow gap for maximum H.F. performance.

FIG. 15/1.

With a given magnet, the design B increases the flux density per sq. cm. without increasing the total flux; the short coil is light in weight and will not move out of the gap when the input is limited to the higher frequencies. On the other hand, design A maintains maximum total flux, and any loss of efficiency due to the long coil is amply justified by smooth response at comparatively large amplitudes of movement.

2. **FREQUENCY DOUBLING.** This is an interesting fault. Actually, generation of third and fourth harmonics often occurs, which is really frequency trebling and quadrupling. To coin a phrase, frequency troubling would be a better name. It is quite a common effect in musical instruments and is difficult to avoid in some cases, as you quickly discover if you try to play one of the lowest notes of a clarinet without the necessary skill. The influence of air loading on the fault is dealt with in Chapter 7.

3. **RESONANCE.** Adequately covered in other chapters.

4. **SPACIOUSNESS.** This is an essential element of natural reproduction, especially in the bass, and is one reason why large reflex cavities and large flares sound better than small ones. No doubt fame and fortune await the genius who succeeds in giving us large scale results in small compass, especially if accompanied by attractive design and appearance. It is unfortunate that the eye and the ear so rarely agree on what is best.

There are at least ten systems for trying to achieve adequate L.F. performance through the coupling of the loudspeaker to the room. These may be listed as follows :

1. Exponential Horn.
2. Large Baffle.
3. True Infinite Baffle (Wall).
4. Open back Cabinet.
5. Reflex Cabinet (Vented Enclosure).
6. Acoustic Labyrinth.
7. Cabinet with acoustic absorption.
8. Totally enclosed Cabinet.
9. Tapered Horn.
10. Multiple Speakers.

It would be difficult to say which system is the best. Good results are possible in different ways, provided the fundamentals already outlined are observed. Unfortunately, any device which is good for the low frequencies is unhealthy for high frequencies and therefore unhealthy for the overtones of the low notes.

There is no perfect method of coupling the performance of a 70-piece orchestra to a room of domestic size, as there will always exist the differences which are inherent in the different listening conditions. Your choice as to which is the best depends largely on what you listen *for*, and on the time you have spent in trying to overcome certain faults. If you have made a study of delayed response characteristics, you will choose a speaker with good transient response, even if it entails a method of mounting which imparts a touch of boxiness to the reproduction. If you spend much time in taking response curves and working for wide response, you will select as best the model with the widest response. If you have devoted much time to open-mounting to avoid cabinet and horn coloration, you will reject any system which suffers from these defects, and so on. We are, of course, here referring to experts, and by experts we mean men who dissipate time and money in investigation.

Broadly speaking, the object of air loading on a cone is to increase the mass of air which is set in motion and thus improve the acoustic output. There is general agreement when this is well done in the extreme bass. The middle and upper registers are the stumbling block, as the method of housing the speaker colours the reproduction. Why? Perhaps the simplest explanation is to look at the organ pipe for our analogy :

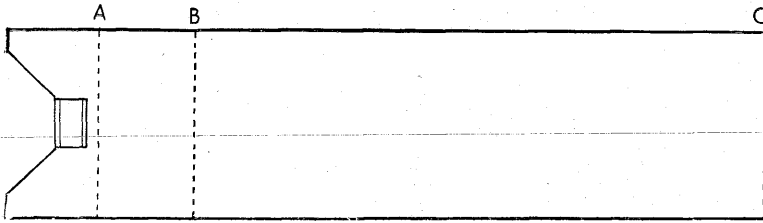

FIG. 15/2.—Organ pipe of varying lengths A, B and C, with speaker unit mounted in one end.

We know that an open pipe of 8' length gives a note around C at 64 c.p.s., and a closed pipe of 4' plays a similar note; also that an open 4' pipe plays an octave higher than an open 8' pipe. If you chop off most of the pipe shown in the diagram and leave only 8" or so as at A in Fig. 15/2, you arrive at a common-or-garden cabinet (radio variety), but in principle you still have an organ pipe of high pitch but poor efficiency. If you chop off at B in the drawing, you arrive at a deep-sided cabinet, the pipe frequency is lower than A and more pronounced, which results in the boom so well known with deep-sided cabinets. If you continue the pipe 3' or 4' to position C, you have what is known as an Acoustic Labyrinth, the frequency is much lower than pipe B, and your low frequency output is boosted. You have, of course, also improved L.F. response by increasing the path length between front and back of cone. A reflex cabinet is similar to the acoustic labyrinth but the shape is different. A loudspeaker is a very powerful source of sound and determines the frequencies produced in the pipe, but there can be no doubt that the results are coloured by the characteristics of the pipe, even when we consider only fundamental tones.

The overtones and higher frequencies are also seriously affected by the shape and dimensions of the pipe or cabinet. If we accept the organ pipe analogy as outlined above, we must also accept the analogy of other musical instruments in which the tone colour is determined by the shape and material involved. For instance, conical shape produces even harmonics, and the flare shapes of cornets and saxophones have much to do with their respective brightness and "sugariness" of tone.

Somewhat similar results occur with air-loading of the human voice or the loudspeaker cone. This is easily tested by speaking into pipes or flares of different shape, such as the following :

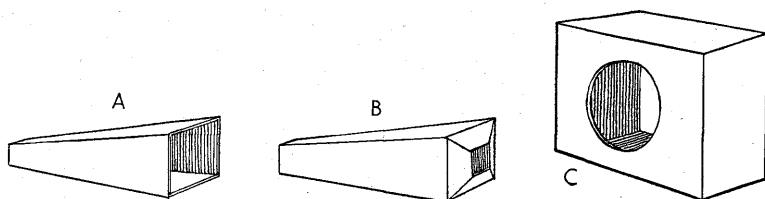

FIG. 15/3.

In each case the tone of the voice is affected by the design of the pipe, the narrowing outlet of design B cutting the higher overtones more than the tapered horn A. Even design C, which is a typical loudspeaker cabinet, has considerable effect on the voice, and serves to prove that mutilation of overtones occurs when one side of a cone vibrates into a similar cavity. The inference is that 99 per cent of the radio sets and radiograms in use today introduce unnatural coloration into speech and music. The obvious remedy is to remove the overtones and higher frequencies from the box and adopt open mounting. It is quite easy to make a rough and ready test. Simply place an extra speaker on top of your set or radiogram, without any baffle, and connect it up in parallel and in phase with the existing speaker, and observe the improved "top" and clarity which will undoubtedly ensue if the extra speaker is reasonably good. If in doubt, allow a few days for the ear to become accustomed to the fresh quality of sound. Results may be still better with a crossover network, because the crucial overtones are then completely removed from the cabinet. This seems to provide a much stronger reason for using two speakers and a separator than the usual argument for avoiding intermodulation; it also militates against the use of expensive single speakers or even coaxial types where the air loading adopted for good bass response has to be imposed on the upper register willy-nilly.

For frequencies of 1 kc, a path length of 6" is all that is required to avoid cancellation between front and back waves, so quite a small baffle suffices with the usual 1,000 cycles crossover, and it is absurd to use too large a size. Quite a light plywood baffle is satisfactory for the treble unit; there is no fear of resonance when the low frequencies are absent.

INTERNAL RESONANCE

In order to find out what is happening under certain conditions, it is often useful to exaggerate those conditions for the purpose of test, especially where accurate measurements are not required. A cabinet was therefore made in the form of a cube with 12" internal diameter, to arrive at a wavelength around 1,000 c.p.s.

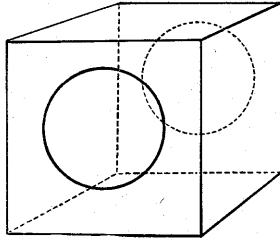

FIG. 15/4.—Box for acoustic test, cube shape. 12" internal diameter.

An 8" aperture was made in two opposite ends of the box, as shown in sketch, and a 10" speaker with cloth surround was mounted facing into the box so that the enclosure could do its worst to the sound waves before they emerged through the opposite end, into the sound-proof room.

The test turned out to be one of those rare acoustical events (rare at least in the experience of the writer) where results confirmed almost all theoretical expectations, and endorsed the opinion expressed earlier in this chapter that the most serious effects occur where the wavelength is comparable to the dimensions of the cabinet.

The following curves give a fairly good picture of what happens. The first represents the response of the 10" unit on infinite baffle—not a bad speaker as 10" units go—whereas the second curve shows the response after the sound has passed through the box.

A general inspection of the second curve reveals the fact that the most violent fluctuations occur between 1,000 and 4,000 cycles where the ear is very sensitive to tone colour, the dips from cancellation effects of standing waves being more pronounced than the resonant peaks. A more detailed inspection leads to the following interesting deductions :

1. The Snowdonian peak at 200 cycles is the general cabinet resonance. Compared with Dr. Olson's curves in Fig. 5 on page 23, the frequency of 200 cycles would be about right for the dimensions involved.
2. The peak at about 700 c.p.s. is probably due to the diagonal dimensions of the cabinet, combined with the third harmonic of the general cabinet resonance. There is a fourth harmonic peak at 2,800 cycles. The other harmonics appear to have been affected by those of the main resonance.

AIR LOADING

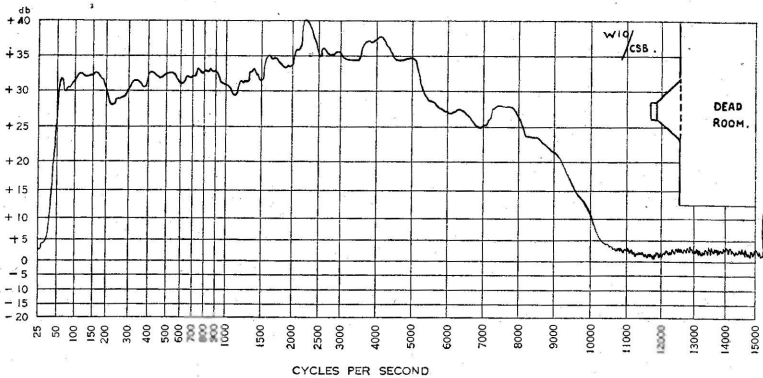

FIG. 15/5.—Response curve of W10/CSB speaker. 1.4 volts at 400 c.p.s.
Infinite baffle.

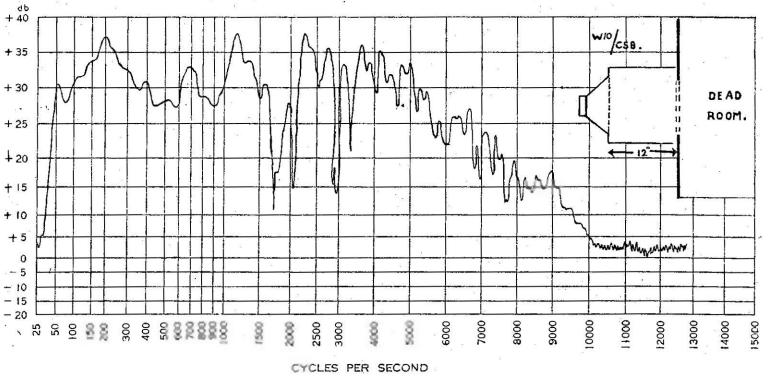

FIG. 15/6.—Response of W10/CSB speaker working through 12" cube, and infinite baffle. 1.4 volts at 400 c.p.s.

3. The main internal dimensions of 12" would give a calculated resonance at 1,120 cycles, which is clearly shown in the highest peak in the curve. Second and third harmonics are also clearly discernible at 2,240 and 3,360 cycles.
4. There are two very big dips in response between the peaks at 1,120 and 2,240 cycles, which are repeated between 2,240 and 3,360 cycles. The general pattern is then repeated several times up to the point of cut-off.

There can be no doubt that the method of mounting a loudspeaker affects the upper middle register as well as the bass and calls for special consideration.

FELT LINING

The next step was to line the cube with felt and take a response curve under exactly the same conditions as before, thus revealing the effect of the absorbent lining on the output from the box, Fig. 15/7.

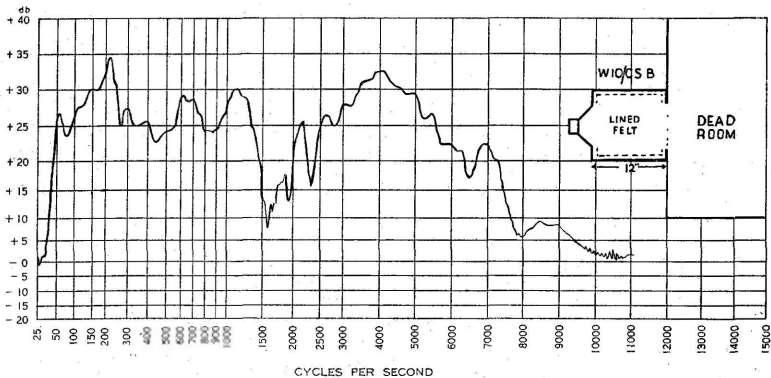

FIG. 15/7.—Response of W10/CSB speaker working through felt-lined 12" cube. 1.4 volts at 400 c.p.s.

The results are interesting. The cabinet/speaker resonance has gone up from 200 to 220 cycles due to slight reduction of internal dimensions, with third and fifth harmonics at 660 and 1,100 cycles now clearly marked. This confirms the opinion that the system operates like a pipe closed at one end, in which the odd harmonics are normally produced. The diameter resonance is tacked on to the fifth harmonic mentioned above. Cancellation effects between 1,200 and 2,500 cycles still occur, but the output above this region is remarkably smooth as a result of the absorption characteristics of the felt.

I should like to acknowledge here the valuable assistance of Hawley Products Ltd. of Tottenham in the above series of tests; their recently installed sound-measuring equipment is of a very high order, and has been used for these investigations.

It is not suggested that tone colour in reproduction is a new problem. Paul Jennings recently referred to it in the *Sunday Observer* in his usual diverting manner, as the following extract shows:

ODDLY ENOUGH

by Paul Jennings

Soon after I was born
People were paying hundreds of gns.
For primitive wireless sets, which emitted various squeaky dins
Through an Exponential Horn.
(This, I should explain
To those who, like myself, in the science of Electronics couldn't
be dopier,
Was a kind of metal cornucopia
Through which our ancestors in amazement heard
The Nightingale and Hullo Twins and Jack Payne.)
It was so tinny
That they only listened because it was fashionable to do so
And, since it made even Caruso
Appear to *whinny*,
They approached it in much the same way
As Dr. Johnson did the woman preacher, when he said
(I am quoting this out of my head)
"Sir, it is like a dog walking on its hind legs. One does not say
'It is not done well' —
One
Is too surprised to find it done
At all." (It's amazing how often he rings the bell.)
Thus, people were not so tireless
In listening to the radio when it was still called wireless
Until some wretch cried "Eureka!
I have invented the Moving Coil Loudspeaker."
And, wreathed in smiles,
Proceeded to demonstrate that it was audible for *miles*.

(Courtesy *Sunday Observer*)

RESPONSE CURVES

The following curves are in a way associated with air loading, and are reproduced in order to emphasise the fact that response curves should be used for purposes of comparison rather than as measurements of performance. The curves all relate to the same 8" speaker unit and were taken by three different firms—each equipped with expensive apparatus for the work.

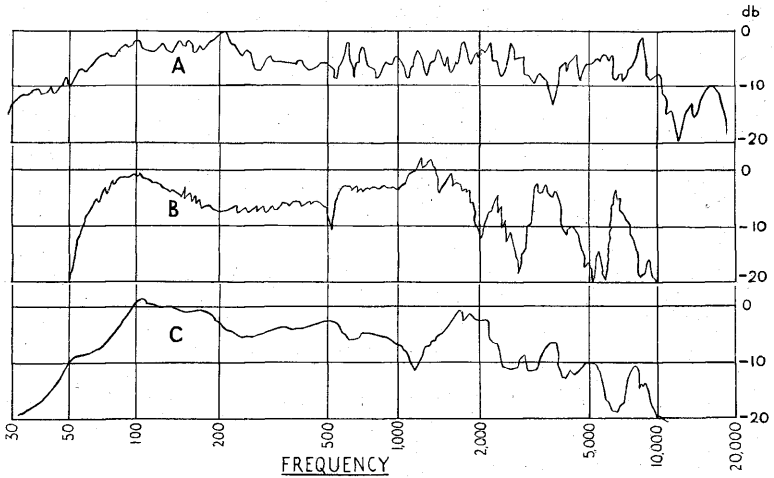

FIG. 15/8.—Response curves of same 8" speaker taken under different conditions.

In spite of their common origin, it is difficult to trace any blood relationship between these curves; at best one would say that they might be related by marriage.

The enormous variations are due to air-loading and reflection effects—not to faulty equipment. It is therefore necessary to have some knowledge of the inherent characteristics of the conditions of measurement before attempting to interpret response curves in terms of perfect reproduction. The main value of such curves is in comparing results from the same equipment.

CHAPTER 6

FREQUENCY RANGE

The difference of opinion on this question appears to be as great as ever, although it is to-day widely agreed that the mere extension of the frequency range does not alone ensure lifelike reproduction. There are many other factors involved. The B.B.C. transmits a frequency range of 30 to 10,000 c/s on a first-class programme when transmitted on medium wave. On long wave transmission the range of frequencies covered is reduced in the upper register to an upper limit of the order of 8,000 c/s. Where, however, programmes are taken over long land lines, there is, naturally, some reduction of the higher frequencies. Still, the quality of the B.B.C. Scottish Orchestra, as received and transmitted in England, is found to be excellent, in spite of restricted frequency range from land lines. It may be admitted that a modern gramophone record goes up to 14,000 cycles or more, and that a light-weight pick-up of good design will reproduce the full range, yet most people would agree that the live broadcast gives the better quality.

AMERICAN VIEWPOINT

Let us see what the New World has to say about it. There was an interesting article on High Fidelity by Mr. Marvin Camras, of Illinois Institute of Technology, which appeared in the July, 1948, issue of

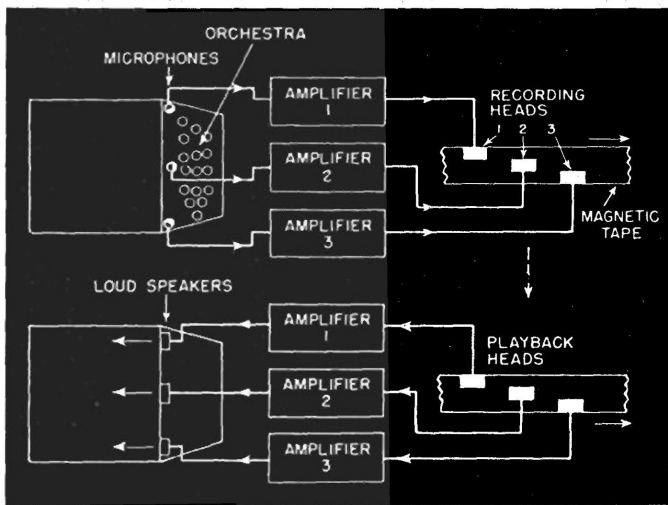

Reproduced by courtesy of Tele-Tech, N.Y.—Marvin Camras.

FIG. 16.—Diagram of 3-channel stereophonic recording and playback circuits.

“Tele-Tech”. The author suggested that a 5,000 cycle binaural system may be preferable to a monaural system flat to 15 Kc/s.

Details were given of a magnetic recorder built for experiments with stereophonic sound. Specification: Frequency response 30 to 10,000 cycles \pm 5 db. Noise level 60 db below signal. Max. distortion 4% intermodulation or 1% harmonic.

The system used is illustrated in Fig. 16 and Fig. 17.

Sound is picked up by 3 spaced microphones, recorded on separate channels, and played back through 3 spaced speakers.

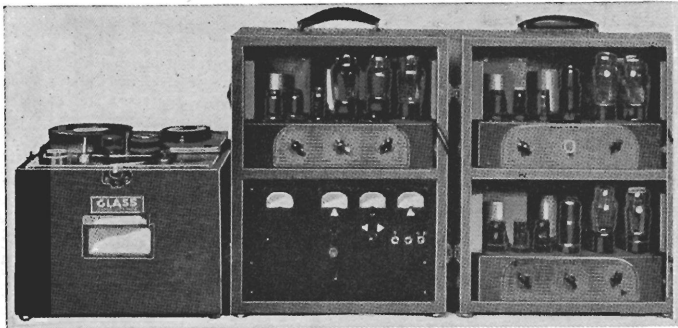

[Reproduced from *Tele-Tech*, July/48—Marvin Camras.

FIG. 17.—Magnetic recorder with 3 amplifiers for stereophonic reproduction of sound.

Mr. Camras concludes his article by saying that on playback the effect is not of sound coming from any particular speaker but from points in space somewhere between the speakers. Choirs and symphony orchestra give the illusion of actual presence in the room.

LIVE PERFORMANCES

Tests to ascertain the reactions of listeners to restricted frequency range applied to live performance of music are described in the second edition of Olson's "Elements of Acoustical Engineering". The schematic diagram is reproduced in Fig. 18.

The acoustical filter consisted of three sheets of perforated metal which could be rotated in sections to introduce severe attenuation of frequencies above 5,000 cycles. The changes from wide open to low pass were made every 30 seconds, and the results indicated a preference for the full frequency range. Similar tests on speech reported a distinct lack of presence with the limited frequency range.

FREQUENCY RANGE

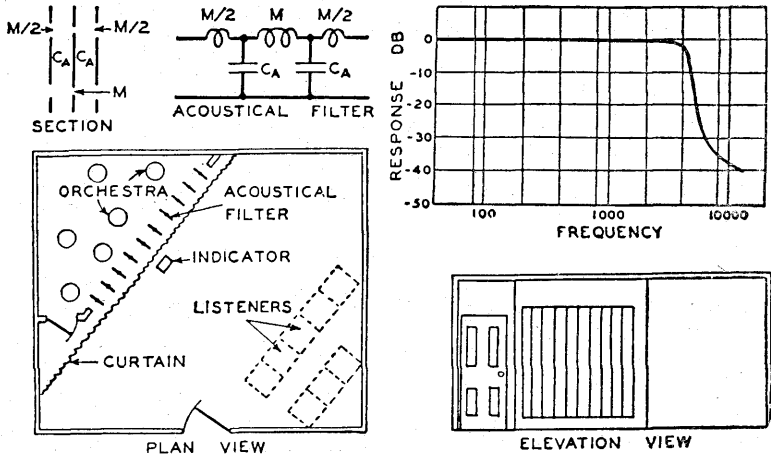

From Olson's "Elements of Acoustical Engineering"

FIG. 18.—Plan and elevation views of the schematic arrangement of the apparatus for direct frequency preference testing of speech and music. A sectional view, acoustical network and response frequency characteristic of the acoustical filter used in the tests are also depicted.

REPRODUCTIONS

Unfortunately, similar tests (after Chinn & Eisenberg) with *reproduced* speech and music showed a majority in favour of medium or narrow frequency ranges compared with wide range or so-called high-fidelity reproduction. The conclusion is that the distortions and deviations from true reproduction of the original sound which still occur are less objectionable with a restricted high-frequency range.

VERY HIGH FREQUENCIES

If we examine the few instruments which produce the very high tones, say from 12,000 cycles upwards, we find they possess all or nearly all of the following characteristics:—

1. Metal construction, with high Young's Modulus.
2. Percussion operation with metallic source.
3. Indefinite or random pitch, especially immediately after striking.

The triangle is made of steel and is tapped with a steel rod. Steel has a high rate of Young's Modulus, 19×10^{11} , hence the brilliance. If tapped with wood the brightest overtones are lost because the wooden striker does not rebound so quickly as the steel one, and therefore damps the vibrations of the triangle. Young's Modulus of wood is about 1.2×10^{11} .

Cymbals are made of brass, which has Y.M. 9.5×10^{11} , and the high-pitched sizzling of the snare drum is caused by a steel wire brush.

No attempt is made to tune these high frequencies. They are allowed to blend with the music in any key. It is, therefore, not unreasonable to say that full scale reproduction of such percussion sounds is not absolutely essential to the musical appreciation of orchestral performances.

In view of the above, it will be clear that other musical instruments such as wood-wind and strings do not contain the characteristics required for producing the highest overtones, and even a percussion instrument like the piano would need steel hammers for the purpose. We can, therefore, reproduce ordinary instruments quite well without response at 12 Kc/s and upwards, apart from associated noises which may be better subdued.¹

Other sounds with very high frequencies are hand-clapping, key-jingling and similar random noises, all again percussive and of indefinite pitch. An interesting point is that the fundamental of a half-penny balanced at its centre is about 12 Kc/s, and the main overtones can be heard quite readily.

HIGH PITCH REPRODUCTION

In order to reproduce sounds of very high pitch with all their true brilliance, it would be an advantage to use a medium with similar characteristics and to keep the mass as low as possible. Young's Modulus of paper is 4.8×10^{10} and Phenolic Resins are about 8.0×10^{10} ; so paper impregnated with such resins would not normally respond fully to the highest frequencies. The H.F. range can, however, be extended by the use of very fine material of this type, and extremely high flux density can be used to overcome the natural limitations of such diaphragms.

METAL DIAPHRAGMS

Aluminium or Duralumin with Young's Modulus of 7.0×10^{11} suggest themselves as suitable media, the latter being the better of the two materials because of its superior elastic properties. Furthermore, the low density of these metals enables light yet rigid assemblies to be made. A ribbon-type speaker has been developed by E.M.I. which does, in fact, reproduce key-jingling with remarkable fidelity.

¹ It is appreciated that summation tones may involve very high frequencies even with instruments of this class, but it is not improbable that such summation tones are again produced by the sound waves leaving the loudspeaker. It would be an interesting test to find out to what extent frequencies above 10 kc/s are produced in the listening room by complex sounds passed through a reproducing chain with a cut off at 10 kc/s. The addition of recorded summation tones to similar tones produced in the listening room may account for the rather "tinny" character still associated with wide range reproduction of recorded music, and some limitation of very high frequencies during recording may eventually prove desirable.

FREQUENCY RANGE

A third speaker or special diaphragm for very high frequencies about 12 Kc/s and upwards would therefore appear to be justified on technical grounds.

The advantages to the domestic user would be restricted by the following considerations:—

1. Radio transmissions usually have an upper limit of 10,000 c.p.s., often reduced to 5,000 cycles by necessary selectivity in tuning.
2. Permissible H.F. response from commercial records is limited by distortion factor and surface noise.

RESONANCES

The avoidance of "peakiness" becomes difficult when viscosity is very low, as with duralumin. The effect of viscosity in a vibrating system is analogous to that of resistance in a tuned circuit, namely, to determine the degree of damping and, therefore, the sharpness and range of the resonance.

The following typical resonance curves for (1) dural, (2) resin-impregnated paper, and (3) untreated paper have been computed by Mr. F. W. James.

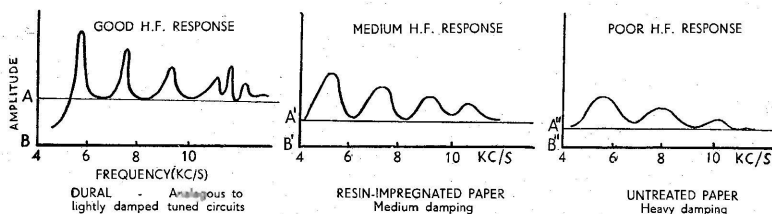

FIG. 18A

General level of amplitudes $AB > A'B' > A''B''$.

N.B.—The sign $>$ means "greater than".

In view of the peakiness of low viscosity material such as duralumin in the frequency range of 4,000 to 10,000 c.p.s., it is advisable to limit the response in this region by using a very small diaphragm and, if necessary, a crossover network, otherwise the general tone of reproduction will be unpleasant.

The foregoing remarks on frequency response should not be interpreted too literally. They do not mean that if you fit a tin cone and coil assembly to any magnet you will have response up to 20 Kc/s; nor do they mean that your speaker is dumb above 12 Kc/s if it is

not furnished with aluminium trimmings. What they do mean is that, with the same flux density and mass, low viscosity material has a better response at very high frequencies than material with high viscosity.

TRUE BASS

During recent years, efforts to widen the range of reproduction have mainly been directed upwards, and high fidelity is commonly understood to refer to high frequency response. The extreme bass is equally important, and delving down is likely to lead to less trouble than climbing too high. Modern equipment certainly goes down to 30 cycles, yet how many loudspeakers are there in use to-day which will reproduce this frequency without generating harmonics?

It is true that few musical instruments produce a fundamental tone as low as 30 cycles. The lowest in the orchestra is the double bassoon at 33 cycles, but there are difference tones at higher frequencies, and the true reproduction of these difference tones requires a speaker which will go down to the lowest frequency passed by the rest of the equipment. The presence of these low tones adds greatly to the smoothness of reproduction and broadens the general outline, and the absence of frequency doubling removes the knocking effect which is common to the majority of the speaker systems still in use.

Really clean bass reproduction, once heard, makes a lasting impression on the ear, and is further considered in the next two chapters.

SUMMARY

There can be no objection to wide range equipment in principle, as it is so very easy to apply the tone control to the extreme top when necessary, with the possible exception of pick-ups with strong resonances at very high frequencies which may produce spurious difference tones at lower frequencies which would remain in spite of tone control.

ORCHESTRAL INSTRUMENTS

The following diagram gives a very clear picture of the fundamental tones covered by the main instruments of an orchestra, (Fig. 18B).

Although the various shapes do not typify the relative power output of each instrument or group of instruments, the diagram is useful in estimating where the maximum volume is located. This is clearly in the frequency range of 100 to 1,000 cycles. There are only difference tones below 40 cycles and the power must be small in this region. Above 1,000 c.p.s. there are 8 instruments with appreciable response, plus overtones from practically all the others. When two speakers with crossover at 1,000 cycles are used, it is found that units of equal sensitivity give good balance. Assuming full orchestral output of 5 watts from amplifier and allowing for lower sensitivity of hearing

FREQUENCY RANGE

PRINCIPAL ORCHESTRAL INSTRUMENTS.
RANGE OF FUNDAMENTALS.

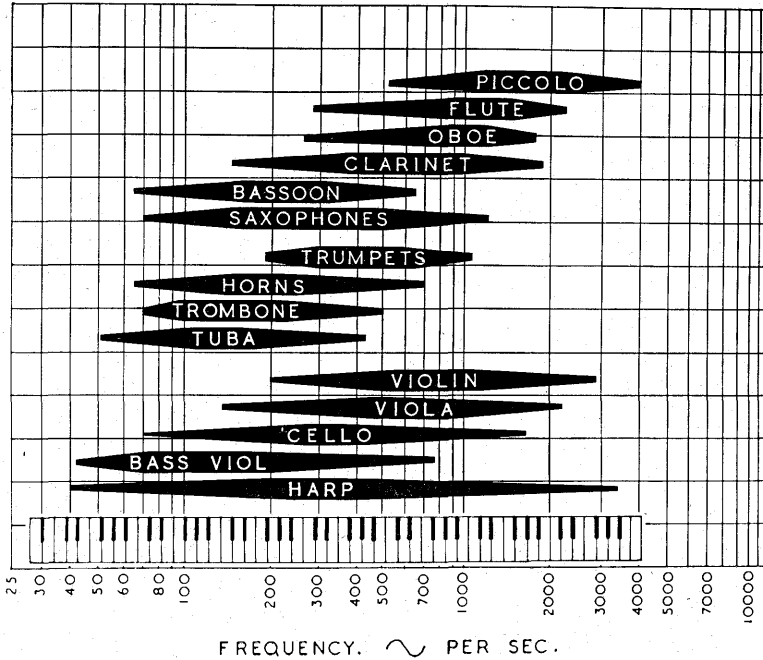

FIG. 18B.

G. E. Watts

below 1,000 cycles, it is estimated that the power is divided at 3 watts to bass unit and 2 watts to treble unit, approximately. The balance between the two speakers will vary continually according to the music, but there is not much danger of overloading the treble unit in such cases.

PSYCHOLOGICAL EFFECTS

As regards listening in general, there is a psychological side to the question. Some people find that strong H.F. response has a stimulating effect, whereas others find it irritating. Many prefer the more soothing influence of rather mellow tone. One reason for these varying reactions may be that more time is occupied in listening to reproduced music than in attending live performances.

*Sooth'd with the sound, the King grew vain;
Fought all his battles o'er again.*

JOHN DRYDEN.

CHAPTER 7

ANALYSIS OF SOUND, AND FREQUENCY DOUBLING

Harmonic analysis of sound has been used in the science of acoustics for many years but it is only recently that instruments for this purpose have been produced commercially. With the help of an audio-frequency analyser it is possible to throw a good deal of light on the performance of loudspeakers, even under conditions where absolute accuracy may not be ensured. After all, we—the listeners—are mainly concerned with what we hear and how we can improve results according to our own standards of good quality. On this basis the following tests have been conducted.

MALE VOICE

Estimates of the frequency range covered by the average male voice usually state 100 cycles upwards, yet speaker resonance in the 80/100 cycle range results in strong coloration of the majority of men's voices. A test of the writer's voice saying, "One, two, three, four" fairly loudly revealed the following :—

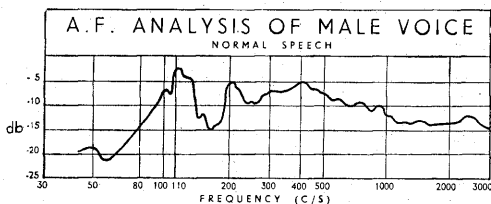

FIG. 19.—Step by step analysis of voice saying "one, two, three, four" at a volume level of 70 db into microphone.

With the type of analyser used, separate readings have to be taken at different frequencies, so it is impossible to show the complete spectrum, and considerable time is involved in noting the main peaks and dips in the sound. The analysis serves to show that there is a good deal of energy in the voice below 100 cycles, and steps to keep resonance in loudspeakers below 80 cycles are necessary to avoid unpleasant effects.

FREQUENCY DOUBLING

This is one of the commonest forms of distortion in loudspeakers. The following tests were made to expose and measure the actual nature and extent of the fault. It will be observed that frequency doubling is hardly a correct description of the trouble, as in some

cases there is only frequency trebling, and in others there is generation of second, third, and even fourth harmonics. Fundamental frequencies of 30, 40 and 50 cycles were tried, as well as cone resonance frequencies, and although tests were made at higher input levels all curves are shown at $\frac{1}{2}$ watt from oscillator to maintain a uniform basis for comparison. This may seem a low level of input, but it was essential to have a pure note from oscillator, and it should be remembered that at 30 or 40 cycles there are few fundamental tones from an orchestra, and we are mainly concerned with difference tones of low power. One more point. Most of the tests were made in a room¹ about 17 ft. square with walls and ceiling covered in Beaver Board. The results are therefore affected by reflection, but similar conditions apply to all tests. An open-air check on one speaker was made to ensure that the faults actually occur under free-field conditions.

The total output level is given in each case, but as this includes the harmonics it should not be taken as a true indication of efficiency.

A selection from the numerous tests made now follows.

HARMONIC ANALYSIS OF SPEAKER OUTPUT WITH SINGLE TONE INPUT AT VARIOUS FREQUENCIES

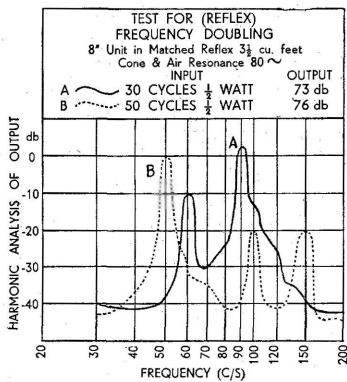

FIG. 20.

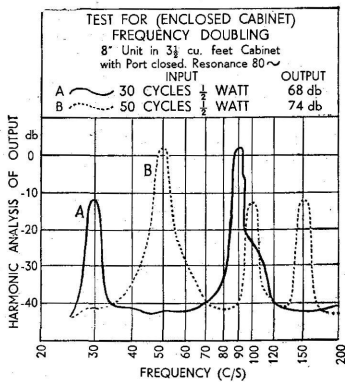

FIG. 21.

The first two diagrams, 20 and 21, illustrate tests with a Reflex cabinet fitted with matched unit. Curve 20A shows that the system will not reproduce 30 cycles, but is quite good at 50 cycles, 20B. Fig. 21 is the same speaker with the port closed for infinite baffle effect. This improves the 30 cycle state, but increases harmonics at 50 cycles.

Not very helpful, apart from proving that such a system cannot do justice to 30 c.p.s.

(¹) As the wavelength at 30 cycles is 37½ feet, a room more than 18½ ft. long would theoretically be required for full reproduction, although in the present tests a corner position was actually used.

ANALYSIS OF SOUND, AND FREQUENCY DOUBLING

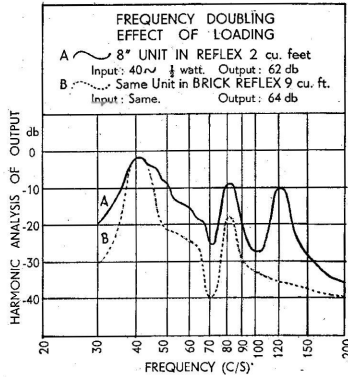

FIG. 22.

This shows the improved wave form at 40 cycles with same unit mounted—

A—In small Reflex cabinet 30" × 15" × 8".

B—In brick corner Reflex of 9 cu. ft.

The importance of air loading is clearly demonstrated here.

In the case of 22B closing the port had little or no effect, so the 8" unit had reached infinite baffle conditions.

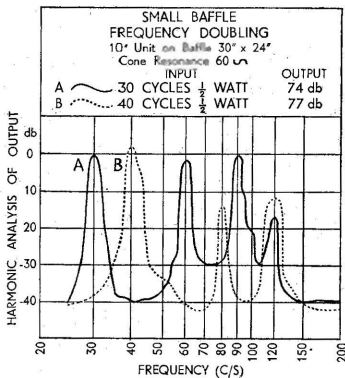

FIG. 23.

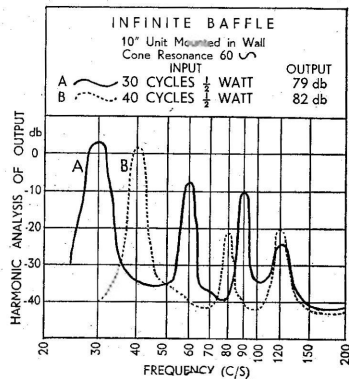

FIG. 24.

The diagrams 23 and 24 relate to a 10" unit with cone resonance at 60 cycles mounted first on small baffle and then on a true infinite

ANALYSIS OF SOUND, AND FREQUENCY DOUBLING

baffle. Putting 30 cycles into a speaker with a 60 cycle cone resonance is rather like hitting below the belt, but even so the infinite baffle shows lower harmonic content than the small one. At 40 cycles the result is fairly good.

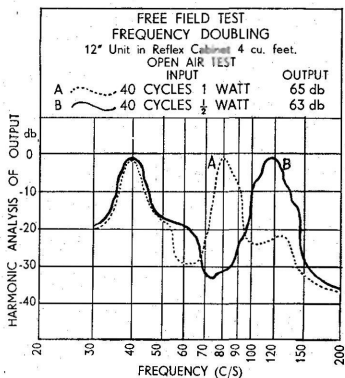

FIG. 25.—Analysis test taken outside, at 40 cycles. Cabinet 30" × 16" × 16".

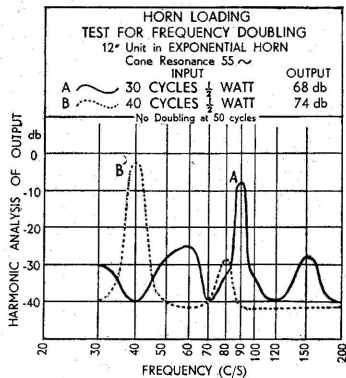

FIG. 26.—Flare 5' 8" long, Mouth 4' square. Material 16 gauge steel.

Test 25 shows the actual free-field result, with doubling at 1 watt and trebling at $\frac{1}{2}$ watt. This size of cabinet appears to be rather small for the 12" unit. Much cleaner bass was given in larger cavity, infinite baffle or large horn.

Test 26 was taken in a storeroom about 40 ft. long, with a 12" unit mounted in a large exponential horn with a nominal cut off commencing at 140 cycles.

The system would not take 30 cycles, but the result is extremely clean at 40 cycles, showing that a well-designed horn gives good loading to a cone at frequencies below nominal cut-off.

The curves in Fig. 27 show the effect of $\frac{1}{2}$ -watt input at the frequency of cone resonance.

Curve A, 12" unit in 30" × 16" × 16" Reflex shows rather serious doubling at 84 cycles.

NOTE: The output levels stated in FIGURES 20 to 28 should only be used for comparing one result with another in this series. The levels indicated cannot be interpreted as absolute db above threshold of hearing.

ANALYSIS OF SOUND, AND FREQUENCY DOUBLING

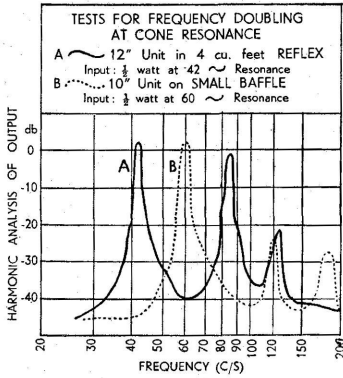

FIG. 27.

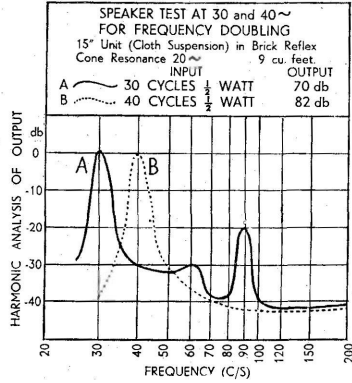

FIG. 28.

Curve B, 10" unit on small baffle. This takes 60 cycles much better than 30. See 23A.

Fig. 28. As expected, the 15" units show the cleanest results.¹ Equally good analysis was obtained with wall mounting, and also with 15" speaker with corrugated cone. There can be no doubt about the improved bass to be had from large cones.

In all cases, normal listening tests showed the best quality of bass from the speakers with the cleanest analysis.

SUMMARY OF TESTS

1. The peaks and dips in the curves should not be taken as representing absolute sound level. They should be used for comparing one result with another. It was found that different samples of the same model of A.F. Analyser gave the same peaks but different degrees of attenuation between the peaks. It is, therefore, necessary to state that -40 db or -35 db might just as well read -30db, and the writer could not say which figures would be correct.
 2. The volume of air loading on back of cone plays a big part in the quality of very low tones. Inadequate loading intensifies generation of harmonics.
 3. Reflex cabinets with matched cone and air resonance still suffer from frequency doubling with inputs at a lower pitch than resonance.
 4. Air column resonances do not appear to generate pronounced harmonics.
- (1) The slight rise in curve 28/A at 60 cycles and the peak at 90 are probably due to air column resonance which in this case occurs around 60 cycles.

5. Cloth suspension does not overcome frequency doubling at points below the cone resonance, but it does help to lower the frequency at which the trouble may begin.
6. Corrugated cones will withstand a larger increase of power, without excessive doubling, than equivalent types with cloth suspension.
7. The tests have been rather severe and the speakers should not be condemned as a result. The deliberate intention was to expose trouble.

In "Loudspeakers" (2nd and 3rd Editions, page 80) it was stated that an 8 inch unit in matched Reflex Cabinet went down to 40 cycles without frequency doubling. The actual meaning was "without audible doubling," because A.F. analysis sometimes reveals harmonic content which is not detected by the ear. It is a question of degree, as in other forms of distortion, and absolute perfection may be an ideal beyond normal attainment. Figures 20 to 28 should therefore be interpreted in practical terms as follows :

HARMONIC PEAKS		AUDIBLE RESULT
Higher than Fundamental		Hopeless
Equal to	"	"Knocking" sound.
10 db below	"	Clean, but plays two octaves
15 " "	"	Acceptable.
20 " "	"	Very good.

8. The frequency accuracy of the Analyser is beyond question. The writer was able to locate any note of a piano within half a semitone by use of the instrument.
9. Increase of power naturally intensifies any distortion. With 40 cycles at 1 watt the 8" units were very rough. The harmonic content of 10" and 12" units was increased by approximately 6 db and 3 db respectively compared with $\frac{1}{2}$ watt. 15" units were still below the -30 db level.
Large power at 30-40 cycles will only be encountered with organ music. The Compton Organ Co. in their Electrone organ, use 40 watts output with a 12" unit for treble and an 18" unit for bass. The volume is ample for a large church, and the lowest note produced is 32 cycles. Tested in a fairly big canteen, the low notes rattled the windows. Only a small part of such power is required for a small room, and a 15" unit should easily suffice.
10. **NEGATIVE FEEDBACK** reduces loudspeaker resonance by cancelling part of the voltage rise. It follows that any frequency doubling caused by such resonance will be reduced by the feedback circuit.

CHAPTER 8

15 INCH SPEAKERS

After hearing many wide-range speaker systems in America, the writer has come to the conclusion that even at domestic volume levels a 15" unit is ideal as a low note reproducer. It is, of course, necessary to have a separate speaker for treble. The low resonance of the large cone simplifies the problem of producing notes as low as 30 cycles without frequency doubling, and housing in a suitable Reflex chamber brings air column resonance down to below 60 cycles, where speech is not affected.

The following diagram appeared in the second edition of the Loudspeaker Booklet mentioned in the Preface, and is repeated here along with a few hints for those who may consider installing a similar system without recourse to actual brick-laying.

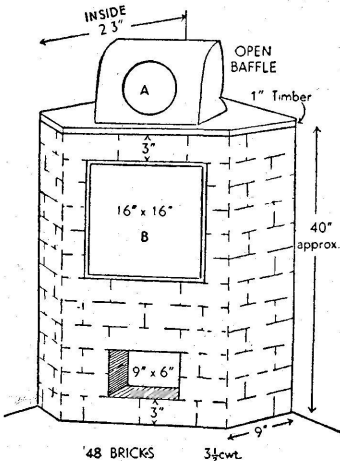

FIG. 30. — Non-resonant corner Reflex for bass. Capacity 9 cu. ft. Small open baffle reflecting into corner for treble.

In the original model, a 15" bass speaker with cloth suspension is used. The low note efficiency is so good that at 20 cycles the port emission blows out a lighted match with 2 watts into speaker. The actual quality of the wave form at 30 and 40 cycles is shown in the previous chapter. Other units, 12", 10" and 8" have been tested in the enclosure with remarkably good results compared with smaller and less rigid forms of mounting. (See Fig. 22B for effect on 8" unit.)

It is realised that many wives (one might almost say all wives) will raise objections to brick-laying activities in the lounge or drawing-room for the purpose of mere reproduction of sound, but there are many other ways of achieving the object. The writer has installed

15 INCH SPEAKERS

a marble panel in place of brick, with excellent results from both the feminine and acoustic point of view. The port is replaced by side openings which clear the skirting board and thus serve a double purpose, Fig. 31. The panel stands securely across the corner without being bolted to wall.

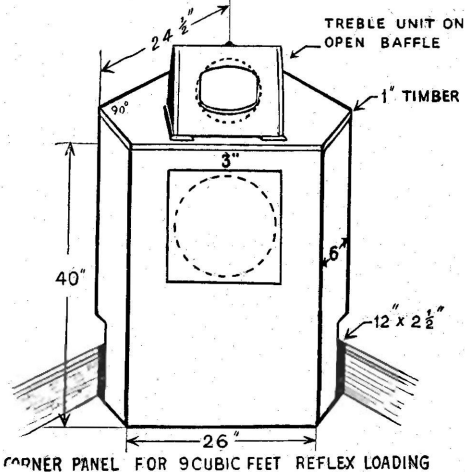

FIG. 31.—Diagram of panel to replace brick of Fig. 30.

The marble panel is $\frac{5}{8}$ " thick, or 1.6 cm. Reference to the Density List, page 29, shows the density of marble to be 2.6 per cu. cm., so a thickness of 1.6 cm. is equal to a density figure of 4.16. This means that a panel made of any material or combination of materials to give a density figure of about 4 would be satisfactory. In plywood this would require a thickness of 6 cm., about $2\frac{1}{4}$ ". A plywood panel half an inch thick and lined with half an inch of concrete or similar substance would serve admirably. The essentials for expected results are $\frac{8}{9}$ cubic feet in air volume, not less than 40" in height, and minimum density already outlined.

The top should be reasonably strong and should fit closely to the panel and the corner.

It is worth noting that the main advantage of the corner panel is the use of the corner walls for reflecting sound. Acoustically, the corner position is the best, but any arrangement which utilises existing walls to form part of the speaker system is most attractive. The walls are there and they are far more rigid than any specially made cabinet is likely to be, giving a combination of economy and efficiency.

The panel of Fig. 31 is but one method. Many other systems of corner reflection are possible with different sizes of speaker.

Smooth runs the water where the brook is deep.

King Henry VI, Part I, Act III, Sc. I

CHAPTER 9

DIRECTIONAL EFFECTS

Many listeners are distressed by the high-note beam which is produced by the normal direct radiator cone loudspeaker. I must admit that I am not personally seriously worried by this phenomenon. I find that tilting the treble speaker upwards so that the beam is directed towards the chandelier leaves the listener free to enjoy a reasonable off-axis H.F. radiation.

Another useful arrangement is to face the speaker to the corner of the room so that wide diffusion is obtained by reflection from the walls.

Placing a cone-shaped diffuser in front of the loudspeaker has often been tried, but there is the risk of cancellation effects at quarter wave lengths, and the resultant response at 30° off axis appears to be less smooth than the normal off-axis curve, according to tests we have made. Incidentally, expanded aluminium mesh, which is now widely used as speaker fret material, has no effect whatever on the loudspeaker response or diffusion.

A simple yet effective H.F. diffuser is the slot design patented by Kolster-Brandes Ltd. A demonstration with random noise, covering all frequencies up to 20 kc. proves that when the slot is vertical the speaker may be rotated quite 90° without noticeable difference to the high frequencies heard by the listener. On the other hand, with the slot placed horizontally there is a distinct increase in H.F. sound as the loudspeaker faces the listener.

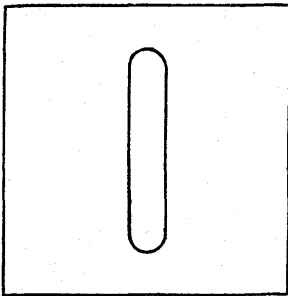

FIG. 31/1.—Slot Diffuser.

Courtesy Kolster-Brandes Ltd.

The length of the slot should be approximately the same as the piston diameter of the cone. The width should be determined in

DIRECTIONAL EFFECTS

accordance with the frequency range involved. Out-of-phase effects are avoided when the width of the slot is not less than the wavelength ; thus 1" wide will answer for frequencies up to 13,500 c.p.s.

There is a loss of power of the order of about 2 db with a slot of reasonable width. The device also has some effect on the loading of the cone at low frequencies. This should be borne in mind before fitting to specially designed bass chambers. It is of interest to note that the K.B. slot system was used in the loudspeaker installation at Radiolympia, 1949. Many people thought, not unnaturally, that the object of the slot was to direct the sound along the various gangways, whereas in point of fact the object was wide diffusion.

REFRACTING SOUND WAVES

There is an interesting article on this subject by Kock and Harvey in the September 1949 issue of the *Journal of the Acoustical Society of America*, which is recommended to those who are interested in the scientific aspect of the question. The paper describes a divergent lens in the form of a slant plate array. The plates are spaced $\frac{1}{2}$ " apart and are slanted at an angle of $48\cdot3^\circ$. The diffusing effect at the mouth of a horn 30" long with 6" square mouth is shown in the next diagram at frequencies of 4,000, 8,000 and 12,000 cycles.

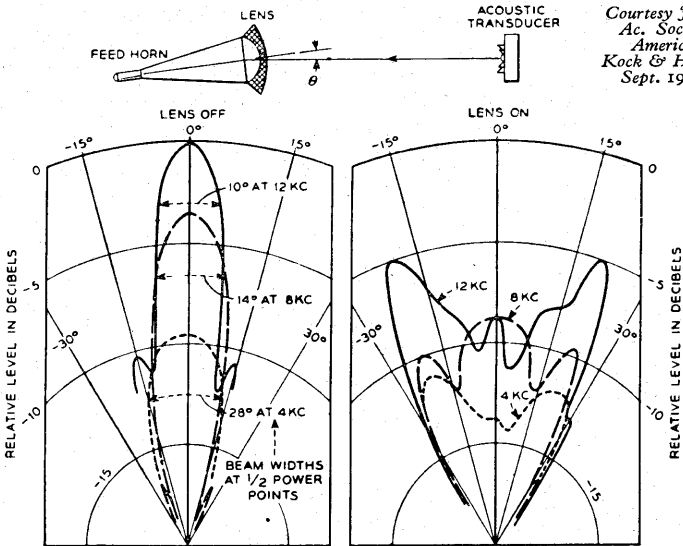

Courtesy *Journal of Ac. Soc. of America*, Kock & Harvey, Sept. 1949.

FIG. 31/2.—Horizontal plane directional patterns.

The plates should be made of thin material, such as sheet aluminium, to obtain maximum spacing effect with minimum obstruction. The next illustration shows the device in use with an ordinary loudspeaker. The area covered by the lens should be greater than the cone area, so that the sound waves must pass through the lens.

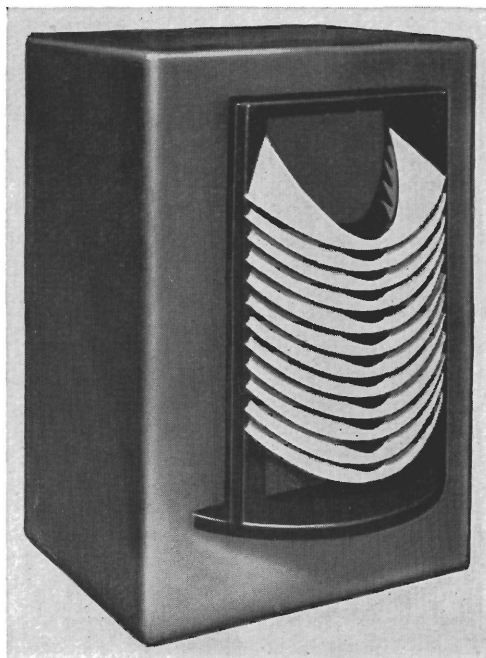

*Courtesy Journal of
Ac. Soc. of America,
Kock & Harvey.*

FIG. 31/3.—Divergent lens with conventional cone type loudspeaker.

With a speaker aperture 6" in diameter an array of twelve plates would be about right. The operating range is from 4 to 14 kc. The writer has made up a diffuser to this design, but is not sure of the correct width of the plates, so is unable to give a full report on results. It is a pity that so many of these technical articles, particularly in America, leave a small blank between the theoretical aspect and its practical application by the reader. Indeed, some scientific writers seem to take a fiendish delight in showing you the promised land, and withholding the means of transport.

CHAPTER 10

RIBBON SPEAKERS

It may be that, for some listeners, the best solution of the problem of good H.F. response at domestic volume levels will be found in the Ribbon, which possesses the inherent advantages of low mass and low impedance, coupled with a high rate of Young's Modulus.

The main disadvantage is the wide airgap necessary in the magnetic circuit to accommodate the ribbon. The wide gap requires an expensive magnetic system to maintain an adequate flux density. The ribbon is fragile, but if the amplitude of modulation is kept low by using high crossover frequencies of about 5,000 cycles the life of the ribbon can be quite satisfactory. Care must be taken, of course, in the preparation of the ribbon materials and its heat treatment. Corrugations are essential in order to eliminate local strains and to prevent local resonance.

Where the ribbon is used as a third speaker, a crossover at 5 or 6 kc. is just about right; a simple high-pass filter of about 4 mfd. in series with the special ribbon transformer protects the ribbon without upsetting the existing two-speaker crossover network.

If used in a two-speaker system, it would be desirable to arrange the crossover in the octave between 2,500 and 5,000 cycles, and to give due consideration to the air-loading of each unit.

At high frequencies, horn coloration does not appear to be so objectionable as in the middle or upper-middle registers, and is completely absent with the ribbon provided the horn cut-off is well below the crossover frequency. The mouth diameter should be greater than the wavelength of this frequency, say 6" for 4,000 cycles, in order to avoid impedance irregularities due to reflections at the mouth. Care must be taken to prevent the walls of the horn vibrating and giving rise to ringing. As regards the L.F. unit, it would be advisable to line the bass chamber with felt or similar material to reduce resonances and standing wave effects in the important region between 1,000 and 4,000 cycles.

The extremely low impedance of a ribbon unit is a point of considerable interest, as we have gradually become accustomed to the use of moving coil units in which the impedance rises steeply at high frequencies. In the opinion of the writer, full advantage has not yet been taken of the improved H.F. performance which is attainable by lowering the impedance of the treble voice coil in conventional two-speaker crossover systems. To test this theory, a 10" speaker with specially wound light-weight coil of 1 ohm was tried along with a 15" bass unit of 15 ohms impedance, with a crossover network which had

been designed for ribbon use. The transient response was very sharp, and results were considered to be much more akin to "ribbon" quality than reproduction from normally matched treble and bass units. It is therefore suggested that before handing the H.F. bouquet to the ribbon we might cut off a couple of blooms and present them to the very-low-impedance moving coil speaker. The use of an amplifier with negative feed-back or low impedance source is assumed.

The following illustration gives a picture of the ribbon speaker developed by E.M.I. Ltd., of Hayes, who were (so far as I know) the first to produce equipment embodying this type of reproducer. The photograph has been taken with the flare moved to one side in order to expose the ribbon to view :

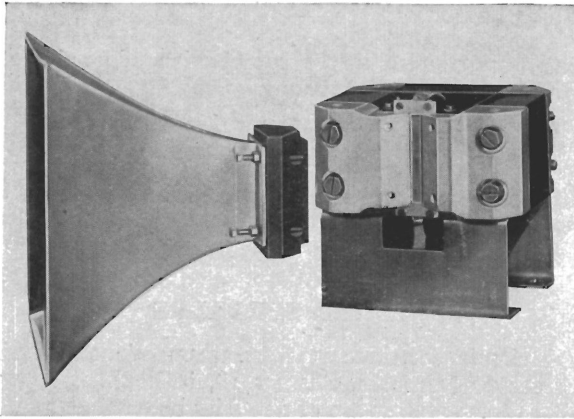

FIG. 31/4.—E.M.I. Ribbon Speaker.

The actual ribbon is $1\frac{3}{4}$ " long by $\frac{1}{4}$ " wide in aluminium less than one thousandth of an inch thick. The field strength across the gap is 5,000 gauss. A transformer with extremely low resistance windings is fitted. A ratio of about $8\frac{1}{2}$ to 1 gives a primary impedance of less than 0.75 ohm. The primary inductance is around 680 micro Henries, which means that the transformer will start to cut off at 5 kc and so help to protect the ribbon from overloading at lower frequencies.

There can be no doubt that the response is well maintained up to 20,000 c.p.s. This makes a difference to the tone of reproduction even to those who are not able to hear frequencies above 10 or 15 kc. It is also a change from listening to reproduction from cones, and a change is often considered to be as good as a rest.

RIBBON SPEAKERS

The following crossover network may not be the last word, but it works quite well with 15 ohms bass unit and a ribbon (with transformer). Crossover frequency 4,000 cycles.

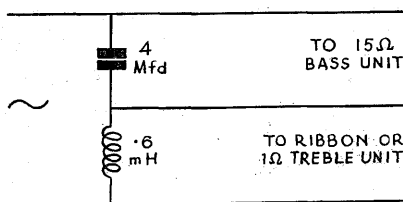

FIG 31/5.—Crossover circuit for two speakers of different impedance.

Listening tests confirm that a combination of good bass speaker and ribbon, with crossover at about 4 kc, gives excellent results and is not extravagant in materials and cost. At the same time, it is only fair to add that there are some recording and acoustic engineers who object to the "tone" of a ribbon speaker; it is clear that the problem of extreme high frequency response still remains to some extent a personal one.

THREE SPEAKERS

Although circuits for three speakers are mentioned in this chapter and in Crossover Networks, Chapter 18, it should not be taken for granted that three speakers are of necessity better than two. The fact is that on radio transmissions, the addition of a third speaker with improved response in the 10 to 20 kc range does not make much difference to a good two-speaker system, apart from intensifying valve hiss or other spurious H.F. sounds. On wide range gramophone reproduction, the effect is more noticeable, but here again surface noise may be more affected than quality of reproduction for two reasons :

1. The intensity of musical tones (or overtones) above 10 kc is very low, and
2. There are frequent passages of music in which the highest frequencies are absent.

As my own hearing cuts off at 13,500 cycles—I shall very soon be on the wrong side of 60—listening tests have been made by members of my staff who can hear distinctly up to 18 kc, to ensure that these reports are not influenced by senile decay. The general impression is that, with the sound sources at present available, the addition of a third

speaker is somewhat of a luxury. A greater impression can be made if the existing treble unit is replaced by one with lower flux density, giving poorer H.F. response and lower acoustic output in the upper-middle register, which is often over-emphasised in reproduction. The addition of the ribbon or third speaker may then give better over-all results.

CONE SPEAKERS WITH ALUMINIUM VOICE COIL

In some units, the voice coil is wound on an aluminium former, but the marked effect of using aluminium wire instead of the usual copper wire for the coil winding should not be ignored. This reduces the total coil weight by more than 50 per cent., and greatly improves the response at 10 kc and upwards without adding to the output in the upper-middle register. It also seems that the nature of the aluminium wire does something to the "tone" of reproduction which makes it more akin to ribbon quality than the normal copper drive-source. A comparison of the two substances is not without interest :

	Copper	Aluminium
Density gms./c.c.	8.6	2.7
Young's Modulus	11×10^{11}	7×10^{11}
Velocity of Sound in meters/second	3,560	5,100

The resistance of aluminium wire is about 50 per cent. higher than copper. Some disadvantages in use are as follows :

1. It is rather fragile, with a tensile strength much lower than copper.
2. It is difficult to tin and solder.
3. It is inferior to copper for bass reproduction, as the lighter weight raises the frequency of the fundamental cone resonance.

One advantage of an aluminium voice coil is an improved impedance characteristic. A normal 2 ohm speaker with copper winding rises to 8 or 10 ohms at 15 Kc., compared with a rise to 4.75 ohms with aluminium coil.

TRANSIENTS

When considering the performance of various materials as radiators of sound, we are apt to over-rate the importance of frequency response. The effect of aluminium and similar substances on transients may prove to be extremely important as the technique of measuring and tabulating results is improved.

CHAPTER 11

QUESTIONS AND ANSWERS

This chapter consists of a selection of questions raised by readers, with abbreviated answers, which are thought likely to be of general interest.

RESPONSE

Q. 1. Dr. J. W. J., Bradford

I have been using a 12" (corrugated cone) unit on 5' x 4' baffle for bass, with a 10" cloth suspension speaker on smaller baffle for treble. I find that if I reverse the order I get better bass from the 10" unit and more "top" from the 12". Does this mean that a corrugated edge gives better top response than cloth surround?

A. 1. Your 10" speaker must have a lower natural resonance than the 12" unit. As regards top response, many 12" speakers with powerful magnets are very strong in the region of 3,000 to 7,000 cycles, but fall off at higher frequencies due to mass of coil and cone. A corrugated edge often intensifies these resonances, but resonance should not be confused with response. We suggest you bring the speakers in for an oscillator test, but meanwhile use them in the way that sounds best. *Note.*—The speakers were actually brought in, and the bass resonance of the 10" unit was found to be 10 cycles lower than the larger speaker. It was also found that the top response of the 12" speaker was stronger than the 10" even at 10–14 kc. This, however, was due to the type of cone—not to the suspension. A cone with bakelised apex was fitted to the 10" unit, which brought the H.F. response higher than the 12" unit.

RESONANCE

Q. 2. N. S., S.E.5

The suspension of my 15" cloth surround speaker appears to be stiff. Do you think the stated resonance of 34 cycles is incorrect?

A. 2. No. The frequency of resonance depends on the weight of the cone and coil assembly as well as on tension. Increasing size and weight lowers the resonant frequency, so that robust construction and low resonance are quite compatible in large speakers.

SPEAKER MOUNTING

Q. 3. J. C., Gravesend

My speaker is mounted on a baffle with a base which stands on silent-block pads inside a radiogram cabinet. The front of the baffle and the metal fret are insulated by three layers of rubber and a wooden frame as shown in sketch. Treble and bass are satisfactory but there appears to be unnatural tone at middle frequencies. Is this due to the insulated mounting?

A. 3. The hollow sound is probably due to the fact that the speaker is mounted too far behind the face of the cabinet, leaving an air trap around the front of the cone. We had a similar effect when starting to use sand-filled panels 2" thick, with sub-baffle, leaving over 3" from front of panel to rim of cone. The tone was improved by mounting the sub-baffle 2" further forward, as shown in following sketch.

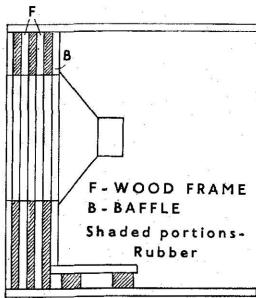

FIG. 31/6.—Q. 3. Speaker Mounting which affected tone.

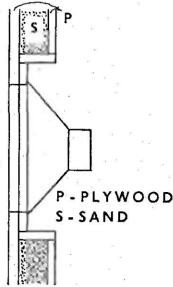

FIG. 31/7.—A. 3. Approved method of speaker mounting in sand-filled panel.

SPEAKER MOUNTING

Q. 4. G. D. G., Guildford

I was attracted by the brick reflex cabinet illustrated in your books, but this would be too large for the room I am using and so also would the wife-appeasing modification in marble. Could similar results be obtained by a single panel of marble (say 30" square) placed securely across a corner with a hole in the floor cut immediately below the speaker so that the space below the boards could supply the 9 cu.ft.? The top would be fitted with the heavy timber lid. Some guidance as to method of fixing the speaker to the panel would be helpful.

QUESTIONS AND ANSWERS

A. 4. We think your idea would work very well. You do not say how the 9 cu.ft. cavity would be formed. If you simply cut a hole in the floor, leaving an opening into the cellar, you would in effect be producing an infinite baffle and this would give very good results; there would be no point in making a port. A port is only required where limited air volume is imposed on the back of the speaker.

As regards mounting, we suggest a strong plywood sub-baffle which would be easy to bolt to the marble. It would also be easier to cut a square hole in the marble than a perfectly round one.

TWO SPEAKERS

Q. 5. W. L., Ashted

I have a 12" speaker and wish to add a Separator and extra speaker, both to be mounted in a substantially built cabinet 4' x 5' 6" x 1' deep. Do you recommend the use of two choke type v.c.—one for each speaker?

A. 5. We do not favour mounting two speakers in one cabinet with a crossover network. It is better to mount the treble speaker on a small open baffle, as this does away with all "boxiness", and improves attenuation below crossover frequency. As regards the volume controls, if your amplifier has flexible bass and treble controls it is not necessary to have additional controls on the speakers. On the other hand, if you wish to have more flexibility, or if the speakers are used in a different room, then the choke v.c. would be justified.

TWO SPEAKERS

Q. 6. H.R., Bishop Auckland

I wish to fit a 12" cloth suspension speaker in a reflex cabinet along with a 6" unit, later adding a Separator.

A. 6. A Cabinet 34" x 18" x 16" with 9" x 3" port would suit the 12" speaker. We would not recommend a 6" unit in the same enclosure. An 8" speaker with high flux density mounted separately on a small baffle would be better.

CONCRETE PANEL

Q. 7. N. S., London, S.E.5

I am constructing a concrete corner reflex. Is there any reason why the front concrete panel should not be continued upwards to form a mounting for the treble unit?

A. 7. The extension to the concrete panel would be excellent, provided you did not have a large area for the treble unit. We suggest an extension 16" high and 18" wide, left quite open around the sides and top.

SMALL CABINET

Q. 8. M. S., Petersfield

I have a cabinet (totally enclosed) which is a cube with 17" internal dimensions, fitted with a 12" speaker. Can I improve matters by making a port and converting from infinite baffle to reflex?

A. 8. We should say that your cabinet is too small for good results. Dr. Olson, of R.C.A., recommends a minimum of 5 cu.ft. for their 12" unit. We think your cabinet would be improved by inserting a vent or vents, but it would not make much difference where you put them as the air-column resonance will be very high.

WALL MOUNTING

Q. 9. A. D. M., Southport

I am primarily interested in installing "wall" speakers for reproduction of organ music, and would like to hear of possible snags before attacking the wall to the disgust of my wife. I intended covering the speaker apertures with wallpaper or decorative grill. As you state in a corner, do you mean speakers flat in the wall or built across the corner?

A. 9. We think you will be satisfied with 15" and 10" units mounted in the wall. Do not cover the openings with wallpaper—expanded aluminium mesh is satisfactory. As regards the corner, it is not possible to build the speakers into a square corner without a lot of structural alterations. Whatever arrangement is adopted there is always some degree of compromise. If you select a wall so that the speakers look into the longest length of the room we do not think you need worry about the corner.

DOUBLE LOADING

Q. 10. F. J. W., Wimbledon.

For demonstration purposes we propose to fit a 10" cloth suspension speaker to a corner horn, loading the back of the cone with a bass chamber in the form of a folded pipe. The enclosed area would be more than 5 cu. ft. whilst the cabinet would be partly of concrete, with Celotex partitions, suitably felted, and having a port area about 9" x 3". We do not anticipate being able to tune the unit/cabinet.

A. 10. We think your idea would be very good. We should however advise a much larger opening than 9" x 3" because you will virtually be making an acoustic labyrinth. Why not start with a big opening, say 16" x 10", and then try the effect of reducing it? We do not think it is worth while trying to tune the unit and the cabinet with this type of horn and labyrinth combination.

MATCHED RESONANCE

Q. 11. D. M., Maidstone

I am basing my calculations for volume of cabinet and port size on an article in Wireless World of October 1949, but I am in some doubt about the cone resonance on which to work.

A. 11. You should base your calculations on the open cone resonance of 60 cycles already given for your speaker. If the cabinet is correctly designed, the resonance will match the cone in the vicinity of this frequency, although some tuning with the port may be required.

PATH LENGTH

Q. 12. D. A. R., Bognor Regis

You say in your letter that the treble speaker should be mounted on a baffle about 16" x 14" because a path length of 6" is adequate with a crossover at 1,000 cycles. What is the path length?

A. 12. The path length is the distance from the front of the cone to the back. Sound waves cancel out at quarter wave length. At 1,000 cycles the wavelength is about 12". Therefore, 3" of baffle at the rim of the speaker prevents cancellation of sound waves at frequencies above 1,000.

V.C. & RESPONSE

Q. 13. W. C. A., Manchester

I have tried a choke type volume control on my treble speaker, but it seems to cut the very high frequencies more than the middle. Is it faulty?

A. 13. No. The human ear loses sensitivity sooner at frequencies above 5,000 than between 1,000 and 5,000. It follows, therefore, that level attenuation will have precisely the effect about which you complain.

APERTURES

Q. 14. C. G. P., East Horsley

In connection with your corner assembly, I should like to know the significance of the position of the loudspeaker in the front panel. Is there any objection to placing it centrally? Also, are the sizes of the side apertures of great importance?

A. 14. The position of the loudspeaker in the panel is not really critical. Some American designers place the speaker and the port quite close together. The sizes of the apertures are, however, of some significance. We find that if you make these openings too big you raise the frequency of the cone and air column resonances. We suggest a total port area not exceeding 60 sq.in. if you make a cavity of similar capacity to ours (9 cu.ft.).

ATTENUATION

Q. 15. W. C. B., Whitehaven

I have been testing my two speakers and crossover system with a Decca constant frequency record and find there is a very considerable overlap. The treble speaker produces well down to 250 cycles and the bass speaker can be heard at 7,000 cycles. This appears to me to be excessive, giving the effect of the two speakers being coupled together in parallel. Does this have the effect of boosting the frequencies between 250 and 7,000 in relation to those above and below? I have no fault to find with the quality of reproduction.

A. 15. The result of your test depends largely on the power used. Assuming a volume level of 70 db at 1,000 cycles (which is not very loud) and attenuation at 12 db per octave, there would still be a volume level of 46 db at 250 cycles. The noise level of a very quiet room is 30 db in comparison. A very steep attenuation is not necessary for good results with Separators. When two speakers are working together, the power is divided between them. Unfortunately, you do not increase the power by connecting extra speakers to a circuit; if this were so, you could step up from 1 watt to 20 watts by the simple expedient of connecting up twenty speakers instead of one. It is also worth while remembering that out-of-phase effects in the acoustic sense do not cause distortion, as they are taking place all the time in any room.

MULTIPLE SPEAKERS

Q. 16. J. F. P., London, S.E.12

I have constructed a large radio|gram|television set with three 12" units for the low notes and three 10" for the high notes, all 15 ohms. I am anxious to know if it is necessary to purchase three crossover units, or if one can be arranged to work the speakers.

A. 16. It is not necessary to have three crossover units. The three bass speakers should be wired up in parallel (and in phase) and connected to the bass output points of the Separator. The three treble speakers should also be connected in parallel and in phase, and joined to the treble output of Separator. The input to the Separator should be connected to the 6.8 ohms tapping of the output transformer. This arrangement should give reasonably good matching.

INSTABILITY

Q. 17. K. B. McG., Letchworth

Is the use of a crossover unit likely to cause instability in a properly built Williamson amplifier owing to phase changes?

A. 17. We have supplied a large number of crossover units to work with Williamson amplifiers and so far as we know they all work. We

QUESTIONS AND ANSWERS

have heard of instances of instability which have been overcome by reversing the leads to one speaker. With properly designed equipment there should be no instability. A good Separator with adequate coil and condenser components introduces a very slight resonant circuit; a poor unit might give a rise of 4 or 5 db at resonance in the speaker, which could be a source of trouble in the feedback circuit.

CROSSOVER at 200 c.p.s.

Q. 18. G. M. J., Dorchester

Is there any objection to a crossover at about 200 cycles?

A. 18. The only objections we know of are bulk and cost of components. The coils would weigh nearly 10 lbs. each and may have a fairly high resistance, and the condensers would be in the 30 or 40 mfd. department; certainly not a commercial proposition. On the other hand, wavelength of notes produced in the bass enclosure would be 5' or more, thus avoiding standing wave effects.

MONITOR

Q. 19. W. H. E., Cootehill, Eire

I have a small cine outfit using two 15 ohm speakers connected in parallel to a $7\frac{1}{2}$ ohm output. I wish to connect a monitor speaker with volume control to the same circuit.

A. 19. We suggest a 15 ohm monitor with 100 ohm potentiometer as v.c., as diagram. This arrangement will increase the impedance of the monitor line as the volume is turned down, thus reducing the power taken from the main speakers.

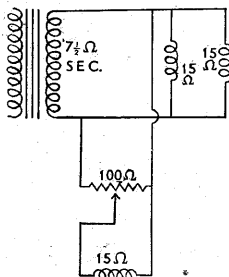

FIG. 31/8.—Suggested method of volume control for monitor speaker.

IMPEDANCE MATCHING

Q. 20. H. A., London, E.C.2

I have a 6 ohm bass speaker, 3 ohm treble unit and crossover. Aural results on the 15 ohm output of my amplifier are good. Is there any objection to the arrangement?

A. 20. Your amplifier has a good feedback circuit, and it is quite satisfactory to be guided by aural results. Matching is no longer critical with such equipment. As loudspeaker impedance normally rises with frequency, a lower impedance in the treble speech coil is not a bad arrangement.

REFLEX LINING

Q. 21. A. D. M., Southport

Although results with my wall mounted speakers were excellent, I have been compelled to dismantle them as the vibration caused annoyance to my neighbours. I have now built a brick corner structure, and I have insulated the dividing wall between the houses with blankets of fibre-glass. Would you advise me to use some of this sound-absorbing material inside the brick enclosure ?

A. 21. We find that the question of lining a brick enclosure depends on room conditions and personal choice. There is no point in trying to absorb the sound ; the idea is to reflect it into the room. My corner cavity at home is not lined but the one in my office has two sides lined with Celotex. This softens the tone slightly and we prefer it under office or demonstration room conditions where there are no curtains or carpets. Some users prefer felt lining.

AIR SPACE AROUND SPEAKER

Q. 22. A. L. M., Old Trafford

In your book Loudspeakers you state that, to relieve deep or resonant reproduction in reflex cabinets, the speaker should be spaced $\frac{1}{8}$ " or $\frac{1}{4}$ " away from the cabinet front. The technical editor of a well known periodical, however, says that the speaker should not be spaced from the cabinet front as this will defeat the whole object of the design. I myself feel that such a space would merely "short circuit" the air pressure on back and front of cone.

A. 22. You are quite correct. But the point is that you are not trying to build a reflex system : surely you are trying to obtain satisfactory reproduction. Unfortunately reflex cabinets often result in boomy reproduction ; in such cases it is worth while to sacrifice "perfection" and try something else. Reflex loading is not an end in itself, it is simply a means to an end. In any case, whatever you do will involve a good deal of compromise.

PARALLEL MOUNTING

Q. 23. A. I. B., Edmonton, Canada

I am planning a domestic record playing system, using the 10" cloth suspension speaker in 30" x 15" x 8" reflex, with smaller unit on open back baffle, connected in parallel. Will the same smoothing of the impedance curve result if a crossover network is employed? Page 48 Loudspeakers, Fig. 22/1, curve B shows the level impedance of parallel connection, and crossover networks have the advantage of keeping L.F. out of the H.F. speaker (and vice versa), but is it possible to combine these advantages?

A. 23. The flat impedance in the bass is only obtained by parallel connection of speakers with different cone resonance. There is a lot in its favour, especially if you like non-resonant results. On the other hand, a crossover network seems to give livelier reproduction. Why not try the parallel arrangement first?

SIZE OF CAVITY

Q. 24. P. H. W., Denver, U.S.A.

I am in the teaching field here in Denver, doing both University and Trade School work in advanced radio and television. I wonder if you can help me to get good results with a 15" speaker with only about 5 or 6 cu.ft. of interior volume. My wife objects to bricklaying or any other kind of permanent "built-in" gracing the living room corners (claims it just might spoil the carpeting), and I don't have room for a telephone booth or any sort of structure. I am wondering what the way is, if any, out of my dilemma.

A. 24. It is very difficult to advise you what to do. We are now making plywood panels, spaced 1" apart and filled with sand. When placed across the corner of a room to give 8 or 9 cu.ft. enclosure we find the bass to be very steady. I think you could reduce this to 6 cu.ft. without raising the air-column resonance too much. We now firmly believe in having open mounting for the treble unit, as any sort of cabinet or horn seems to colour the reproduction. (Such cabinet coloration would be greatly reduced with a free-edge cone.)

CHAPTER 12

DELAYED RESONANCES

It is well known that the conventional response curve does not give a complete picture of the performance of a loudspeaker. For instance, the full significance of the main cone resonance is not always apparent, the degree of development of sub-harmonics is not exposed, and the enormous differences resulting from various methods of coupling the loudspeaker to the air and room are often ignored. Even more important is the question of transient response, or delayed resonances, which was dealt with by D. E. L. Shorter in an article in the B.B.C. Quarterly, October, 1946.

Although this question was touched upon in my earlier "Loudspeaker" book (pp.10 and 62), I have since been in touch with the British Thomson Houston Co. Ltd., who have been kind enough to furnish me with details of tests they have made following the above-mentioned article by Mr. Shorter. A brief description of the method employed by B.T.H. now follows.

A pulse consisting of a train of waves at a selected frequency, and with a square envelope, is applied to the speech coil of the loudspeaker under test. A microphone placed in front of the speaker enables the acoustic output to be viewed on a cathode ray tube. Frequency characteristics are taken on the initial impulse (which correspond to a normal response curve) and at selected time intervals after the cessation of the initial impulse. These often reveal resonances which are not apparent on the steady state characteristic.

The speaker must be mounted in a position so that any echoes from surrounding bodies are negligible in comparison with the transients due to the loudspeaker. For this reason an outdoor position was chosen with the speaker mounted on the roof of a building and pointing upwards at an angle of 45° . A small size Piezo-electric microphone was used, to avoid erroneous results from reflections.

The microphone was mounted at a distance of 18 inches from the speaker, instead of the usual 6 ft. in order to increase the ratio of signal to background noise as much as possible.

Figs. 32 and 33 give frequency responses of two loudspeakers over the range 200 to 7,000 cycles, including the steady state characteristic and those taken at 5, 10 and 20 milli-seconds delay after the end of the impulse.

DELAYED RESONANCES

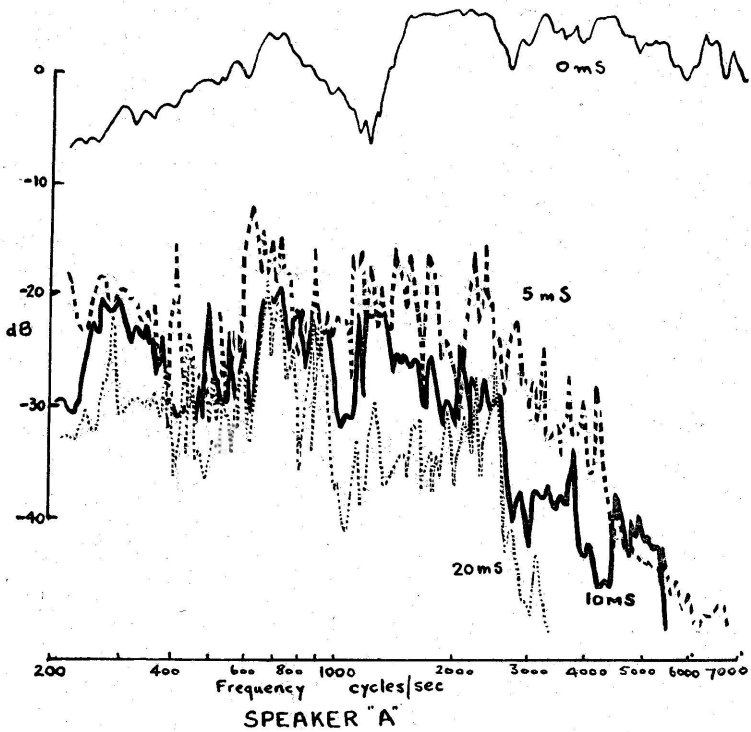
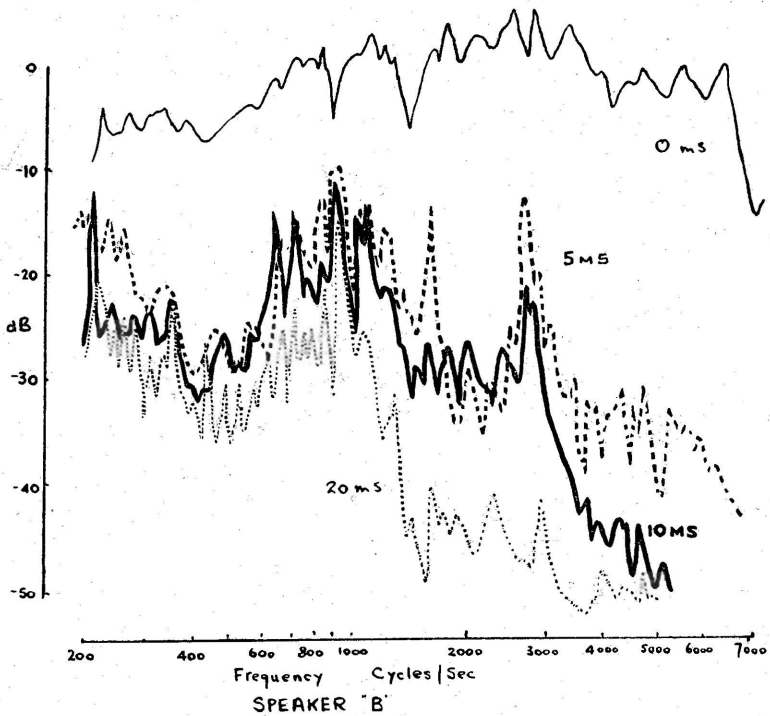

FIG. 32.

Response curves, and Delayed Resonance curves taken at 5, 10 and 20 milli-seconds delay.

In general, it will be seen that speaker A would normally be judged as being worse than speaker B on account only of its steady state frequency characteristics, but the delayed resonance curves indicate that nowhere over this range do the delayed curves approach close



Reproduced by courtesy of B.T.H. Co.

FIG. 33.

to the steady state characteristic, while in speaker B, particularly at 900 cycles, a peak in the delayed response approaches very near to the dip in the steady state curve. Listening tests on the two speakers indicated that B suffered from some distortion and roughness of tone compared with the purer and more pleasing tone of speaker A.

Fig. 34 shows tracings from four photographs of the cathode ray tube picture at four different frequencies in the curves of speaker B.

DELAYED RESONANCES

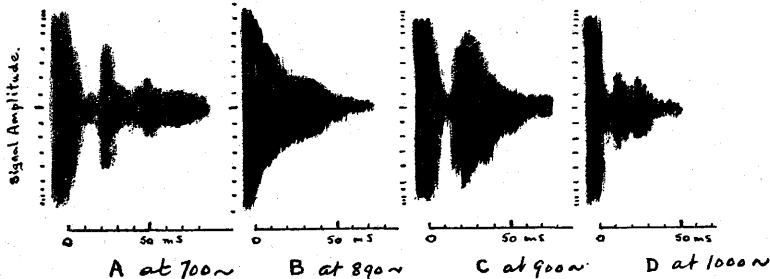

DELAYED RESONANCES OF LOUDSPEAKER B

Reproduced by courtesy of B.T.H. Co.

FIG. 34.

A is at 700 cycles and is characterised by a rapid drop after the initial impulse followed by the output rising and falling until it dies away completely. At B, 890 cycles, the delayed curve is quite near the steady state level. Position C at 900 cycles shows a rapid drop followed by a rise to a maximum at 20 milli-seconds. The best characteristics are seen at D, 1,000 cycles, with a rapid drop and few transient peaks.

These tests confirm the value of a listening test in preference to a normal response curve in the final assessment of loudspeaker performance.

WAVE ENVELOPE

The actual effect of delayed resonances on quality is directly related to the transient form or time characteristic of musical sounds—otherwise known as the wave envelope. The characteristic tone of many instruments is due to the speed at which the sound builds up and decays, a wave-envelope of piano tone being shown in Fig. 34A.

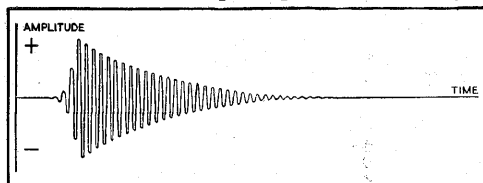

*From
Electronic
Musical
Instruments,
S. K. LEWER*

FIG. 34A.—Wave-form in which amplitude increases rapidly and decays slowly.

When a record is played with the disc rotating backwards, the wave form is reversed and the beauty of tone of a piano is destroyed. The percussive attack and exponential decay of the sound are essential qualities of true piano tone, and uneven delayed resonances in a loudspeaker would distort the wave envelope and detract from true reproduction. No doubt the “piano whine” of many pre-war recordings was due to distortion of the wave-form or transient characteristic during recording.

Similar conditions would apply to other instruments, particularly in relation to starting transients where sustained tones are involved.

CHAPTER 13

THE EAR

The human ear possesses two faculties which have special significance in relation to the reproduction of sound. These are location and discrimination. Let us consider them in turn.

LOCATION OF SOUND SOURCE

This is often referred to as binaural or stereophonic reproduction, which must be more natural in effect than the flat, single channel to which we are accustomed. The power to locate sounds in the ears is related to phase effects below 1,000 cycles, and variation in intensity at higher frequencies. It is natural to turn the head sideways to help to place a sound, thus varying the out-of-phase effect at low frequency and the difference in intensity at high frequency.

The phase effects are, of course, influenced by wavelength. At 1,000 cycles the wavelength is about 12" and waves are, therefore, out of phase at 3", which is less than the distance between the ears. It is interesting to note that in the use of two or more loudspeakers phasing is only important at frequencies below 1,000.¹

The attenuation of sound at high frequency in passing through air is much greater than at low frequencies. It is stated by Dr. Olson that absorption is six times greater at 10 Kc/s than at 1 Kc/s, and the difference in power between the sound received at each ear at 10 Kc/s may be 20 db. Applied to reproduction of sound, this means that much stronger "top" may be required for best results in a very large room or hall than in a small room. For the same reason, a grand piano is used for concert work with the hammer felts left hard, and often has the upper register tuned slightly sharp to increase the effect of brilliance in a large hall.

SOUND DISCRIMINATION

This faculty is shared by most ears, but in a varying degree. No doubt those people with the sense strongly developed derive most interest and pleasure from orchestral performances, as they are able to follow the different instruments and select certain groups for special attention. The same power may be cultivated in respect of noise, and must be used in factories, where the noise level is very high, in order to carry on a conversation. A suitable choice of pitch of voice enables experts to converse in a weaving shed with a noise level of 90 db, where the stranger is virtually deaf and dumb.

In the same way it is possible to concentrate on the music to the partial exclusion of needle scratch when listening to record reproduction. It is suggested that practice in this direction is helpful in enabling the listener to enjoy a wider frequency range.

¹The above remarks about phase effects at high frequencies refer only to acoustics. The importance of H.F. phase shift in amplifier circuits with negative feedback is a separate problem, effectively dealt with by "Cathode Ray" in an article in *Wireless World*, May 1949, entitled "When Negative Feedback isn't Negative."

CHAPTER 14

FREE-FIELD SOUND ROOMS

In order to avoid reflection from walls and reverberation effects, measurements of loudspeaker performance are often taken out of doors under what are known as free-field conditions. Dependence on weather and movable equipment makes such tests often difficult and inconvenient to carry out. It is by no means easy to construct a soundproof anechoic room to give free-field conditions. Such a room must be large to avoid error at low frequencies and the absorption coefficient of the wall treatment must be high at all frequencies involved in the tests.

As a matter of general interest, details of one English and one American design now follow.

G.P.O.

The writer is indebted to the Engineer-in-Chief of the Post Office for permission to give details of their recently constructed "dead" room. The modern form of treatment is an assembly of wedge-shaped pieces of suitably porous material (in this case glass-wool, covered with muslin) which provide the quantity and depth needed for absorbing at low frequencies while presenting no regular surface for reflecting higher frequencies back into the room.

The following two diagrams, Figs. 35A and B, show the efficiency of the new treatment compared with a typical system of blankets of glass-wool about a yard thick previously used.

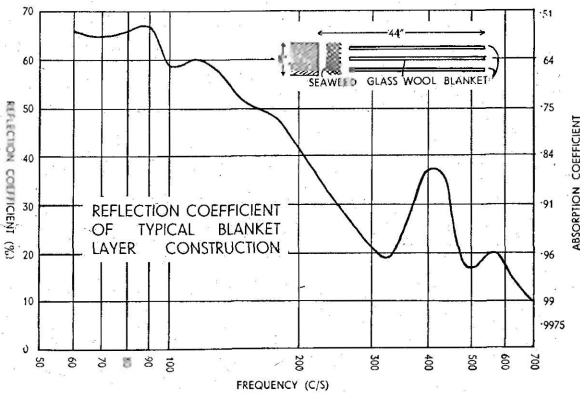
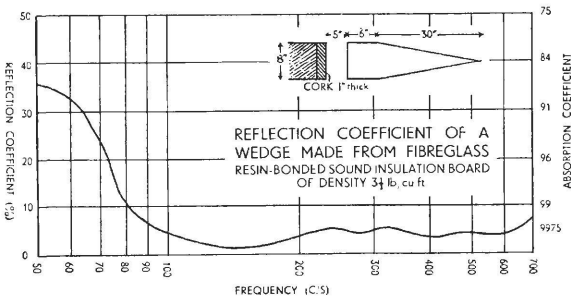

FIG. 35.—Reflection and absorption co-efficients of different wall treatment.
A.—Typical glass-wool blanket layer construction.



Reproduced by permission of Engineer-in-Chief, General Post Office

B.—Wedge made from fibre-glass.

The dimensions of the room (which was the largest existing one available for the purpose) were 19 ft. × 20 ft. × 13½ ft. high before the acoustic treatment was added, being acoustically dead at all frequencies from 85 c/s upwards. Illustrations of the room partly assembled and in its finished state now follow.

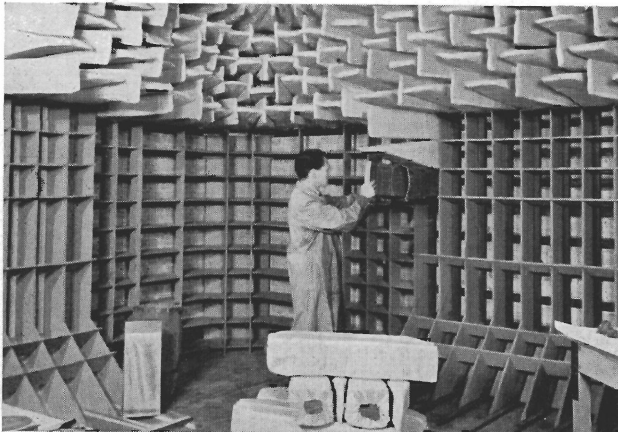

FIG. 36.—Post Office dead room during construction.



Reproduced by permission of the Postmaster General

FIG. 37.—Completed dead room with microphone.

An air space of about 4 in. is left behind the wedges to improve absorption at very low frequencies. The same treatment is applied to floor and ceiling. Each wedge is about 3 ft. long and 8 in. square at the base, and some 3,000 of them were used.

The absorption of sound in this room is so good that it is almost impossible to hear the voice of a man speaking loudly if he stands with his back towards the listener.

AMERICAN SYSTEM

I am equally indebted to the Publishers of Olson's "Elements of Acoustical Engineering" for permission to give details of another type of free-field sound room, Fig. 38.

The treatment here consists of 7 ft. lengths of inch thick Ozite spaced 2 ft. apart at right angles to the walls, floor and ceiling, with 4 ft. baffles between. The inside dimensions of the room after treatment were 32 ft. \times 20 ft. \times 20 ft. high.

It is pointed out that deviation at low frequencies begins when the thickness of the treatment is about a quarter wavelength.

Thus the efficiency is maintained down to approximately 40 cycles, the wavelength of 7 ft. being about 160 cycles.

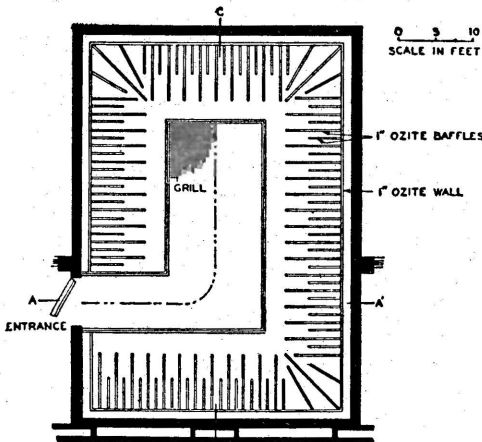

From Olson's "Elements of Acoustical Engineering"

FIG. 38.—Plan of free-field sound room with 7 ft. and 4 ft. baffle treatment.

CHAPTER 15

REPRODUCTION IN SCHOOLS

In view of the importance and high standard of school broadcasts to-day, a word on the special problems involved may be worth while.

REVERBERATION

A lot of trouble is experienced in older schools from echoes and reverberation. Classrooms often have large windows and hard bare walls, making reproduction of speech extremely difficult. Direct reflection of sound from walls could be reduced by curtains or formation of curved surfaces. Partial treatment at low cost on the following lines would be helpful.

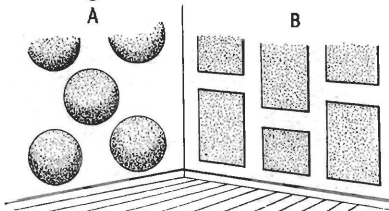

A.—Convex surfaces.
B.—Absorbing material
or curtains located in
patches.

FIG. 39.—Partial treatment of walls, for diffusion of reflected sound waves.

Equipment with wider response than the usual superhet. is required for clarity of speech, as the worst reverberation effects do not occur above 5,000 cycles per second. School installations should be specially designed.

Fig. 39A shows a section of Burgess "Acousti-pad" sheet, which is specially constructed for absorbing sound and reducing reverberation. Sound waves filter through the perforations and are subdued by the absorbent blanket. The facing sheet is available in metal, plastics or plywood. The system is very efficient.

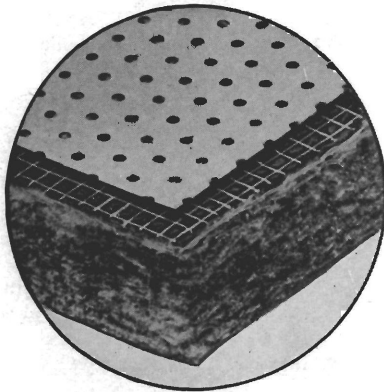

FIG. 39A. "Acousti-pad" sound absorbent panelling.

*Courtesy Burgess Products Co. Ltd.,
Hinckley, Leics.*

LOCATION OF SPEAKER

The best position for the loudspeaker is one which approximates the position normally taken up by the teacher, say, about 5 ft. 6 in. high in full view of the pupils. If two speakers are used, they should be placed close together and not in opposite corners.

In a classroom of oblong shape, the speaker will give the best results when facing the longest length, but if the desks face the shorter way it would be advisable to have the source of sound in front of the scholars in preference to a side position. See Fig. 40 and 41.

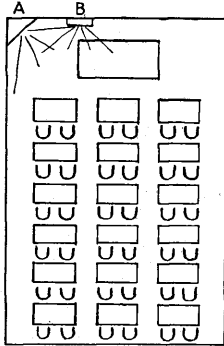

FIG. 40.—Classroom. Speaker positions A or B satisfactory.

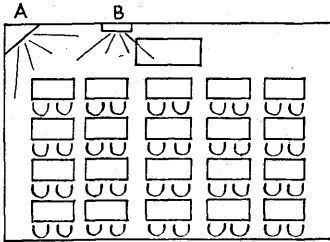

FIG. 41.—Classroom. Speaker position A preferred. Position B second choice.

Avoidable distortion often occurs in schools as a result of turning the main volume control of set or amplifier fully on, and then turning the speaker control drastically down. The main control should always be set as low as possible, and should never be advanced to the point where overloading begins, as the extra noise will result in reduced clarity in the classrooms.

LOW LEVEL COVERAGE

In the worst cases of echo and reverberation, a solution of the speaker problem may generally be found by using a number of loudspeakers, each working at a low level and located to cover a small section of the audience, as shown in the next diagram.

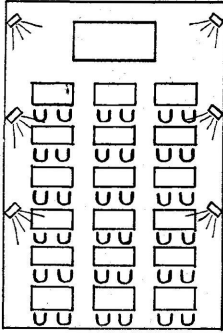

FIG. 42.—Arrangement of speakers for low level distribution of sound, to reduce reflections and the effect of excessive reverberation.

Ordinary cabinet speakers may be used with 8" or 10" units. They should be placed 8 ft. or 10 ft. high, with a downward tilt, and in the same phase.

NEW SCHOOLS

In many of the new schools, which are being built or planned, wireless is being considered as an integral part of the plans like heating or lighting. This means that loudspeakers will be fixed in the best positions, and in some cases non-resonant acoustic chambers are being built in bricks and mortar at low cost. Trailing wires will be avoided and final results will no doubt be far ahead of the average standard to-day.

Architects are also paying attention to the question of acoustics in the design of assembly halls and classrooms, which will greatly simplify the problem of clear reproduction.

CHAPTER 16

INTERMODULATION

A lot is heard about this complaint nowadays and, as its effects are heard in the loudspeaker, it is necessary to consider the problem in a book on sound reproduction. The trouble may arise in any part of the chain from microphone to loudspeaker, and some knowledge of the science of high frequency radio transmission is necessary for a complete understanding of the phenomenon, which, unfortunately, I do not possess.

I have to thank my technical sub-editor, Mr. Beaumont, for the following brief description and explanation.

“Intermodulation distortion is, briefly, the production of combination-frequency tones at the output by the non-linearity of an amplifier, network, or loudspeaker, when two or more sinusoidal voltages of specified amplitude are applied at the input. Thus a combination of 400 c.p.s. and 4,000 c.p.s. could result in new frequencies in the output of 4,400 and 3,600 c.p.s. in addition to the fundamentals of 400 and 4,000, with possibly the generation of harmonics of all the resulting frequencies. The mechanism is a counterpart to the modulation of a high frequency radio transmitter by low frequencies, in which the high frequency waves act as an envelope for the low frequency modulation.

The sketches show the resulting envelope for the case given above :—

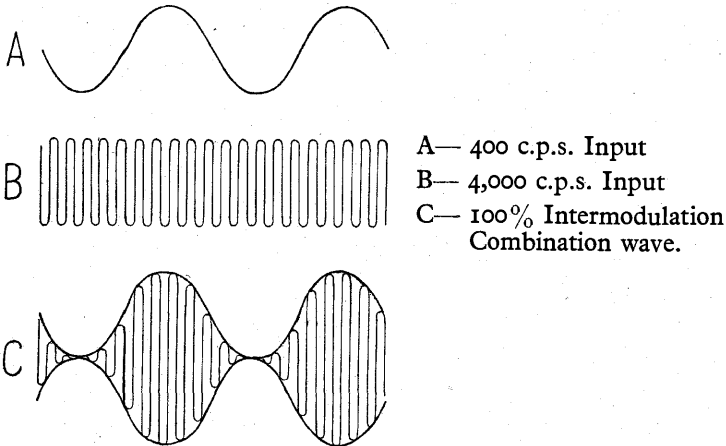

FIG. 43.—Diagram to illustrate 100% intermodulation.

INTERMODULATION

The least distressing effect is that in the above example the 4,000 c.p.s. wave varies in amplitude at the rate of the lower frequency component and gives rise to a harsh fluttering. An analysis of the envelope shows the familiar sideband mechanism of f_1 , f_2 , $f_2 + f_1$ and $f_2 - f_1$. The non-linearity which might give rise to such effects could equally lie in any section of the chain. Where evident distortion of one component of the signal arises—usually the lower frequency (owing to amplitude limitation over part of its swing)—intermodulation with the higher frequencies will certainly be introduced.”

The situation appears to have been foreseen and expressed in a nutshell by Shakespeare :—

*Find out the cause of this effect;
Or rather say, the cause of this defect,
For this effect defective comes by cause.*

HAMLET, ACT II, SC. 2.

Perhaps the following illustration of a specific case of distortion will help to throw more light on the problem.

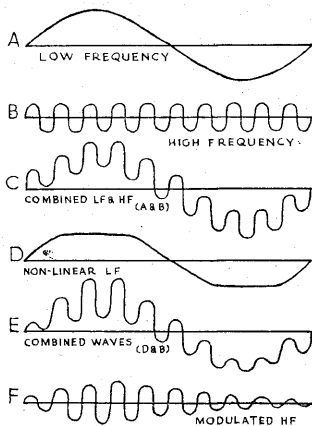
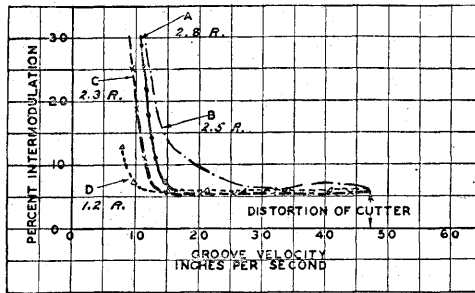

FIG. 43/I.—Typical wave formations showing effect of Intermodulation.

The two pure tones of A and B would combine to give curve C, but non-linear low frequency D would result in the combined wave E. Removing the low frequency component from E would leave the modulated H.F. pattern of F, which shows distortion. This would be heard in the loudspeaker as harshness, or, in severe cases, as an actual rattle.

The use of multiple speakers and crossover networks can remove only the intermodulation products which arise in the speakers, but the improved performance of the two or more speakers may expose more than ever any intermodulation trouble originating in previous stages such as record, pick-up or amplifier. Intermodulation is a form of distortion often due to overloading.

Some interesting tests of intermodulation in record reproduction are shown in an article by H. E. Roys in the "Proceedings of the I.R.E.," October, 1947. When using the intermodulation method of testing harmonic distortion, a high frequency is used at 12 db lower level than the low frequency, and the result is about 4 times as great as the normal harmonic distortion. In the tests described, frequencies of 400 and 4,000 cycles were used, the effect of different needles, surface speed and groove formation being measured.



From Proc. I.R.E., October, 1947. H. E. Roys, R.C.A.

FIG. 43/2. Intermodulation distortion with pickups of different tip radii, in narrow groove.

- A ———●——— 2.8 mil. tip radius.
- B ————●——— 2.5 mil. tip with approx. 1.2 mil flat.
- C ———x———x 2.3 mil. tip radius.
- D ———Δ———Δ 1.2 mil. tip radius.

The main points about Fig. 43/2 are the reduction in distortion at slow speed with a fine needle in a sort of microgroove, and the general level of distortion from cutter amounting to rather more than 1% harmonic. Note the importance of correct needle diameter.

Fig. 43/3 shows the results with the same recording made from an excessively polished master. This excessive polishing causes wear on the ridges, which in turn deforms the bottom of the groove in the record. The effect of needle diameter is now reversed, and the finest point, which fits low in the groove, shows 30% intermodulation at a surface speed of 40 inches per second, which is about 10" diameter

INTERMODULATION

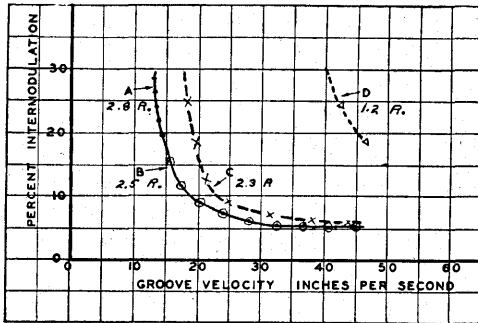

From Proc. I.R.E., October, 1947. H. E. Roys, R.C.A.

FIG. 43/3. Intermodulation distortion - excessively polished master.

- A —●—●— 2.8 mil. tip radius.
- B —○—○— 2.5 mil. tip with approx. 1.2 mil. flat.
- C —x—x— 2.3 mil. tip radius.
- D —△—△— 1.2 mil. tip radius.

at 78 r.p.m. Also, the needle with a worn surface produced no more distortion than the .0028" radius. Thus a steel needle which wears to fit the groove will give better results on worn records than a fine needle.

Although these tests are more directly related to needles and surface speed than to loudspeakers, they are included here because they help in a better understanding of intermodulation effects, and they also demonstrate how faults at low frequency show up at higher frequencies. Many people find this hard to believe. They improve efficiency by installing two speakers and a crossover network, and if they then hear a rattle in the high note speaker—which they never heard before—they not unnaturally blame the speaker or the separator. In many cases the distortion originates in the low frequencies and is actually present in the L.F. speaker, where it is not objectionable to the average ear. A glance at curve D in Fig. 43/3 should convince the most sceptical that a percussion note at 400 cycles reproduced under those conditions would be likely to cause a rattle in a speaker at higher frequencies also being produced.

That general distortion would occur is obvious. It should be added that a rattle can also be caused in a speaker below 10,000 cycles as a result of difference tones from distortion occurring at frequencies above 10,000.

DISTORTION IN LOUDSPEAKER

These faults are always more likely to be heard on record reproduction than radio, from the following causes :—

1. Worn records and badly fitting needle.
2. Prevalence of 1% or more harmonic distortion in cutting and processing of records.
3. Deterioration of quality towards the centre of disc.
4. Difference tones from resonances at high frequencies.

Any distortion in the amplifier is added to the previous non-linearity, and the combined result may be sufficient to cause an actual rattle in the loudspeaker.

The power-handling capacity of the speaker has nothing to do with the problem. Overloading and intermodulation in records or amplifiers cannot be overcome by using larger speakers. The aural effect may be modified by using a speaker with a poor high note response, because harmonic distortion is most objectionable to the ear at the highest frequencies.

Far be it from me to suggest that loudspeakers cannot develop faults and give trouble. I know from bitter experience that they can—and do. My plea is that the speaker should not be blamed when all the evidence points to other sources. It is an interesting point that as non-linearity in the bass chain will cause intermodulation at much higher frequencies, increasing the L.F. response of such an amplifier may actually accentuate H.F. distortion in the reproduction.

CHAPTER 17

DYNAMIC RANGE AND TONE QUALITY

It is well known that large volume in recording and transmitting must be kept below a certain level to avoid overloading, and very soft passages must be increased to maintain audibility above the background noise level of the system.

Thus a total dynamic range of 95 db in the performance of a large orchestra may have to be contracted to 40 or 50 db. It is, however, unlikely that 95 db represents the total range heard by a member of the audience, unless he finds himself sitting immediately in front of the brasses. 75 db would be a more likely estimate, but a reduction to 50 db still removes some of the life. No doubt this accounts for the impression of greater realism which is noticed in violin or piano recitals compared with large orchestral reproduction. Such recitals would call for very little suppression.

There is another side to this question of loudness. When a note is sung or played more loudly, there is a change in the harmonic structure of the tone. This is shown in Fig. 44.

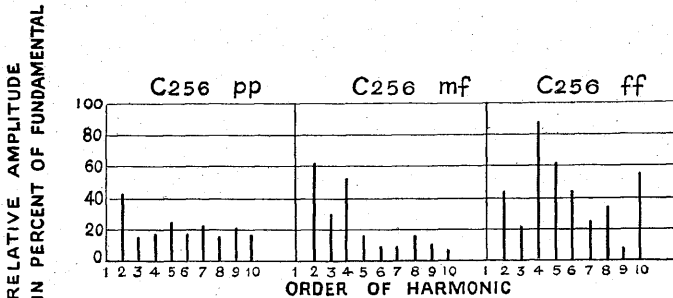

From Journal of Ac. Society of America.

FIG. 44.—Harmonic analysis of piano note struck with different degrees of loudness.

As the loudness is increased, the strength of the overtones is brought out.

It follows that volume compression must upset the aural balance between loudness and harmonic structure.

Looked at from the opposite angle, reduction in loudness results in lower harmonic content, or softer tone. In Wood's "Physics of Music" there is an explanation of the wolf note of the violin. There are two main resonances in a violin, one at about 270 cycles due to the natural frequency of the internal air, and another around 500 cycles which is one of the resonant frequencies of the belly and also the pitch

of the wolf note. At this frequency the string indulges in a form of frequency doubling and vibrates at 1,000 cycles unless controlled by the skill of the player. When loaded by adding a mute this resonance drops to about 330 cycles. The following curves have been computed from the foregoing information, Fig. 45.

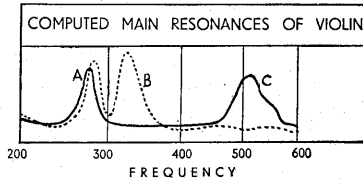

- A.—Resonance of contained air.
 B.—Resonance of bridge and belly with mute.
 C.—Resonance of bridge and belly without mute.

FIG. 45.—Computed main resonances of violin.

Everybody knows how the tone of a violin is softened and made rather husky by the addition of a mute. The point the writer wants to make is that the change of tone is actually due to lowering the resonance and reducing overtones. If you now reproduce the muted tone and increase the volume by artificial means, the result is unreal, which is another aspect of the problem of dynamic range and natural volume. Incidentally, it explains the peculiar and monotonous case of the crooner. A crooner selects a soft tone of voice, similar to a muted violin, uses no dynamic range worth mentioning, and the rest is artificial amplification.

Attempts have been made to replace volume compression at the source by automatic volume expansion in the reproducing equipment, but have not met with great success. It hardly seems possible to ensure that the expansion which takes place will agree with the previous compression, and the result is often like listening to an organist with one foot glued to the swell pedal.

It is clear that any improvement in recording which reduces the level of background noise and extends the dynamic range is a step towards greater realism in reproduction.

There is also the importance of dynamic range in the musical sense to be considered. The most obvious example is music representing a march past, where the climax is in the middle of the piece; but most compositions require to be seen as a whole in the dynamic sense. Many direct recordings, where a rehearsal is impossible, are marred by undue suppression of the climax to avoid overload. Full marks must be awarded to recording engineers in general who succeed in limiting the dynamic range without destroying the dynamic peaks in the musical sense.

This must call for a rare combination of art and skill.

CHAPTER 18

CROSSOVER NETWORKS

The ever-increasing use of these devices seems to call for an investigation into the way in which they work, coupled with an explanation in terms which will be comprehensible to the average non-technical reader.

The crossover network, or separator, is usually located in the voice coil circuit for reasons of economy, convenience and adaptability. The arrangement can be applied to existing amplifiers, changes may be made to the crossover circuit and speaker system without disturbing the rest of the equipment, and (being a low impedance device) there is no trouble from interference, hum pick-up, or loss of quality in the wiring, which may be run 20' or 30' on either side of the network with impunity.

It is of course possible to embody the crossover system in the amplifier, with results which are probably superior to the more common external method. The design virtually involves the construction of two amplifiers, each with the necessary response lifts and controls. The two output transformers can be suitably designed for the job without much difficulty—a large one with ample inductance for the bass—a small one with very low leakage inductance for the "highs". Excellent results are possible, with very flexible control of power and response between the associated loudspeakers, but with an addition of 50 per cent or perhaps 75 per cent to the cost of the amplifier. Fig. 45/1 gives a suitable circuit with crossover at 600 c.p.s.

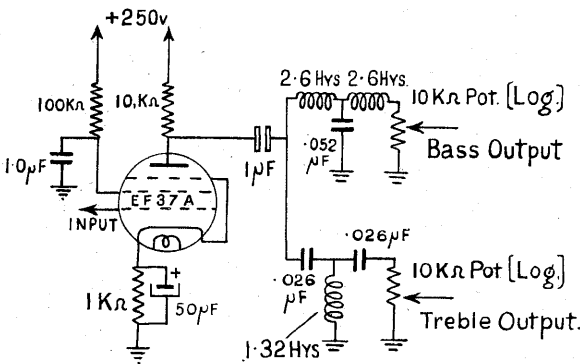

FIG. 45/1.—T-section Filters for independent Bass and Treble Amplifiers.

Another arrangement is to locate the network in the plate circuit of the output valves and use two transformers. Very good results are possible, and a suitable circuit is given in the next diagram for those who may wish to try this high impedance crossover, which only calls for moderate values of inductance and capacity.

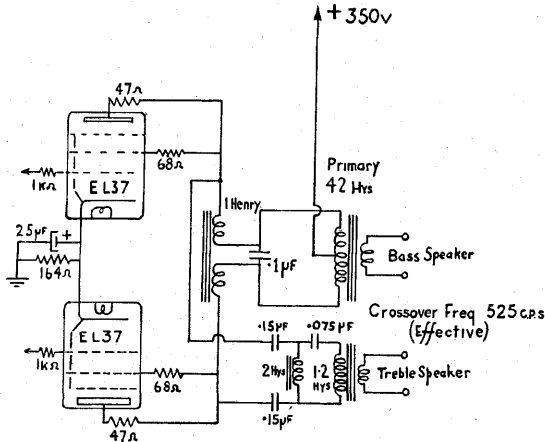

FIG. 45/2.—High Impedance crossover network, as used with Ambassador Corner Speaker described in "Loudspeakers".

The conventional low impedance networks, with which we are mainly concerned in these investigations, may be divided into four main classes :

Type	Approximate Attenuation
1. Simple high-pass or low-pass filter	3 db per octave
2. Quarter section networks	6-8 db per octave
3. Half section networks	12 db per octave
4. Full section networks	18 db per octave

It is, however, important to note that the attenuation is affected by the impedance of the loudspeaker. Results will therefore vary with different speaker units, and will also be affected by the type of cabinet or baffle used, as this affects the impedance.

Another interesting point is that when the treble unit is mounted on a small baffle of appropriate size, the L.F. attenuation is assisted by the loss of 6 db per octave which occurs at frequencies below the effective area of the baffle.

FUNCTION OF COMPONENTS

A network is made up of condensers (capacities) and coils (inductances) which may be said to function as follows :

The reactance of a condenser varies with frequency ; in other words, its A.C. resistance increases as the frequency is lowered and *vice versa*. It follows, therefore, that a condenser placed in series with a voice coil will tend to reduce the current in the voice coil more and more as the frequency is lowered. Conversely, if the condenser is placed in parallel with the voice coil it will tend to reduce the current in the coil as the frequency is raised, because the resistance of the condenser drops to the point where it by-passes the current.

Now the reactance of the choke or coil functions in the reverse way. Its resistance to A.C. increases as the frequency is raised, and its resistance goes down as the frequency is lowered, so it has the opposite effect to a condenser.

It will be clear that, given a suitable choice of component values, almost anything can be done to the response of the loudspeakers. The action of the condensers and coils is in the nature of a combined operation, and elements which normally pull in opposite directions may be arranged to pull together. Some indication of how different component values affect results will be found in the diagrams which appear in subsequent pages of this chapter.

LIST OF REACTANCE VALUES

The following tables of reactance values at different frequencies will be helpful in the selection of suitable components, or in estimating their effect on the speakers.

Reactance of Condensers.

		at 50	500	1,000	5,000	10,000 c.p.s.	
24 Mfd	..	133	13	6.7	1.33	.667	ohms
12	„	267	26	13	2.67	1.335	„
4	„	800	80	40	8	4	„
1	„	3,200	320	160	32	16	„
.5	„	6,400	640	320	64	32	„
.25	„	12,800	1,280	640	128	64	„
.1	„	32,000	3,200	1,600	320	160	„

Reactance of Inductances.

	at 50	500	1,000	5,000	10,000 c.p.s.	
0.5 mH ..	.157	1.57	3.14	15.7	31.4	ohms
1 " ..	.314	3.14	6.28	31.4	62	"
2 " ..	.628	6.28	12.56	62	125	"
3 " ..	.942	9.42	18.84	94	188	"
4 " ..	1.25	12.56	25.12	125	251	"
5 " ..	1.57	15.7	31.4	157	314	"
0.1 H ..	31.4	314	628	3,140	6,280	"
0.5 " ..	157.0	1,570	3,140	15,700	31,400	"
1.0 " ..	314.0	3,140	6,280	31,400	62,800	"

CROSSOVER BENEFITS

The advantages to be derived from crossover networks may be summarised as follows :

1. Intermodulation distortion between bass and treble in one speaker is avoided.
2. Bass speaker can be designed and housed for maximum L.F. performance ; treble speaker for maximum H.F. efficiency.
3. The speakers can be suitably placed, say bass unit near the floor, treble unit 3' or 4' higher.
4. A choke type volume control may be fitted to each speaker to provide additional tone control if needed.
5. Speakers of different impedance may be tried, e.g. 15 ohm bass with 10 ohm treble unit to increase the H.F. output and flatten the impedance curve. Alternatively, a higher impedance may be used in treble to reduce output.
6. Considerable latitude in component values is permissible, especially with quarter section networks ; even with half section networks variations of 25 per cent are passable.
7. Loss of power is not serious, being about 1 db with quarter section or 2 db with half section networks, assuming components of the correct type are used.
8. As only low voltages are met with in the speaker circuit and robust components are used, long life free from breakdown is a normal expectation.

The following ten diagrams give typical circuits with values suitable for use with 15 ohm speakers, with crossover at 1,000 cycles.

CROSSOVER NETWORKS

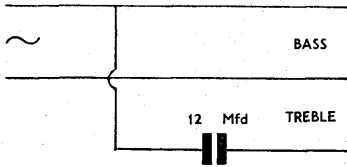

N.W.1. Simple high-pass filter

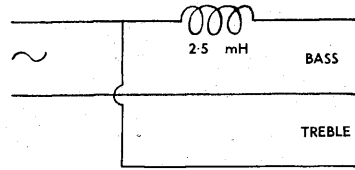

N.W.2. Simple low-pass filter

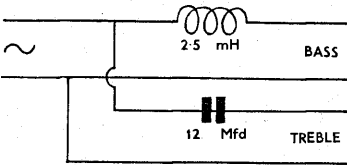

N.W.3. Quarter Section, Parallel

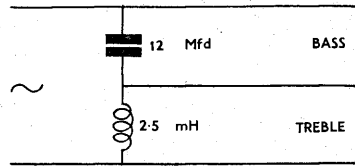

N.W.4. Quarter Section, Series

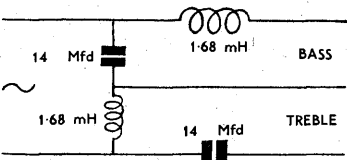

N.W.5. Half Section, Series, Constant resistance

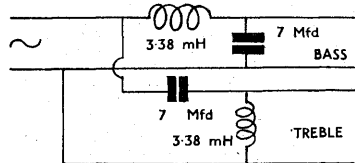

N.W.6. Half Section, Parallel, Constant resistance

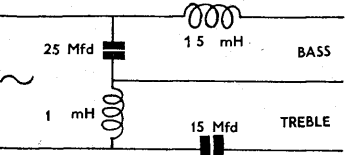

N.W.7. Half Section, Series, Filter type

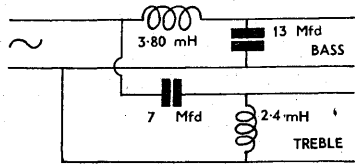

N.W.8. Half Section, Parallel, Filter type

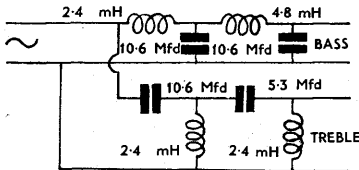

N.W.9. Full Section Parallel Network

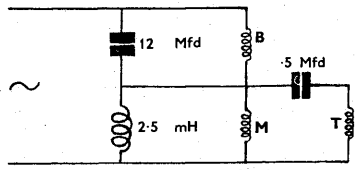

N.W.10. Three Speaker circuit.
Crossover at 1000 & 5000 cycles

FIG. 45/3.—Typical Crossover Circuits.

VARIOUS COMPONENT VALUES

The values shown in circuits N.W.1 to N.W.10 are for 15 ohm speakers with crossover at 1,000 cycles. To arrive at other values theoretically proceed as follows :

7.5 ohm speakers, multiply all C values by 2.
divide all L values by 2.

3 ohm speakers, multiply all C values by 5*.
divide all L values by 5.

* Hardly necessary in practice. A factor of $2\frac{1}{2}$ would be adequate in most cases.

As regards crossover frequency, the component values are in inverse proportion to the frequency. Therefore, to cross over at 500 cycles instead of 1,000, multiply all C and L values by 2. To cross over at 2,000 cycles instead of 1,000, divide all C and L values by 2.

TESTS

If we now examine the ten circuits in turn, along with diagrams of actual tests made with selected types, it should be possible to form a general picture of what happens under working conditions. The graphs of attenuation have been taken by measuring the speaker output—not by reading the voice coil voltage. Thus a drop of 5 db with a given condenser at a stated frequency means that the insertion of the condenser actually reduced the speaker output by 5 db. It will

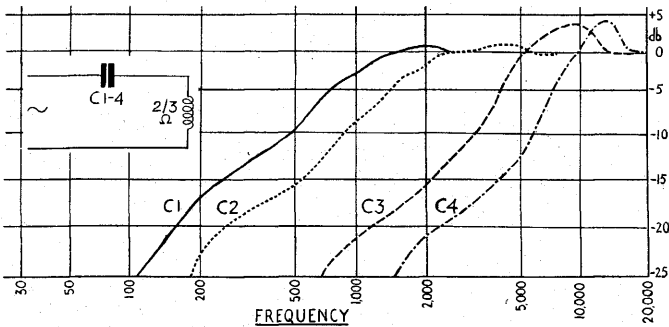

C1 = 24 Mfd C3 = 2 Mfd
C2 = 12 " C4 = 1 "

FIG. 45/4.—Effect of series condenser on 2-3 ohm speaker.

CROSSOVER NETWORKS

be observed that in many cases the results with certain component values do not agree with theoretical calculations, especially at higher frequencies, where condenser values are lower than expected for a given result. This is due to the fact that speaker impedance varies with frequency, and a speaker nominally rated at 15 ohms may have an actual impedance as high as 30 ohms at 5,000 c.p.s. Compromise is always necessary.

Circuit N.W.1 Simple high-pass filters. Figures 45/4 and 45/5 show the effect of different condenser values in series with the voice coil. The L.F. attenuation is naturally more pronounced with 3 ohm than with 15 ohm speakers.

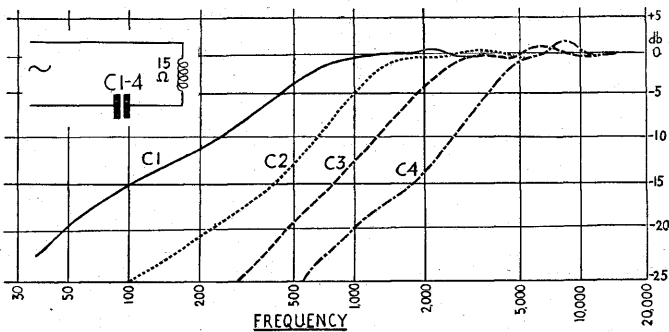

C1=12 Mfd C3=2 Mfd
C2= 4 „ C4= .5 „

FIG. 45/5.—Effect of series condenser on 15 ohm speaker.

RESONANCE

It is important to note that in all these condenser/inductance circuits there is a resonance which generally occurs about one octave above the start of cut-off. This is shown in the graph by a rise in output from speaker amounting in some cases to 4 db, the resonance being more pronounced at the higher frequencies. This could lead to trouble from phase shift in an amplifier bordering on instability from excessive feedback. With the usual 1,000 cycles crossover, the effect of the resonance is only 1 to 1½ db rise at 2,000 cycles, which is barely audible and should be harmless. The calculated resonance for typical circuits comes out as follows :

Inductance (Voice coil)	Condenser	Calculated Resonance
320 micro H	.5 Mfd	12,500 c.p.s.
" "	2.0 "	6,400 c.p.s.
" "	4.0 "	4,400 c.p.s.
" "	12.0 "	2,400 c.p.s.
1.1 milli H	.5 Mfd	6,800 c.p.s.
" "	2.0 "	3,400 c.p.s.
" "	4.0 "	2,400 c.p.s.
" "	12.0 "	1,400 c.p.s.

An estimate of voice coil inductances may be made from the following examples :

Diameter of coil	D.C. Resistance	Nominal Impedance	Inductance
1"	1.65 ohms	2.5 ohms	210 micro H
1"	1.92 ohms	3.0 ohms	320 "
1 3/4"	10.00 ohms	15.0 ohms	1.1 milli H
2"	9.00 ohms	15.0 ohms	1.6 "

To return to the Circuit N.W.1, the next diagram is intended to show the effect of placing a choke in parallel with the 15 ohm voice coil, in addition to the series condenser used in the previous figure. A suitable value of inductance increases the attenuation by 3 to 4 db per octave, giving a total cut of about 8 db per octave, which ties up with results obtained with the equivalent quarter section circuit N.W.4.

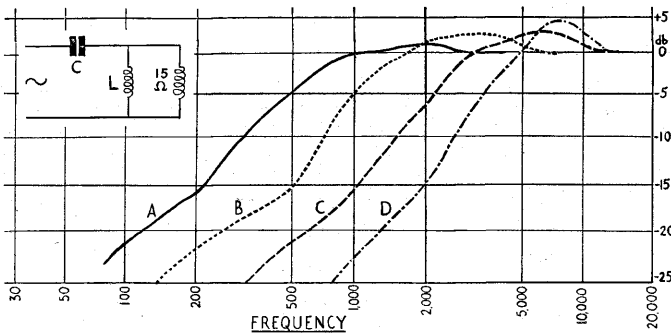

C	L
A = 12 Mfd	2.38 milli H
B = 4 "	1.93 "
C = 2 "	0.50 "
D = 1 "	0.30 "

FIG. 45/6.—Curves to show improved bass cut obtained by adding suitable choke to previous condenser circuit.

POWER LOSS

Before leaving the series condenser question, it is worth noting that the value used should not be so low that there is serious loss of power at all audio frequencies. The effective resistance may be very high with low values of capacitance. For instance, the voltage drop in a 15 ohm voice coil with .25 Mfd in series compared with .5 Mfd is as follows :

Constant input at 2 volts.

Frequency.

	1	2	4	6	8	10	12	15 kc
With .5 Mfd	0	.18	.60	1.32	2.40	2.90	2.80	2.25 volts
With .25 „	0	.05	.24	.50	.93	1.50	2.15	2.42 „

Note resonance at 10 kc with .5 Mfd.

With 3 ohm speakers the losses with 1 Mfd would be comparable with .25 Mfd at 15 ohms.

Circuit N.W.2. It will be seen from the next two diagrams that a choke in series with voice coil gives attenuation at about 3 db per octave. The addition of a suitable condenser to the circuit improves the cut by about 4 db per octave.

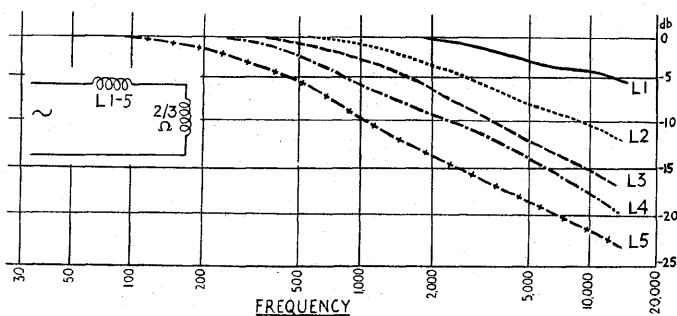

L1=0.15 milli H

L2=0.50 „

L3=0.75 „

L4=1.20 „

L5=2.25 „

FIG. 45/7.—Effect of Inductance in series with 2-3 ohm speaker.

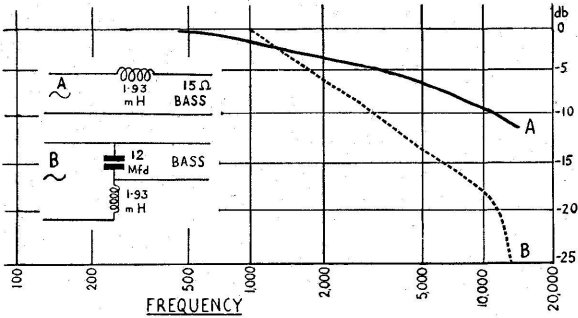

FIG. 45/8.—Effect of Inductance in series with 15 ohm speaker, also condenser in parallel with voice coil.

Circuit N.W.3. Quarter section, parallel. As the previous tests have already indicated, the attenuation with this circuit is only about 3 db per octave, and is more suitable for use as a tone control than a crossover section.

Circuit N.W.4. Quarter section, series. Although using only the same components as the previous circuit N.W.3, this arrangement will give attenuation at about 8 db per octave with a suitable choice of values. It combines economy, efficiency and flexibility. The power loss is not more than 1 db.

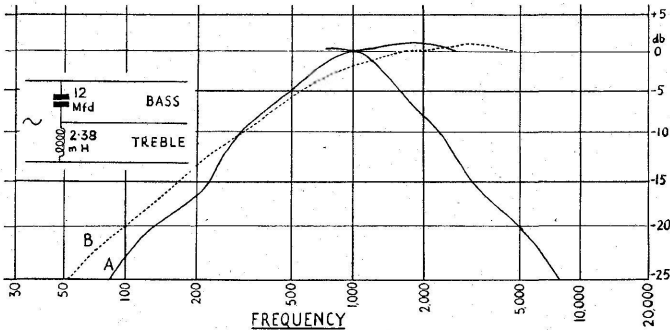

FIG. 45/9.—Attenuation curves with circuit N.W.4.

A—with two 15 ohm speakers.

B—effect of replacing treble unit by 3 ohm type.

CROSSOVER NETWORKS

A comparison was made with the more expensive half section network of N.W.5 by means of 6 pole change-over switch and wide range loudspeakers, but no change in the quality of reproduction could be discerned. There was a slight audible drop in volume with circuit N.W.5. It is possible to obtain strong H.F. response with circuit N.W.4 by using a 3 ohm treble speaker along with a 15 ohm bass unit. The effect on the attenuation is indicated in the diagram.

IMPEDANCE

When the speaker impedances suit the network, the total load may be taken as the same as one speaker. In fact, the following impedance curve of two 3 ohm units is extremely attractive.

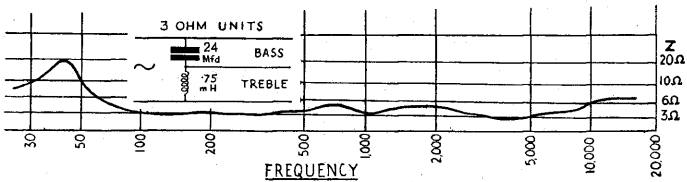

FIG. 45/10.—Impedance curve of two 3 ohm units with crossover N.W.4.

As a matter of interest and curiosity, an impedance curve of the 3 and 15 ohm combination was run off. In spite of the fact that the chart looks as though the patient were just recovering from double pneumonia, the set-up sounds all right.

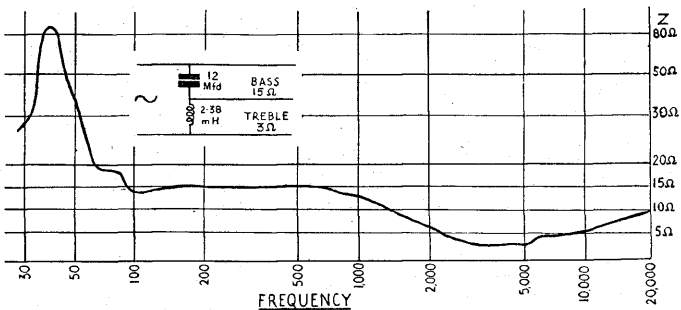

FIG. 45/11.—Impedance curve of 15 ohm and 3 ohm speakers with crossover N.W.4.

Circuit N.W.6. Half section, parallel, constant resistance. This arrangement gives very good results, and is cheaper to build than N.W.5. A careful listening test gave the impression that results were rather better than the quarter section type N.W.4. Attenuation and impedance curves now follow. Values of 8 Mfd and 3 mH would probably have been better for the units with which these curves were taken.

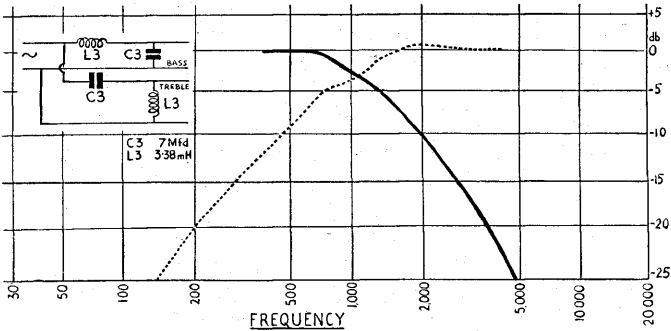

Fig. 45/12.—Attenuation curves with N.W.6 with two 15 ohm speakers.]

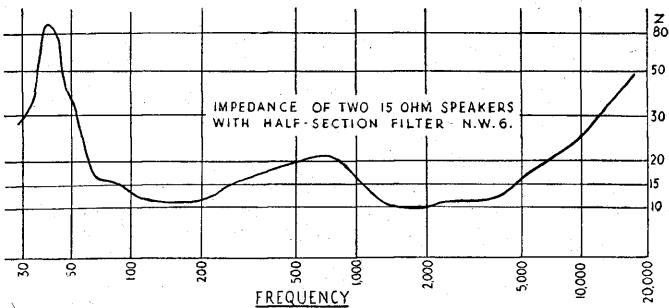

Fig. 45/13. — Impedance curve of two (nominal) 15 ohm speakers with crossover N.W.6.

Circuits N.W.7 and 8. Half section, filter types. Series and parallel. These differ from the previous constant resistance types in that different values of inductance and capacity are used in each limb. With this arrangement, the series type appears to give the best audible results.

CROSSOVER NETWORKS

Circuit N.W.9. Attenuation at 18 db per octave is not required under normal conditions, as there is no valid objection to a reasonable overlap between the two speakers. The loss of power amounting to 3 db introduced by this circuit would only be justified where a sharp cut-off is essential to avoid overloading a delicate speaker such as a Ribbon type.

Circuit N.W.10. Three loudspeakers. For the first test with three speakers we used a small horn-loaded unit with bakelite diaphragm as the third speaker, with .5 Mfd in series with the tweeter voice coil. The attenuation came out as follows :

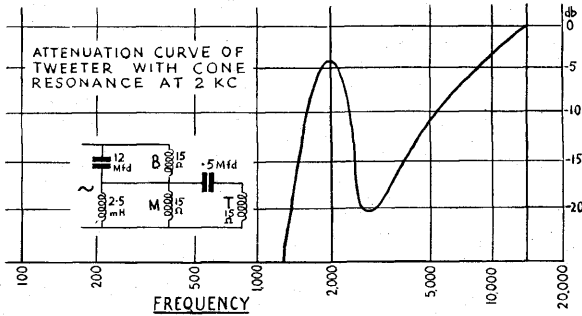

FIG. 45/14.—Output of third speaker with cone resonance at 2,000 c.p.s.

It was found that the cone resonance, which gave the speaker an impedance of over 30 ohms at 2,000 cycles, was breaking through the isolating condenser. Such a speaker would require a filter at 2 kc for satisfactory results as a third unit. Changing the third speaker to a special 8" unit (still with .5 Mfd in series) removed the 2 kc resonance completely, but introduced a circuit resonance at 10 kc which, however, was not strong enough to cause trouble. Although a resonance in the 10–15 kc section may be a useful H.F. boost, indications are that the effect of adding an extra loop to a crossover network needs watching. Excellent results were obtained with a Ribbon speaker for 5,000 cycles and upwards, with 4 Mfd isolating condenser.

GENERAL CONCLUSIONS

1. Do not use electrolytic condensers, as they require D.C. polarising voltage for maintenance of capacity, and possess a considerable resistive component resulting in power loss.

2. Air-cored coils, which may be wound on wood or bakelite, are suitable. They should be wound with thick copper wire, cotton covered. The D.C. resistance of such coils will not exceed the following values :

Inductance	Resistance
·5 mH	·25 ohm
1·5 "	·50 "
2·5 "	·65 "
3·5 "	·80 "
6·5 "	1·00 "

Coils with iron or dust-iron core would also be suitable in some cases.

3. The speakers may be connected either in phase or out of phase. It is always worth while to reverse the leads to one speaker and listen to the result. Note that speakers connected as in the following diagram are actually in phase.

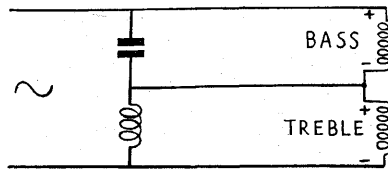

FIG. 45/15.—Speakers in phase.

The above remarks about phasing apply only to the separate bass and treble speakers. Where two or more bass units are used, they must of course be connected in phase to avoid severe loss of output from cancellation of sound waves. The same remarks would apply to two or more treble units, although losses at high frequencies would not be so severe.

4. An extension speaker connected in parallel with a crossover network upsets the response. Any volume control used in the network should be tapped choke in preference to the usual variable resistance type.

CROSSOVER FREQUENCY

There is some doubt in the minds of many listeners about the choice of crossover frequency for best results. Cinema equipment usually includes a massive and costly filter to work between 300 and 500 cycles, but it should be remembered that large power and big speakers are involved, the upper limit of response is about 8 kc, and the effects

of different path lengths in the speaker housings may be serious in a large auditorium. Domestic conditions are quite different. It does not follow that because a 500 cycle crossover costs twice as much as 1,000 cycle network it is twice as good.

As a general rule it is satisfactory to select a point somewhere between 500 and 1,000 cycles. As there is always some overlap between the speakers, it is impossible to cite a particular frequency as correct.

The use of a Ribbon unit as the treble speaker may lead to the adoption of a crossover between 2,000 and 5,000 cycles, which in turn may compel us to change our ideas about the whole problem. A good 15" loudspeaker can be designed to give very smooth and level response up to about 4,000 cycles. At the highest tolerable domestic volume level the writer can detect no intermodulation distortion in such a speaker with 9 cu.ft. of air loading. Further, the inside dimensions of a 9 cu.ft. enclosure are about 30" to 40", corresponding to wavelengths between 300 and 500 c.p.s., so the "boxiness" in the region above 1 kc, described in the chapter on Air-loading, will not occur. Resonances and standing wave effects below 1 kc may be subdued by felt lining if necessary. Extending the use of a first rate 15" speaker up to 4 kc therefore strikes the writer as fundamentally practical and economically sound.

Another interesting point arises in considering the crossover circuit in relation to the Ribbon. The low impedance means the use of a fairly big condenser, which lowers the frequency of the resonant circuit, and probably reduces its intensity. (See Chapter 10 on Ribbons for workable crossover values.)

DIFFERENT IMPEDANCES

It has already been pointed out that speakers of different impedance may be used with a Separator, provided the amplifier gives a low impedance source. Some adjustment of values in the network will improve results. For instance, in Circuit N.W.4, the condenser value should be increased when a 3 ohm treble speaker is used in a 15 ohm circuit. Similarly, the change to a 15 ohm bass speaker in a 3 ohm circuit should be accompanied by an increase in the value of the coil inductance.

IRON CORED COILS

It is usually said that iron cores should not be used in crossover networks, but as it is possible to produce them with very low resistance this may in some cases more than offset any disadvantage of using iron, particularly in low impedance circuits, or where it is important to avoid loss of power. There is always a possibility of slight distortion from the iron, and as the inductance rises with increase of voltage, the crossover would begin to work at a slightly lower frequency as the volume level is raised.

TONE CONTROL

The effect of different values of capacity and inductance on speaker response has been investigated and tabulated in this chapter to a greater extent than would be required simply for crossover networks. This has been done as a guide to those who may wish to include a measure of tone control in a loudspeaker circuit. For instance, a tapped choke could be used to give a nicely graded falling characteristic to balance the rising H.F. response of some modern recordings, where the existing amplifier controls do not quite meet the case.

CONE RESONANCE

Next to a prominent bass resonance at or above 80 cycles, the most annoying peaks in loudspeaker response mainly occur in the upper-middle register between 2,000 and 5,000 c.p.s. A crossover at about 4,000 cycles helps to subdue these resonances, often with astonishing success, because the power is divided between two speakers in the region of crossover.

In fact, a bout of intelligent juggling with component values may produce remarkable results. Suppose a 15-ohm treble unit suffers from this upper-middle complex, and a change from 1 Kc. to 4 Kc. crossover is adopted. The normal L. & C. values of 0.60 mH. and 2.5 Mfd. in a quarter section filter would give improved results. But all trace of upper-middle resonance could be eliminated by reducing the condenser value to 1.5 Mfd. and increasing the inductance to about 0.90 mH. Such attenuation of response in the region of previous peaks often removes the monotonous "wireless" coloration from reproduction and adds new character to the tone. To go a step further, if you now re-wind the voice coil with aluminium wire you might imagine that you were listening to a ribbon speaker, because you are actually approaching ribbon characteristics.

CROSSOVER DISTORTION

Some radio engineers claim that the quarter section filter introduces distortion which is avoided by the half section type. The writer is unable to understand how distortion is overcome by increasing the number of elements presumed to be the cause of the trouble. Coils and condensers inserted in a speaker circuit attenuate the response and waste power; they are used as a necessary evil.

CROSSOVER NETWORKS

It is a complete fallacy to assume that overlap between two or more speakers causes phase distortion in the sound waves in the listening room. If this were true, then all sound heard in any enclosed space would be distorted by phase effects from walls, which is absurd.

WINDING DATA

Using 18 s.w.g. cotton-covered enamelled copper wire on 1" diameter wood or bakelite former 2" long, the following inductance values are reached at 32 turns per layer :

125 turns	..	0.25 m.H.	328 turns	..	2.00 m.H.
175 "	..	0.50 "	340 "	..	2.20 "
240 "	..	1.00 "	390 "	..	3.00 "
255 "	..	1.20 "	400 "	..	3.20 "
285 "	..	1.50 "	450 "	..	4.40 "

Other values may be estimated.

Part 2

CHAPTER 19

RECORDING SYSTEMS

There are only three main systems of recording sound:

1. Mechanographic ;
2. Magnetic ;
3. Photographic.

The original invention in each case is now fifty or more years old.

In mechanographic recording, discs have been adopted for all purposes except dictation machines for office use, in which a cylinder is used to facilitate the process of shaving off and re-recording.

Magnetic recording has made rapid progress during the last three or four years, and is finding a wide market in those applications of sound reproduction for which it is eminently suitable. Experiments have already been made in replacing the normal sound track on films by a strip of metallic coating for magnetic recording to give immediate playback possibilities and to overcome the drawbacks of developing the photographic track and to avoid the effect of scratches on the quality of reproduction.

A comparison of the principal qualities of magnetic and disc recording is given in the following summary :

MAGNETIC RECORDING

DISC RECORDING

1. *Playing time for Response to 12 Kc.*

15 minutes per reel of 1,200 feet of tape.

40 minutes per record with microgroove.

2. *Monitoring*

Quality can be checked while the actual recording is in progress.

Replay required.

3. *Reproduction*

Reel can be replayed immediately after rewind, without affecting quality

Disc can be replayed before being processed, but a duplicate is cut for this purpose to avoid damage to original.

4. *Resonances*

No mechanical resonance from moving parts.

Care in design required to overcome resonances from cutters, needles, armatures, etc.

5. *Surface Noise*

Very low with good quality tape or wire, not increasing with reasonable use.

Lacquer disc—very low. Vinylite disc—low. Modern shellac disc—medium. Noise level increases with use in all cases.

6. *Permanence*

Recording easily removed. Essential for continuous use of medium: not so good for performances for re-sale.

Recording permanent. Essential for performing rights and sale of records.

7. *Economy*

Reels expensive but can be re-recorded any number of times.

Lacquer discs cheap, but can only be used once.

8. *Frequency response*

Correction required.

Some correction required, but not so much as in magnetic systems.

9. *Frequency Range*

Improving. At present 30-15,000 c.p.s. on available British tape.

Very good, 30-20,000 c.p.s. now possible.

10. *Playback of Excerpts*

Not convenient.

Quite easy.

11. *Sub-editing*

Cutting and joining tape or wire is a simple operation.

Similar patching not possible.

12. *Copies*

Production of duplicates not possible without re-recording.

Ideal for processing and production of pressings at low cost.

13. *Handling*

Inconvenient.

Very convenient.

14. *Storage*

Possibility of "printing through" and deterioration under extreme climatic conditions or after a number of years.

Master records may be stored indefinitely, under reasonable conditions.

It is clear that the two systems are complementary rather than interchangeable. The technicalities involved are considered in further chapters.

PHOTOGRAPHIC RECORDING

Recording on film appears to have been first thought of in 1900 by a physicist named Ruhmer. In 1907 a British Patent was granted to Eugene Lauste for "a new and improved method of and means for simultaneously recording and reproducing movements and sounds". The patent expired before it was worked, as Lauste was 20 years ahead of his time. It is related in Wood's "Physics of Music" that one of the patent attorneys of the Bell Telephone Laboratories came across a letter in the Press complaining that an old man, Eugene Lauste, who

had pioneered in the art of talking motion-pictures, was destitute while the industry prospered. The man was traced and became a member of the technical staff of Bell Telephone Laboratories.

There are two types of sound track in use to-day—variable area and variable density—each sub-divided into many different methods.

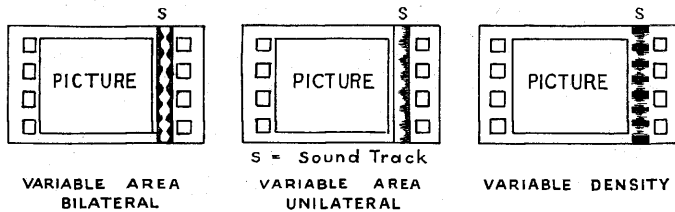

FIG. 46.—Types of Recording on Film.

In recording on film, the light passing through a slit varies in such a way that its changes correspond to the sound waves. Photographic systems do not enter into regular sound broadcasting on account of delay in developing and printing and the expense of the film, but it is used in television where the sound track needs to be synchronised with the picture track.

PHILIPS-MILLER SYSTEM

Although really a mecanographic system, this recording medium is a film coated with a layer of gelatine to which is applied a fine skin of black mercuric sulphide. It is used by the B.B.C. and the following description and illustration are taken from the article by Mr. Pulling previously mentioned.

A reel of film is about 10 inches in diameter, with a playing time of 15 minutes. The cutter makes hill-and-dale incursions in the gelatine layer, cutting away the opaque surface and exposing a transparent track down the centre of the film. The method of reproduction is by projecting a fine pencil of light through the film on to a photo-electric cell, similar to photographic systems. It has the advantage of constant track speed (12 inches per second) and is ready for reproduction as soon as it has been rewound. The recording can be reproduced many times without deterioration, but cannot be erased

RECORDING SYSTEMS

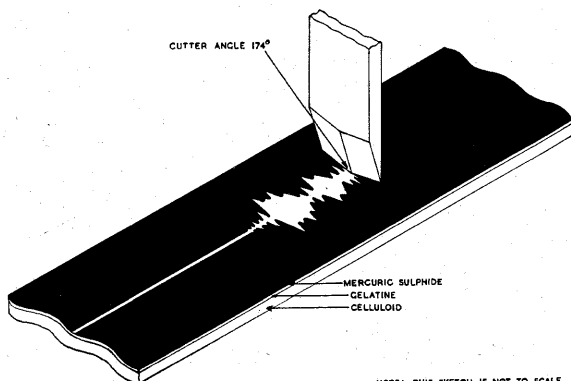

NOTE:- THIS SKETCH IS NOT TO SCALE

Reproduced from B.B.C. Quarterly.

FIG. 47.—Philips-Miller system: diagram showing sapphire cutter, a portion of film and specimen recorded track.

to enable the film to be used again. The system lends itself to the recording of two tracks side by side for stereophonic effects, and experiments along these lines have been conducted in Holland.

CHAPTER 20

MAGNETIC RECORDING

The first magnetic recorder was invented by Valdemar Poulsen in Copenhagen in 1899. Known as the "Telegraphone", his invention was intended for recording telephone messages automatically, as well as for use as a phonograph.

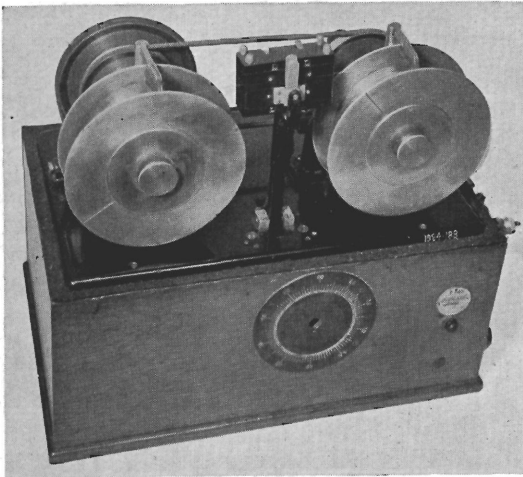

*Crown Copyright.
From an Exhibit in
Science Museum,
S. Kensington.*

FIG. 48. Poulsen's Telegraphone.

Poulsen described methods of magnetising wire, steel tape, or paper tape coated with metallic powder, all of which are being used to-day. The recording could be wiped off electrically and the tape or wire used over and over again. The system was later improved by Stille, and the Marconi-Stille machine employing steel tape was the first recording system to be used by the B.B.C., and is still in limited use, although the quality is not up to modern standards. The steel tape was wound on steel drums of 2 ft. diameter, weighing 11-12 lb. and running 30 minutes; rather unwieldy compared with later types.

Recent developments in magnetic recording with wire, or plastic tape containing finely divided magnetic particles, have resulted in

improved quality and lighter weight. The Magnetophon tape recorder produced in Germany, and the Armour Research Foundation wire recorder in America, were pioneers. In England the E.M.I. Tape Recorder was developed and sets a very high standard.

The growing interest in, and rapid development of, magnetic recording since World War II do not mean that tape or wire systems are likely to replace discs for home reproduction of music. Apart from the ease of handling and convenience of storing gramophone records, it is clear that few famous artistes would be willing to record in a medium which is so easily erased and re-recorded as magnetic tape, where the door would be left wide open for the machinations of the practical joker or other misguided individual. The ordinary gramophone record is at least permanent in this sense.

It would also be a mistake to assume that disc recording is being superseded on the score of frequency range and quality of reproduction. There are four main obstacles to perfection in tape recording, which may be summarised as follows :

1. Non-linearity of hysteresis loop in magnetic material.
2. Variation of voltage output with frequency.
3. High frequency losses from de-magnetisation by leakage flux as tape leaves gap of recording head.
4. De-magnetising effect of adjacent magnetic poles at short wavelengths.

There are, however, many uses for which magnetic recording is the ideal medium, and the remainder of this chapter is devoted to a brief outline of the principles involved and the methods generally employed to overcome defects.

The following books are recommended to those who may wish to go more deeply into the subject :

Elements of Sound Recording by J. G. FRAYNE and H. WOLFE. John Wiley & Sons, Inc., New York. Chapman & Hall, Ltd., London.

The Recording and Reproduction of Sound by OLIVER READ. Howard W. Sams & Co., Inc., Indianapolis.

Magnetic Recording by S. J. BEGUN, Murray Hill Books Inc., New York.

As the title implies, the book by S. J. Begun is devoted to all aspects of Magnetic Recording, with details of research and equipment by The Brush Development Company.

The book by Frayne and Wolfe ranks in relation to the *Elements of Sound Recording* with Olson's book on *Elements of Acoustical Engineering*. The Oliver Read book also contains much valuable information, with rather more emphasis on the practical side.

The following block diagram gives a general idea of the component parts of a typical magnetic recorder of high fidelity :

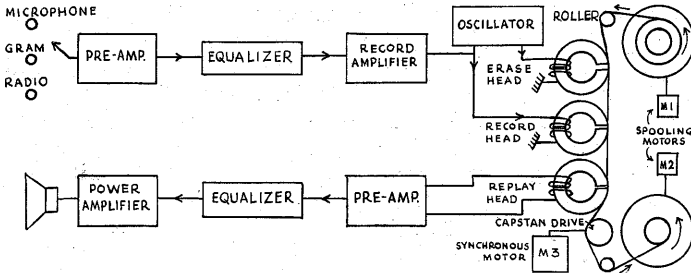

FIG. 48/1.—Block diagram of typical Tape Recorder.

In recording, the magnetic material, wire or tape, is drawn past the erase head to remove any trace of previous magnetisation, and then past the recording head where the signal in the coil is impressed on the tape in the form of magnetisation. For reproduction, the erase and record heads are switched off and the play-back head is brought into use, if not already in use for monitoring during recording.

The diagram shows separate heads for recording and replay, but in many machines one head is used for both purposes for reasons of economy, although it would be generally agreed that for maximum results it is a case where two heads are better than one. The diagram also shows three separate motors and two distinct amplifier circuits. Here again, considerable economies are possible. It will be appreciated that the capstan must run at a uniform speed, but the two spools will vary in speed according to the quantity of tape on each. The speed of the two spooling motors must be controlled accordingly. Where one motor is used to supply a common drive, the variation in speed of the spools is achieved by friction, which is adjusted to maintain a reasonable tension on the tape.

As regards the amplifiers, the recording head requires constant current conditions, calling for a high impedance source. On the other hand, a loudspeaker requires constant volts from a low impedance

source for best results. Nevertheless, by suitable switching of output circuits, one amplifier may be arranged to function for both record and replay, with an additional amplifier for extra power to the loudspeaker as required. The recording level is quite low, usually not more than 10–15 milliwatts, compared with 15–20 watts for disc recording.

RESPONSE

As usual, the extremities of the frequency range are the most difficult to record. The constant current characteristic of magnetic recording results in a voltage output from the replay head which gives a frequency response rising at about 6 db. per octave, peaking at a frequency which depends mainly on gap width and coercivity of recording medium. Beyond this peak there is a falling characteristic due to magnetic losses. Both record and playback amplifiers are usually fitted with response correction to equalise the output. Typical response curves of wire and tape are given in Fig. 48/2, the curves being drawn for equal output at 100 cycles.

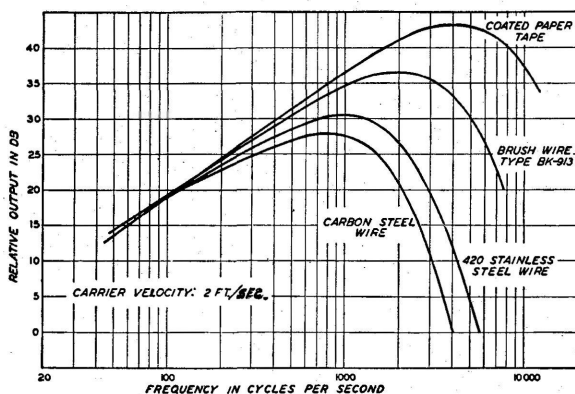

Courtesy
Brush Development
Company

FIG. 48/2.—Curves comparing frequency response of a coated-paper tape with various magnetic wires.

These curves indicate the superiority of tape, and also show the effect of the quality or coercivity of the wire at high frequencies.

Improved qualities of tape, with finer magnetic particles, also result in better H.F. response, as shown in the next diagram :

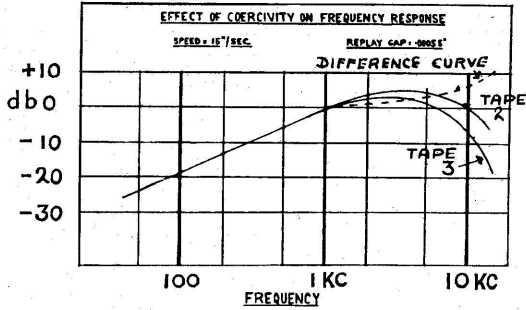

Courtesy E.M.I., Ltd.

FIG. 48/3.—Effect of coercivity on frequency response.

RECORDING HEAD

The following diagrams illustrate the various methods of magnetisation which have been used :

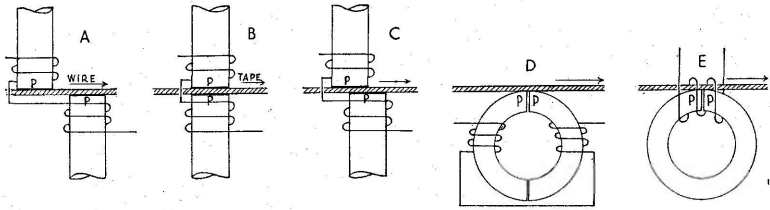

FIG. 48/4.—Various methods of magnetisation.

- A—Longitudinal.
- B—Perpendicular.
- C—Oblique.
- D—Open head
- E—Closed head

The longitudinal method A was the one originally used by Poulsen. The wire passes between the two pole pieces which are staggered so that magnetisation is induced in the wire in the direction of travel. All machines using wire as the recording medium must employ the longitudinal method of magnetisation, as the wire may rotate about its axis during replay, which would cause variation in output with other methods.

In method B, magnetisation is induced at right angles to the direction of travel, with improved H.F. response : it is not suitable for use with coated tape. Method C is similar at H.F., but gives longitudinal magnetisation at low frequencies.

The open head, type D, is the one generally adopted in this country. The core is made up of high permeability laminations such as permalloy, with low hysteresis loss. The gap is usually $\cdot 001''$ wide and may be formed by the insertion of beryllium copper shims between the pole faces, although a clean butt joint with a true air gap may be used. The tape passes over the head as closely as possible, so a smooth finish is essential. The hardness of the beryllium helps to protect the gap faces from wear.

In the closed head, type E, the coil surrounds the wire or tape as well as the pole pieces. It is claimed for this design that the effect of stray fields is reduced, thus minimising hum troubles : also that the response is improved on playback (with the same type of head) as the effect of leakage flux is reduced.

Heads may be wound with high impedance or low impedance coils. Usually, low impedance is preferred for recording, and high impedance for reproducing.

REPLAY HEAD

The gap should be as fine as possible. Practical considerations limit the design to a width of about $\cdot 0005''$. The following diagrams illustrate the effect of gap width on response at speeds of $7\frac{1}{2}''$ and $15''$ per second, with best quality tape.

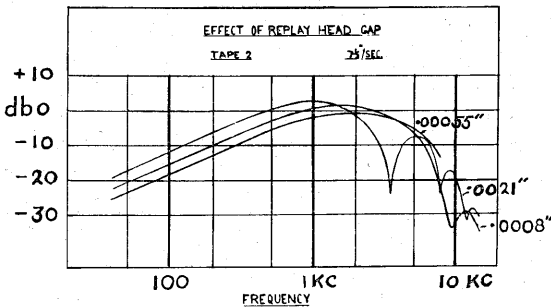

Courtesy E.M.I., Ltd.

FIG. 48/5.—Effect of Replay head gap at $7\frac{1}{2}''$ /sec.

It is common commercial practice today to use one head for record and replay, with a gap of the order of half to one thousandth of an inch.

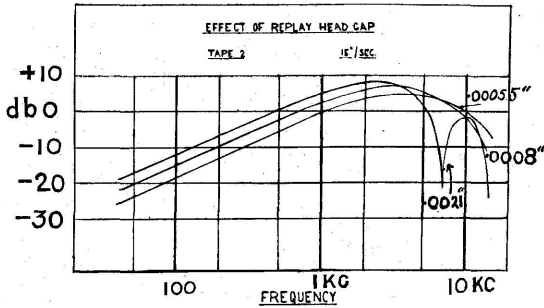

Courtesy E.M.I., Ltd.

FIG. 48/6.—Effect of Replay head gap at 15"/sec.

ERASE HEAD

Thorough erasure of the tape or wire is necessary before it passes over the recording head. This may be done by saturation with D.C. or a permanent magnet. The method usually adopted is by H.F. current from the bias oscillator, using a head with a wide gap ($\cdot 010''$ or $\cdot 020''$). The H.F. erasure stabilises the magnetic medium and results in lower background noise than the D.C. wipe.

A combined head for recording, reproducing and erasing has been designed by E.M.I. Ltd., and is suitable for use in a device with an endless loop of magnetic tape on which a recorded message is required to be repeated a large number of times, and the operations of erasing and re-recording are likely to be carried out only at infrequent intervals.

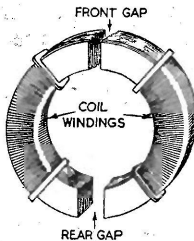

Courtesy E.M.I., Ltd.

FIG. 48/7.—Magnetic Transducing Head for recording, reproducing or erasing.

It will be seen from the illustration that the ring-shaped core has two diametrically opposed gaps, the widths being $\cdot 001''$ and $\cdot 010''$ respectively. For erasure, the tape may be lifted from the front to the rear of the head, or the head may be mounted to be rotatable through 180° .

GAPS

References in this chapter to the width, length and depth of a gap are in accordance with the following sketch :

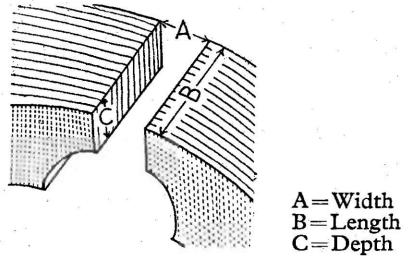

FIG. 48/8.—Gap of Magnetic Head.

The shortest dimension is referred to as the width, in accordance with common practice in this country. The same designation is used by the authors of *Elements of Sound Recording*, but it is noticed that Oliver Read in *Recording and Reproduction of Sound* refers to the shortest dimension as the gap length, and the list of Proposed N.A.B. Standards also includes "gap length" in the glossary of terms. In order to avoid confusion in similar cases, it would be a good thing if an agreed list of approved terms and standards could be issued in both America and Great Britain.

It has already been explained that the width of the gap is mainly determined by considerations of frequency response. The depth is also of great importance, as it affects the reluctance and inductance of the head. Performance is affected as gap depth is reduced by wear, the reluctance being increased and the inductance reduced. Wear leads at first to higher H.F. output, but excessive wear results in reduction of response and poor quality. Replacement heads are easily fitted. An average depth for a new recording head gap would be in the region of $\cdot 010''$.

SPEED

For any given replay gap, the H.F. response is directly affected by the running speed of the wire or tape. The original Poulsen machine worked with a very wide gap of about $\frac{1}{16}''$, which required a very high speed resulting in noisy running and frequent breakage of the wire, with rapid wear of the pole faces. Assuming a gap width of $\cdot 001''$ and a tape speed of 2" per second, the highest recordable frequency would be, in theory, 2,000 cycles. ($2,000 \times \cdot 001'' = 2''$ per second.)

The same gap with a speed of 10" per second and a perfect recording medium, would go up to 10 kc. The effect of speed on the response of the best E.M.I. tape is shown in Fig. 48/9.

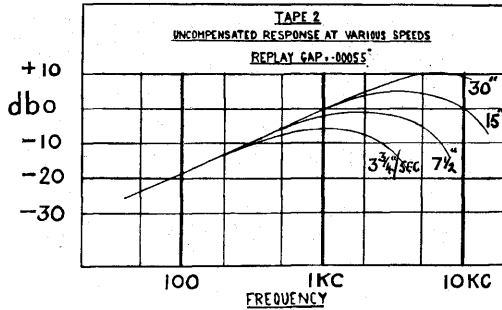

Courtesy E.M.I., Ltd.

FIG. 48/9.—Uncompensated response of E.M.I. Tape 2 at various speeds, with replay gap 0.00055".

Speeds of 30", 15", 7 1/2" or 3 3/4" per second are standardised, according to the response required and catered for in the rest of the equipment. Slower speeds obviously give longer playing time for a given size of spool, with a reduction of the rate of wear on magnetic heads. A playing time of 30 minutes per reel is usually found to be convenient. The following table gives the time for various sizes and speeds, with typical response ranges :

Tape speed	Response range c.p.s.	Spool size	Length of tape	Playing time
3 3/4"	100- 3,500	5"	600'	32 min.
7 1/2"	50- 7,000	7"	1,200'	32 "
15"	30-12,000	11"	3,250'	43 "
30"	30-15,000	11"	3,250'	21 1/2 "

The response ranges stated here are based on the best quality of tape available in England. The slowest speed would only be suitable for reproduction of speech, and the cheapest grade of tape would be the best economic proposition for the purpose. Low frequency response is not affected by tape speed.

NOISE LEVEL

The average background noise is very low in magnetic recording but is affected by the quality of the wire or tape. For best results, uniform diameter of wire is necessary, and tape must have uniform particle size of magnetic powder, even dispersion of the powder in the binder, and uniform stiffness and smoothness of the plastic base material.

WOW

All recording must be free from discernible wow for satisfactory results. There are two types which are liable to afflict the ear, viz., frequency wow and amplitude wow. Frequency wow is the result of periodic or random variations in speed which may be caused by eccentricity or faulty shape of capstan head or other rotating parts, irregularities of belt drive or gear teeth, or variations of friction in any part of the driving mechanism. A flywheel is usually coupled to the capstan to help in maintaining a uniform speed.

Amplitude wow is more likely to occur with magnetic recording than with ordinary disc recording. Such periodic or random variation of loudness is due to inequalities in diameter of wire or uneven density and thickness of magnetic particles in coated tape, and variation in mechanical contact between tape and replay head.

The ear is most sensitive to wow which occurs between 1 and 8 cycles per second. The effect is more noticeable on high notes than on low frequencies. A faulty gramophone turntable at 78 r.p.m. would produce wow at 1.3 cycles per second. The rate of wow at 33 r.p.m. with microgroove records would be .55 per second. With magnetic recording the rate of wow from faulty capstan would depend on rotation speed, which in turn depends on diameter of driving wheel and tape speed.

MAGNETISATION OF HEADS

The core of the head is usually assembled in two halves, with a separate winding on each, so that when brought together two gaps are formed. The rear gap serves to reduce remanence in the core, and to ensure that it does not become magnetically saturated. The coils are wound in a hum-bucking direction to reduce hum pick-up in the head from the motor, mains transformer or associated parts.

In spite of all precautions, the heads may become partially magnetised during use, with an increase in noise level. Some handy method of demagnetisation is advisable.

BIAS

It is essential to have some form of bias in order to limit the recording to a linear portion of the hysteresis loop. Without bias, reproduction of speech or music is badly distorted and is accompanied by constant spluttering. Reference to the next diagram, No. 48/10, will make this clear.

It will be seen that the waveform is distorted by the non-linearity of the remanence curve.

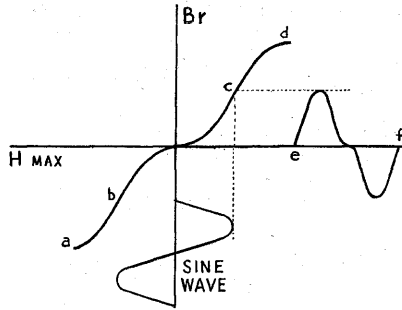

FIG. 48/10.—Typical remanence curve of magnetic material, with result on pure sine wave input.

One of the earliest methods of overcoming this distortion was the application of d.c. bias to bring the recording operation to a linear section of the curve around point *c* in Fig. 48/10. By limiting the level of modulation, an output of good quality could be obtained.

Improved methods of d.c. bias recording are illustrated in Fig. 48/11 and Fig. 48/12. In the first of these, d.c. bias is applied to bring the magnetic material to saturation, which also serves to erase any previous traces of recording. Low level output of good wave-form is obtained.

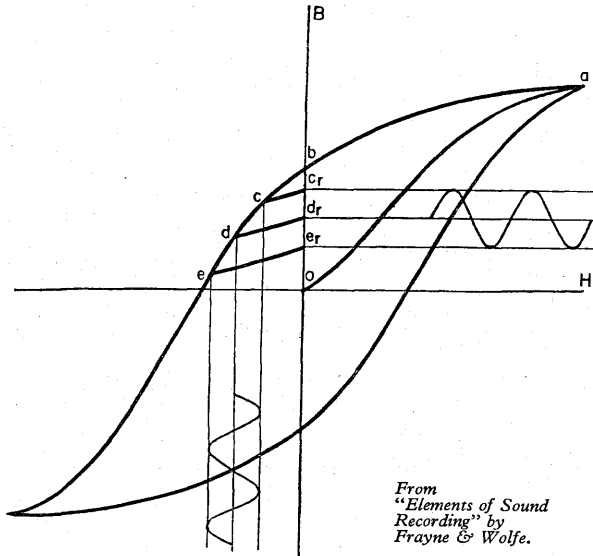
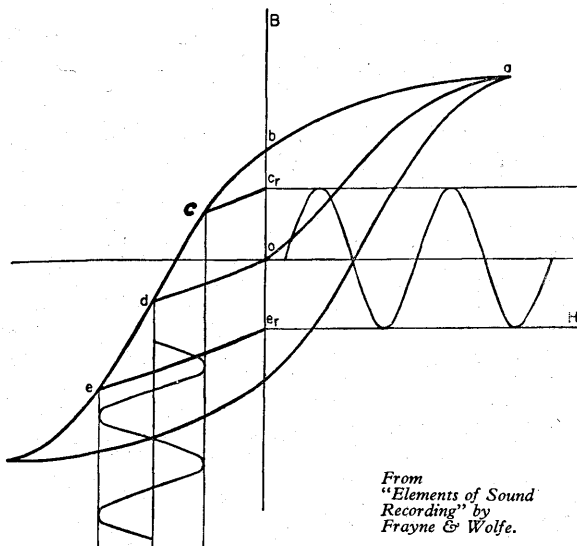

FIG. 48/11.—Curves illustrating the process of d.c. bias recording.

In the second method, Fig. 48/12, an increase of 6 db. in the output level is achieved, at some sacrifice of quality. Signal is applied about the point *d* of the hysteresis loop, and the iron is in a neutral magnetic condition during periods of zero input, resulting in the minimum of background noise during reproduction.



From
"Elements of Sound
Recording" by
Frayne & Wolfe.

FIG. 48/12.—D.c. bias recording in which the biasing field is so adjusted that the wire or tape is demagnetised during periods of zero signal input.

HIGH FREQUENCY BIAS

The use of this method of bias results in improved fidelity and higher output than the methods previously described. The theory is very complex and is far beyond the scope of this book. The frequency of the bias should be several times that of the highest recorded A.F. to avoid intermodulation. The combination of the A.F. signal and H.F. bias is outlined in Fig. 48/13. Comparison with Fig. 43 in the chapter on Intermodulation shows the difference between the modulated and unmodulated combination.

The three diagrams on Bias are reproduced, by permission, from *Elements of Sound Recording* by Frayne & Wolfe, published by John Wiley & Sons Inc., New York. All reproductions from other publications are also by kind permission of Authors and Publishers.

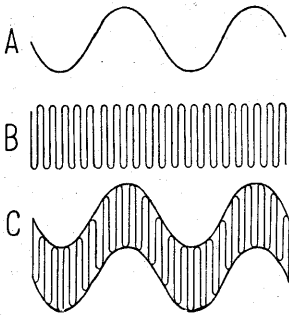
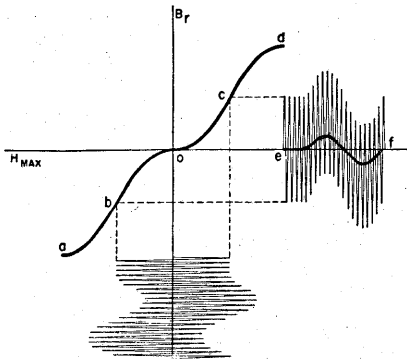

FIG. 48/13.—Application of H.F. bias.
 A—Audio signal
 B—H.F. bias
 C—Combination wave

Provided the wave-form of the high frequency is absolutely pure, and the optimum ratio between signal amplitude and bias amplitude is maintained, a recorded signal of low distortion will result, with high signal-to-noise ratio.

The next diagram gives a fairly clear picture of the application of H.F. bias and the resulting wave-form :



*From
 "Elements of
 Sound Recording" by
 Frayne & Wolfe.*

FIG. 48/14.—Curves illustrating the process of recording by means of H.F. bias.

The phenomenon is described by Messrs. Frayne and Wolfe in the following terms :

A very important factor in the recording process is the demagnetising force, which acts at the high frequencies and reduces greatly the amplitude of induction in the magnetic material after it leaves the recording gap. This effect is especially pronounced at the bias frequency.

After the medium leaves the gap demagnetisation takes place at bias frequency. A net induction then remains which is the difference between the positive and negative half-cycles of the bias wave, this difference being in turn a function of the audio signal. The remaining induction is shown by the curve of $e-f$ of Fig. 48/14. Where the audio signal is zero the medium is almost completely demagnetised, with the result that the noise level is low. Furthermore, if the bias amplitude is properly adjusted and the audio signal is not too large, the audio signal is transferred to the medium according to the linear portions b and c of the characteristic curve, with the additional result that the distortion is low.

Sometimes the same oscillator that supplies the bias current is also used to supply the erasing current; this arrangement has an advantage over two oscillators in that there is no possibility of beats and other undesirable interactions between bias and erase frequencies.

The current required for erasure is much higher than the bias current. The effect of correct bias current on frequency response is shown in Fig. 48/15.

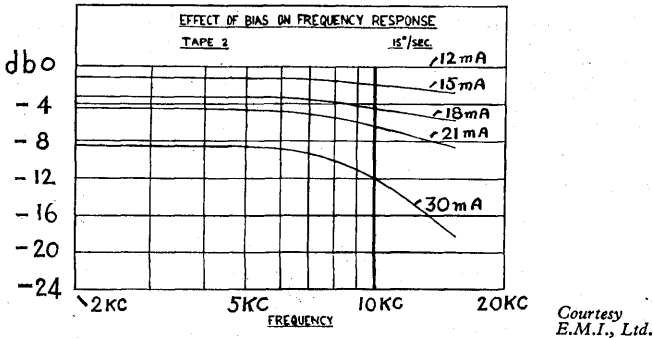

FIG. 48/15.—Effect of bias on frequency response.

DRIVE

The capstan head is made of non-magnetic material to avoid transmission of stray fields of hum. The diameter is made as small as possible in order to maintain a high rotation speed and reduce the incidence of frequency wow. A quick method of re-wind is essential for convenient use of equipment. Where three separate motors are used, a rapid re-wind is easily designed, with the tape running clear of heads. With a common drive, the empty spool may be screwed down to put the friction drive out of commission and the tape re-wound from the full reel.

DUAL TRACK

In order to double the playing time per reel, the recording can be limited to half the width of the tape. Machines employing this system are already being produced. The reduction of track width does not affect frequency response ; but the voltage output is less, so the signal-to-noise ratio suffers to some extent.



This chapter has been sandwiched into the book in order to give a description of magnetic recording which will be understood by the average non-technical reader. Let me admit frankly that in writing on the subject I am standing at the back and I do not even claim a seat in the stalls normally reserved for professional critics. I acknowledge gratefully the help received from the books already mentioned, from E.M.I. Ltd. in the shape of diagrams and information on their products, and also from Mr. F. Thistlethwaite, designer of the Excel Recorder, who has sub-edited the section and removed unwanted "ham" from the sandwich.

*Next o'er his books his eyes began to roll,
In pleasing memory of all he stole.*

POPE

A study of the technicalities of magnetic recording reveals that distortions and inequalities of response begin to crop up from the word "go". Fidelity of reproduction depends on overcoming these difficulties—not on designing amplifiers with level response. It is small wonder, therefore, that in acoustics, where measurements of performance are much more difficult to make, the most successful runner is still likely to be Harmony out of Trial and Error.

The following illustrations of commercial equipment are included as a matter of general interest. The E.M.I. Recorder is used by the B.B.C., and numbers have been shipped to countries all over the world. Broadcasting concerns usually install at least two instruments to enable continuous recordings of any duration to be made. The other two examples have been selected simply because the designer in each case happens to be known personally to the writer, who has watched the evolution of the instruments with some interest.

Magnetic tape recordings are now often used for cinema work, to be later transferred to film when scenes are completed. The advantages of immediate playback (and erasure when necessary) are obvious.

Many recording companies also use high quality tape for master recordings in order to have the facility of playback without deterioration, plus the benefit of monitoring during the actual recording.

It is not necessary to outline the many other uses to which magnetic recorders can be applied. Although tape gives the widest response, there are purposes for which the long playing time and compact size of machines using wire are ideally suited.

Most large firms associated with radio or cinema production have instruments either on the market, on the stocks, or on the hush-hush list. We are still a little behind the U.S.A. as a result of a longer wartime hiatus.



FIG. 49—E.M.I. Tape Recorder. View of tape driving mechanism, head assembly and control panel.

The frequency range is flat within 2 db. from 30 to 10,000 cycles, and a dynamic range of 60 db is claimed. A spool contains 3,250 ft. and weighs 1 lb., plays for 21 minutes at a running speed of 77 centimetres per second (30 in./sec.), and costs £3 5s. od. The tape is $\frac{1}{4}$ " wide and only 0.002" thick. The price of the machine complete is £550.

H.F. bias frequency is 100 Kc.



Courtesy Excel Services, 49 Bradford Road, Shipley, Yorks.

FIG. 50/1.—Tape Recorder for use with sub-standard ciné projectors.

This interesting machine is designed for coupling to a sub-standard silent film ciné projector, but is also usable as a separate recorder. The price complete with synchronising unit is about £70. The capstan speed is 120 r.p.m. to tie up with top or bottom sprocket of a projector. Normal tape speed is 12"/sec., so that one reel of 1,000' of tape will equal one 400' reel of 9.5 or 16 m.m. film, about 17 minutes run. Interchangeable capstan heads are available for tape speeds of $3\frac{3}{4}$ ", $7\frac{1}{2}$ " or 15"/sec. For cinema use, an ingenious superimposing device automatically subdues an existing recording of music during the application of a spoken commentary. H.F. bias and erase head are at 45 Kc. $\frac{1}{4}$ " plastic tape is used, with a frequency range of 50 to 9,000 c.p.s. at 12" per second. The slow speed of the capstan is balanced by a flywheel weighing 7 lbs.

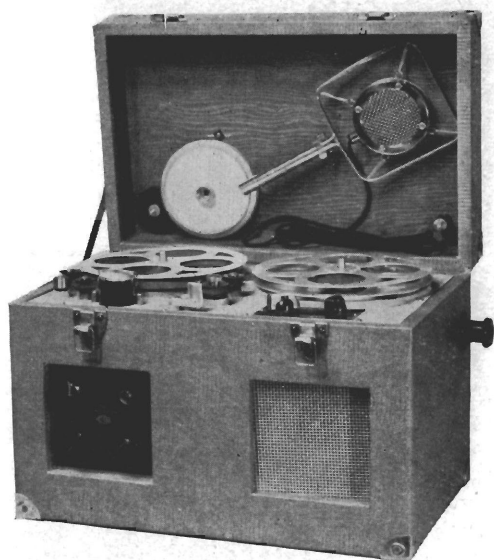

Courtesy G.L. Products, Ltd., 294 Broadway, Bexleyheath, Kent.

FIG. 50/2.—The Sound Magnet, Tape Recorder.

This is a complete recording and reproducing machine which sells at the modest price of £50. The usual $\frac{1}{4}$ " plastic tape is used. Speeds of $3\frac{3}{4}$ ", $7\frac{1}{2}$ " and 15 " /sec. are available, and a frequency range of 50 to 9,000 cycles is claimed at the highest speed. It is hoped to extend the range to 12 Kc. as improved tape becomes available. H.F. bias at $35/40$ Kc. Permanent magnet erasure. Dual track recording.

CHAPTER 21

DISC RECORDING

In spite of its basic fault of continual linear change of speed of groove, the disc has held its place as the most convenient and economical form of recording yet devised. This is not the result of some sinister plot on the part of big business; it is due to the inherent advantages of the system and the low price at which really good records can be produced in large numbers. Indications are that developments to lengthen the playing time per disc will bring the system another jump ahead of its rivals.

THE EARLY PHONOGRAPH

The invention of the Phonograph is attributed to Edison in the year 1877, although the French physicist Charles Cros communicated a similar idea to the Academie des Sciences in the same year. Edison appears to have attached scant importance to his invention at the time, as little more was heard of it for ten years.

The "Musical Times", of November, 1887¹, reported that Mr. Edison was again busy with his discarded toy. The instrument had appeared at the Crystal Palace as a nine days' wonder but had since been practically forgotten.

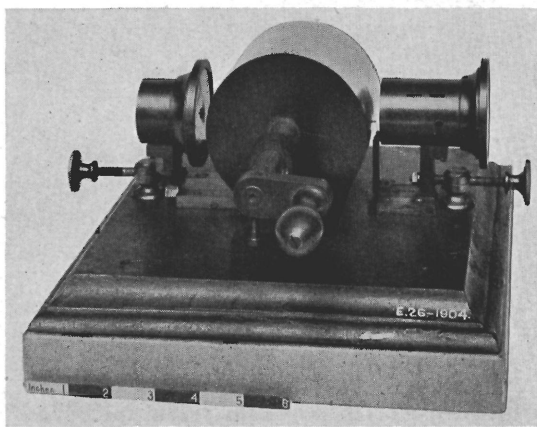

*Crown Copyright.
From an Exhibit in
Science Museum,
S. Kensington.*

FIG 51.—Early Edison Phonograph.

Ten years later, November, 1898, the "Musical Times" again refers to the invention, which it describes as "that wonderful instrument. The tone qualities of various musical instruments are reproduced with remarkable fidelity . . . There is naturally a ventriloquistic

¹ From "Oxford Companion to Music" (Scholes).

DISC RECORDING

character about the reproductions . . . a wonderful invention whose use will give much pleasure and not a little amusement. The cost is 6 guineas, plus fifty shillings for a large metal bell which amplifies the sound and effectively disperses it in a large room”.

BERLINER DISC

About 1888, another American, Emile Berliner (of German origin), obtained patents for several improvements, and replaced the cylinder by a disc revolving on a turntable, later using a shellac mixture for the production of records.



*Crown Copyright.
From an Exhibit in
Science Museum,
S. Kensington.*

FIG. 52.—Berliner Gramophone.

So the gramophone as we know it may be said to have originated in 1888. Rubber tubes fitted with ear pieces could be used in place of the horn. Ten years later a spring-driven machine appeared, fitted with a large horn ending in a flare.

In the early Edison model a membrane which closed the narrow end of a conical funnel was fitted with a chisel which indented the coating of the cylinder, thus giving a sort of hill-and-dale recording. As the handle was turned, a screw caused the cylinder to move along its axis as well as to rotate, and the turning speed controlled the pitch of the reproduced speech or music.

In the Berliner disc, the vibrations were lateral or side to side across the groove as used to-day.

SOUNDBOX

Improvements were constantly made, until the mechanical gramophone arrived at its final form with an exponential horn and carefully designed soundbox with a frequency range of about 150 to 4,000 cycles.

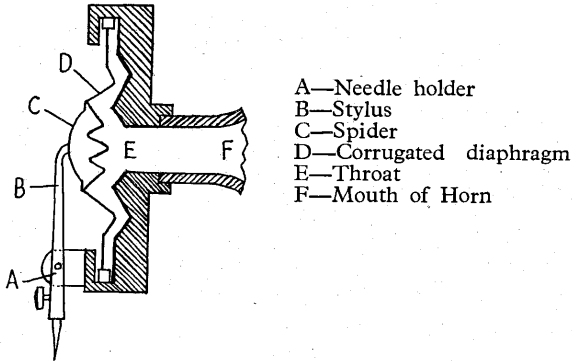

FIG. 53.—Mechanical Soundbox.

Sound energy was increased by the pressure chamber in the throat, and the following curves give a comparison of the response with the range of an average electrical system of to-day.

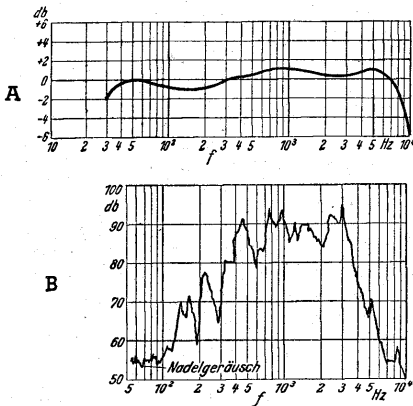

FIG. 54.—A. Response of average electric pick-up system.
 B. Response of Mechanical Soundbox.

From *Elektroakustisches Taschenbuch*.
 G. Neumann & Co.

EXPONENTIAL HORNS

Bass response was considerably improved in 1925 by the introduction of logarithmic horns, and in 1927 the H.M.V. re-entrant gramophone made its appearance.

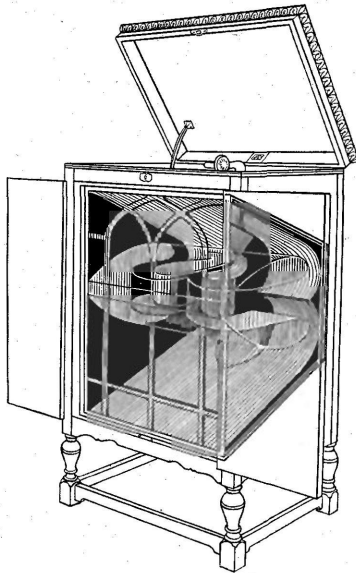

FIG. 55.—Re-entrant Exponential Gramophone.

Courtesy E.M.I. Ltd.

This was probably the first example of a folded horn based on the electrical principle of matched impedance.

EARLY RECORDING

The “ventriloquistic” effect of mechanical gramophones was largely due to resonances in the middle register which prevailed in recording equipment as well as soundboxes. Prior to 1924, all recording was done by acoustical methods. The sound was collected by a large horn, in the mouth of which the soloist had to perform and make some use of his lungs, so that up to the early '20s the curse of crooning had not begun to destroy the appreciation of good singing in a large section of the rising generation. Two interesting photographs of acoustic recording in actual session are reproduced . . .

Note the tape wrapping around the horn, applied to reduce resonance, and the spare horn with extra wrapping to cope with strong voices or resonant peaks.



*Courtesy
The Gramophone Co., Ltd.*

FIG. 55/1.—George Formby Senior making a record, with Tetrazzini as interested spectator.



*Courtesy
The Gramophone Co., Ltd.*

FIG. 55/2.—Sir Harry Lauder recording with orchestra.

DISC RECORDING

In the second picture the instrumentalists are placed so that the strongest sounds do not find their way directly into the mouth of the horn.

ELECTRICAL RECORDING

Round about 1924, microphone technique which had been developed for radio was applied to recording, and resulted in much wider frequency range, with better quality free from many of the pronounced resonances of the previous system.

The electric pick-up also made possible the use of much lighter moving parts. Resonances were moved up to less objectionable frequencies, and although somewhat crude when judged from modern standards, the early pick-ups enabled the user to appreciate the improvements brought about by electric recording.

COMMERCIAL RECORDS

The majority of commercial records are still made of shellac, with other ingredients to facilitate pressing and produce a durable article. The surface noise is affected by the quantity and quality of the fillers used, and upon the extremely fine polished surface of the matrix which should mould the material to give a good replica.

A lower surface noise occurs with Vinylite. Pressings for the B.B.C. and American Microgroove records are made in this material. The comparative noise level of different types of disc is as follows:—

Old shellac	..	—10 db
New shellac	..	—20 db
Vinylite	..	—30/40 db
Lacquer	..	—50 db

The noise level of shellac records can also be brought down to —30/40 db by the use of superfine fillers.

A large Vinylite disc of 16" or more diameter is quite flexible and lies flat when clamped down to a turntable dished $\frac{1}{8}$ " towards the middle. The risk of breakage is reduced and trouble from warped records is avoided.

Research in the application of plastics to record manufacture is constantly in hand.

VINYLLITE

As regards vinylite, it would be a mistake to assume that it has no drawbacks when used for gramophone records. Unlike shellac, vinylite records do not set hard, but retain a coefficient of elasticity which allows the groove walls to be pushed back by the stylus, thus affecting slightly the brilliance of the reproduction. Records are, however, being produced by Decca with a vinylite base, but with improved "setting" qualities giving greater resistance to wear. A remarkable photomicrograph of one of these records after 300 playings will be found in Chapter 32 on microgroove recording.

There are also indications that improved surface conditions are being produced on American vinylite discs. Two further photographs in the Microgroove chapter show an early pressing in comparison with a recent Columbia record. The difference is phenomenal.

Another disadvantage with vinylite discs is that they easily become electrostatically charged, and cleaning presents quite a problem. The presence of fine particles of dust in the grooves produces a background noise which is at times very prominent.

DUST

One of the quickest ways of removing dust from a record is to blow it off with compressed air. A pressure of 50 lbs. or more per square inch is required for effective cleaning. A visit to the local garage may result in a marked improvement to the background noise in reproduction.

A useful method of final cleaning is to take a velvet pad, breathe on it and wipe it immediately on a cloth surface to remove all particles of dust. Then breathe on the surface of the record and wipe with pad, again cleaning the pad on a cloth surface. These operations should be repeated until the whole surface of the disc has been treated.

The necessity of keeping all records free from dust and grit hardly needs pointing out, but it is important to remember that as groove and needle diameters are reduced and wave-lengths are shortened by slower speeds, so does the relative importance of particles of dust increase, producing more serious background noise.

The following untouched photograph of a dusty record gives a general idea of the actual size of particles of dust.

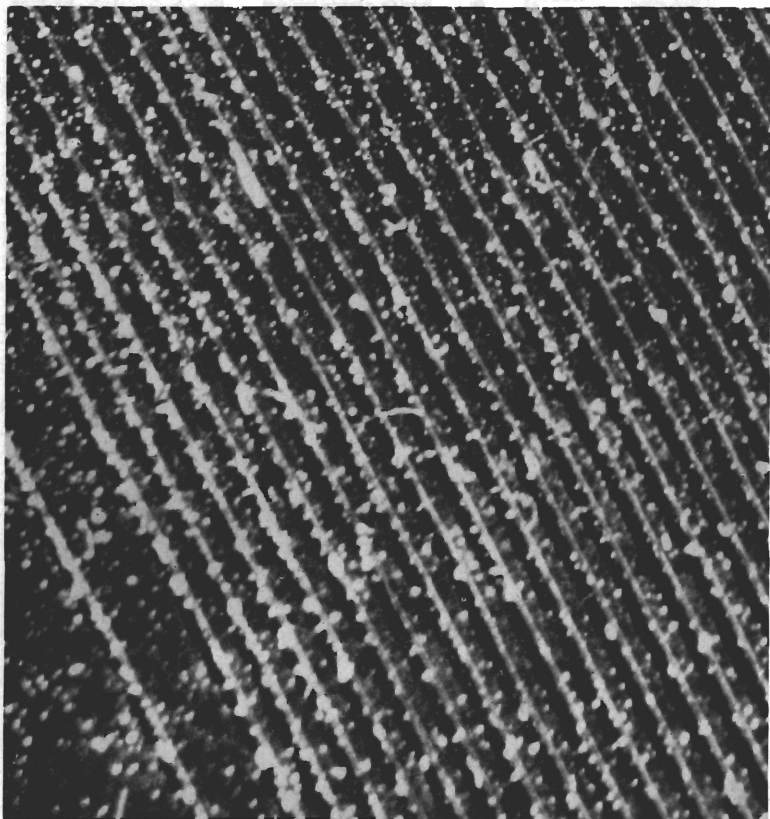

FIG. 55/3.—Enlarged photograph of dusty record.

The width of a groove is approximately $.006''$. The specks of dust are quite big enough to cause noise, and the average frequency of the noise will obviously be about an octave lower with the slow speed of microgroove records than with 78 r.p.m.

RECORD PROCESSING

The sequence of record manufacture is as follows :—

- | POSITIVE | NEGATIVE |
|----------------------------|-------------------|
| 1. Wax or Lacquer original | 2. Master |
| 3. Mother | 4. Working Matrix |
| 5. Record | |

The Master is "grown" on to the original wax or lacquer by several hours of copper plating. The Mother is then produced from the Master in a similar way, so that the Master may be stored away and used at some future date in case of damage to the Mother.

The actual pressing is done by the Working Matrices, which can be produced from the Mother as often as required.

In view of the complicated processes involved in recording musical works free from artistic and mechanical faults, the modern gramophone record represents a very high standard of organisation and workmanship.

The frequency range certainly extends up to 14 Kc/s., and in some cases even higher, compared with a pre-war limit of about 6,000 cycles. This does not mean that all pre-war recordings are sub-standard, as there were many excellent results which are in some cases preferred to later recordings of the same work.

CHAPTER 22

RECORDING CHARACTERISTICS

In order to obtain the best results from a record it is necessary to have some idea of the recording characteristics, so that the reproducing characteristic can be adjusted to balance. Unfortunately, recording characteristics vary according to when and where the record was made, and a good deal of flexibility is required in the reproducing equipment to do justice to a miscellaneous collection.

The general idea is to reduce the amplitude at low frequencies to avoid one groove cutting into the next, and to increase the power at high frequencies in order to improve the signal to noise ratio, but this method is by no means universally adopted to a uniform degree. It is not proposed here to discuss the merits of different characteristics. All we need to do is to find out what they are so that we may meet them intelligently and adjust our equipment accordingly.

The movement of the cutting stylus is analogous to the metronome in which the velocity of movement remains constant but the angle swept out increases as the frequency is lowered.

The present system adopted by Decca is a drop of 6 db per octave below 250 cycles, and a rise of 3 db per octave above 3,000 cycles, as in the following diagram.

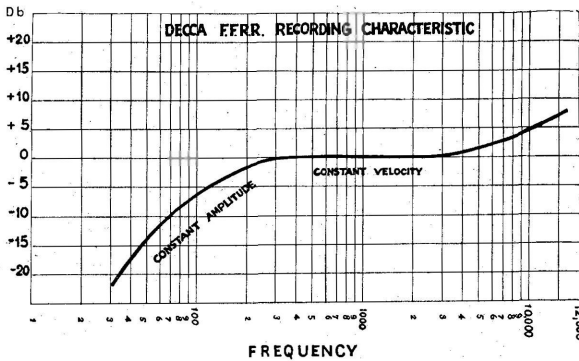

Courtesy Decca Record Co. Ltd.

FIG. 56.—Decca (England) recording characteristic.

Reproducing equipment for such records must, therefore, give a rise of 6 db per octave below 250 cycles, and a falling characteristic of 3 db per octave above 3,000 cycles. Note that pre-war Decca records did not have the same rising response in the treble, and therefore would not require the same H.F. attenuation in reproduction.

Turning now to E.M.I. (H.M.V., Columbia, etc.) we find the same low frequency attenuation at 6 db per octave below 250 cycles, but the level above this crossover frequency remains substantially flat all the way to final cut-off. This means that such records would not require the same amount of tone control as the previous type. It does not mean that the ultimate high frequency response must be inferior because the question of H.F. distortion is also involved.

If we now turn to the B.B.C. and America, we find further differences which it is worth while to examine.

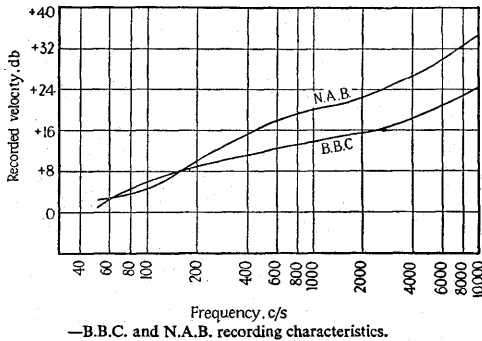

From I.E.E. Journal, July 1947. H. Davies

FIG. 57.

In explaining the B.B.C. characteristic curve, Mr. Davies states :—
 “If, with a given recording characteristic, the amplifier gain is continuously increased, a point will be reached beyond which distortion becomes unacceptable . . . Background noise will be minimized, however, by recording at as high a level as possible at all frequencies, and it follows that the best signal/noise ratio, with a given signal, is obtained by choosing the recording characteristic so that, on increasing the recording level, the limit of permissible distortion is reached simultaneously at all frequencies . . . In practice it is necessary to consider not only the distribution of energy in the programme but also the effect of radius compensation.”

The writer appreciates that the recording technique adopted by the B.B.C. does not concern the listener, as correction is applied to B.B.C. recordings before transmission by radio, but the similarity between the B.B.C. and N.A.B. characteristics is so strong that an explanation of one helps in the understanding of the other.

N.A.B.=National Association of Broadcasters, America.

AMERICAN RECORDING

It will be clear that if N.A.B. types of recording are reproduced on equipment with a response characteristic set for British recordings, the results will be unsatisfactory, thus accounting for a good deal of unfair criticism which is made in this country about American records. Under these conditions, American recording sounds shrill and short of bass, and no serious record criticism should be undertaken without making certain that the characteristics have been reasonably equalised. In the same way, when British records are played on equipment set to balance American characteristics, they give out plenty of bass with a falling high frequency response—a condition which is still very popular with many people.

MICROGROOVE CHARACTERISTICS

The amplitude of low frequencies in microgroove records is reduced to suit the narrow, closely placed grooves, the change from constant velocity to constant amplitude taking place at about 500 cycles instead of the usual 250/300 cycles. A typical curve of microgroove characteristics will be found in Chapter 32.

TRACK RADIUS AND RESPONSE

The use of light-weight small inertia pick-ups with sapphire points of correct shape has greatly reduced the loss of high note response at narrow track diameter, and has also decreased the overall tracing distortion. The following graph gives an indication of the drop in response at different frequencies towards the inner grooves of the record.

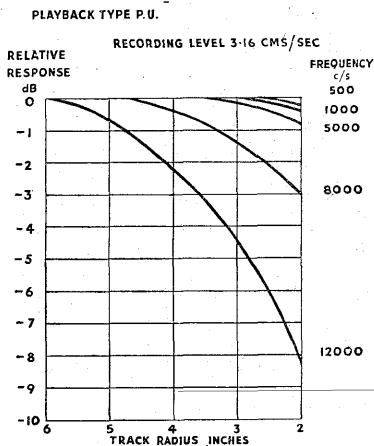

FIG. 58A.—Graph showing relative response at various frequencies at different groove diameters.

Courtesy E.M.I. (Paper by G. F. Dutton.)

With a constant recording level, the loss at 4 inches diameter is 8 db at 12,000 cycles. As the surface speed is down to about 16 inches per second, this loss is not excessive compared with other recording systems.

RADIUS COMPENSATION

In order to reduce the loss of high frequency response which occurs towards the centre of a record, the response of the recording amplifier is varied during the process of recording. The extent to which this is done by the B.B.C. is illustrated in Fig. 58B.

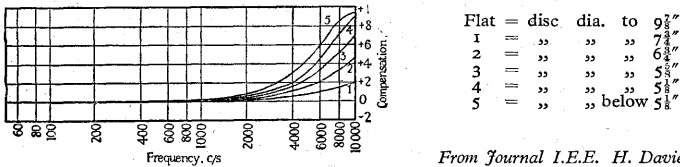

From Journal I.E.E. H. Davies.

FIG. 58B.—Radius compensation, 78 r.p.m.

As a result of this radius compensation, the recorded level of the higher frequencies is increased progressively as the cutter approaches the centre of the disc and, since this makes the curvature of the short waveforms even more acute, it further increases the amplitude distortion. The amount of compensation used is therefore a compromise between distortion and frequency response. It does not follow that the inevitable results of slower surface speed can be overcome completely.

Incidentally, it was pointed out by Mr. Mittell, of E.M.I., in his lecture to the Institute of Electrical Engineers, that 25 per cent of likely buyers of records in the U.K. to-day have acoustic gramophones, and in overseas markets, apart from America, the proportion is nearer 75 per cent. The recording characteristic advocated by Mr. Mittell is one considered to be most universally satisfactory, taking into account the above rather remarkable facts.

AMPLIFIERS

As it is not intended to give circuits or diagrams of amplifiers in this book, the most suitable place in which to refer to them is in the chapter on recording characteristics. The main function of the amplifying equipment, after living up to its name, is to correct the response characteristics of the remainder of the reproducing network. This network usually consists of six variable and often uncertain elements :—

1. Recording characteristic
2. Pick-up „
3. Radio tuning „
4. Loudspeaker „

RECORDING CHARACTERISTICS

5. Listening room characteristic
6. Volume level of reproduction

The radio tuning characteristic is often the opposite of recording, calling for bass cut on speech to improve clarity and H.F. increase to make up for tuning losses.

Maximum flexibility in the amplifier response is therefore essential. So-called straight line response is of no more use than a one-speed motor car. A good car is one in which you can vary the speed without discomfort up to reasonable limits of safety. A good amplifier is one in which you can vary the response without distortion up to reasonable limits of hearing. The important words are "without distortion". A wide-range, powerful amplifier with a high distortion factor is useless.

A three-channel design, giving independent control of extreme treble and extreme bass (without resonant circuits) is definitely indicated. If you have plus or minus 6 db per octave below 300 cycles and plus or minus 3 db per octave above 3,000 cycles, or something similar, you will cease to worry unduly about the response of the remainder of your equipment, and you will be able to do justice to a varied collection of records—including American types with their magnificent orchestras.

NEGATIVE FEEDBACK

The possibility of running into trouble with negative feedback on wide-range equipment has already been pointed out in several quarters. At very high frequencies there is the danger of a resonant circuit from the leakage inductance and self-capacitance of the output transformer which may even result in positive feedback, with disastrous results on quality. To overcome the trouble, which may occur at frequencies as high as 20,000 or 30,000 cycles, some degree of frequency control or extremely low leakage inductance is necessary.

There is also risk of trouble at very low frequencies, say below 40 cycles, from reactance of condensers and from saturation of the transformer causing iron distortion. These conditions lead to phase shift which could result in positive feedback, and steps should be taken to control the response in the 20-30 cycle region, especially when a loudspeaker is installed which really responds to these low frequencies.

If the foregoing premises are accepted, the ideal response range of the amplifier would be along the lines of the following maximum and minimum curves (Fig. 58C).

INVERSE DISTORTION

Distortion in amplifiers usually increases with volume, but in some cases, where the main volume control is located in the feedback loop, distortion arises at very low volume levels, owing to severe variation in the amount of feedback, particularly with frequency.

It is preferable to place the volume control in front of the feedback loop, but usually feedback can conveniently be effected without distortion by injection of the feedback voltage either into a cathode or into a screen-grid circuit.

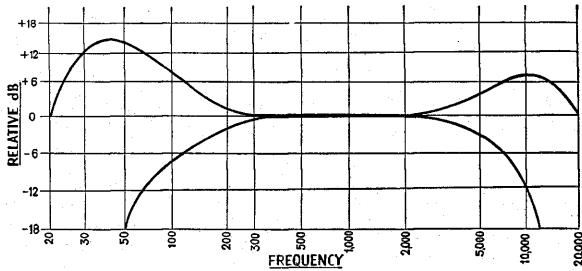

FIG. 58C.—Suggested MAX. and MINIMUM ranges for Amplifier (with negative feedback) for best reproduction of radio and records

The foregoing remarks on feedback and instability in amplifiers are only intended to apply to equipment which is produced under domestic or quasi-domestic conditions. The writer believes that the construction (as well as the design) of wide-range amplifiers calls for skill and experience backed up by adequate testing equipment. The mere assembly of parts to a given design does not guarantee results.

High-class amplifiers at a reasonable price, guaranteed free from distortion beyond a negligible amount, are now on the market, and give superb results.

MICROGROOVE REPRODUCTION

Since the main part of this chapter was written, I have been able to test several American microgroove recordings on British reproducing equipment. When the response is equalised, the quality surpasses expectations, and the long-playing provides a novel experience.

Unfortunately, with some amplifiers it is impossible to equalise the response, with the result that the L.P. records sound shrill. It is regrettable that, hitherto, uniform recording characteristics have not been standardised on both sides of the Atlantic. I am informed by Decca that the recording characteristic of their "London" microgroove records is generally similar to that used by the American recording companies, which calls for a falling response in reproduction at about 3 db per octave over the full frequency range. This means that the response range suggested in Fig. 58C would not be quite suitable for microgroove records; the level portion between 300 and 2,000 cycles

should be replaced by a continuous drop in response. A method of tone control in the loudspeaker circuit is suggested at the end of Chapter 32.

BUCHMANN-MEYER EFFECT

The response level of a constant frequency record is easily determined by the optical method named after Buchmann and Meyer, who first applied the principle. When a single source of light is reflected by the cut groove, the width of the luminous band is proportional to the velocity/amplitude of the curve. It is only necessary to hold a constant frequency record so that the light shines across it, to expose the recording level in the band width. Figure 58D shows the E.M.I. 78 r.p.m. recording characteristic, with the usual attenuation at 6 db per octave below 250 cycles.

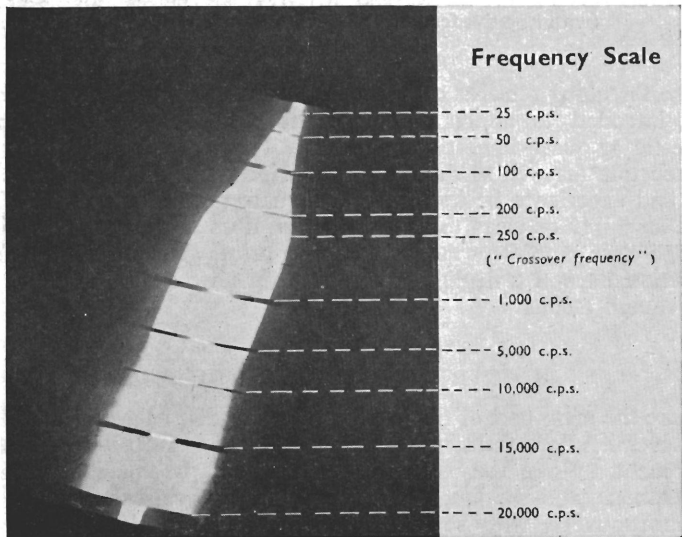

FIG. 58D.—Buchmann-Meyer pattern of E.M.I. recording between 25 and 20,000 c.p.s.

It is customary for engineers to keep a daily check on response of recording equipment by this method of inspection. The narrow band of light down the centre represents the surface noise of the unmodulated groove.

The next illustration, Fig. 58E, is a photograph of a direct recording by Mr. A. R. Sugden of Brighthouse, using a moving-coil cutter head with constant voltage applied. The pattern shows the general response of the system in conjunction with the filter correction box.

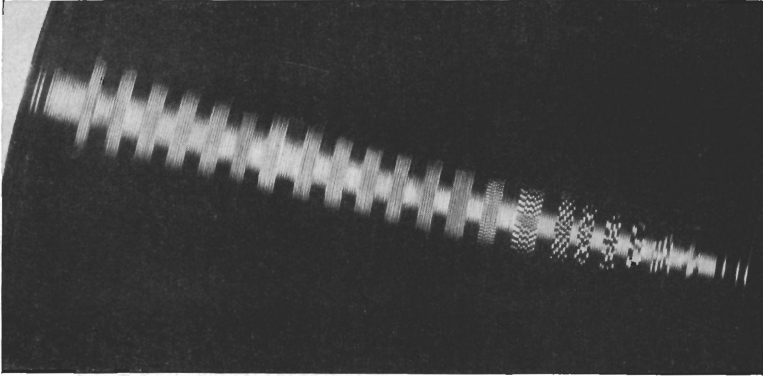

FIG. 58E.—Photograph of recording of frequencies from 15 Kc. to 50 c.p.s. at 78 r.p.m.

Starting from the outside of the disc, the frequency bands are as follows :

15 Kc. down to 1 Kc. in steps of 1 Kc., then 500, 400, 300, 200, 100 and 50 c.p.s. The slightly lower recording level below 300 cycles is due to the characteristics of the cutter head.

As this is an untouched photograph, actual size, it is possible to check some of the recorded frequencies by counting the number of waves per inch. The easiest band to see is the 1,000 cycle section. This is No. 7 from the inside or No. 15 counting from the outside of the disc. There are 8 indentations in $\frac{1}{4}$ " making 32 per inch, which equals $\cdot 0312$ " each. The recording diameter is about $7\frac{1}{2}$ ", say 30 " / sec. surface speed. Reference to Fig. 64 gives the wavelength of 1,000 cycles at 30 " / sec. as $\cdot 030$ ". Q.E.D.

CHAPTER 23

DIRECT RECORDING

Direct recording is the title given to lacquer records which are made for immediate playback. The discs have cores of high-grade aluminium and are coated with a black cellulose lacquer which is sufficiently soft to permit efficient cutting, and yet hard enough to give as many as 50 playings of reasonable quality provided a light-weight pick-up with suitable needle and adequate lateral freedom is used. One playing with the wrong type of needle or pick-up is sufficient to ruin the recording completely. These points are clearly shown in the following photomicrographs by Mr. Watts. Incidentally, the grooves show frequencies similar to the commercial disc of Fig. 74, the music again including cymbals, thus disproving the statement sometimes made that lacquer discs are too soft for the reproduction of frequencies above 8,000

The illustrations 59A, B and C should really be studied along with the photomicrographs of Chapter 26. Although lacquer discs are not normally used by the home listener, it will be understood that any pick-up and stylus which will play these soft records without undue wear must give a very long life to the much harder commercial pressings.

Recording studios are now to be found in all large towns where records may be made by amateurs or professionals at a reasonable cost. The direct recording is immediately available, and extra copies can be "dubbed"¹ if required.

The most attractive quality of these direct recordings is the almost complete absence of surface noise. Furthermore, as they are not processed there is also a complete absence of the type of distortion which may arise during the various stages of processing of commercial pressings. On the other hand, it is hardly possible to devote to such recordings the rehearsal time and attention to detail which ensure the degree of dynamic and technical perfection now expected in a commercial record.

It will be appreciated that a feather-weight pick-up tracking at $7\frac{1}{2}$ grammes, which scarcely leaves a mark when run on a lacquer blank, will play direct recordings with very small effect on the grooves. The above estimate of 50 playings could be substantially increased under such conditions.

¹Dubbing means re-recording from one record to another by use of pick-up.

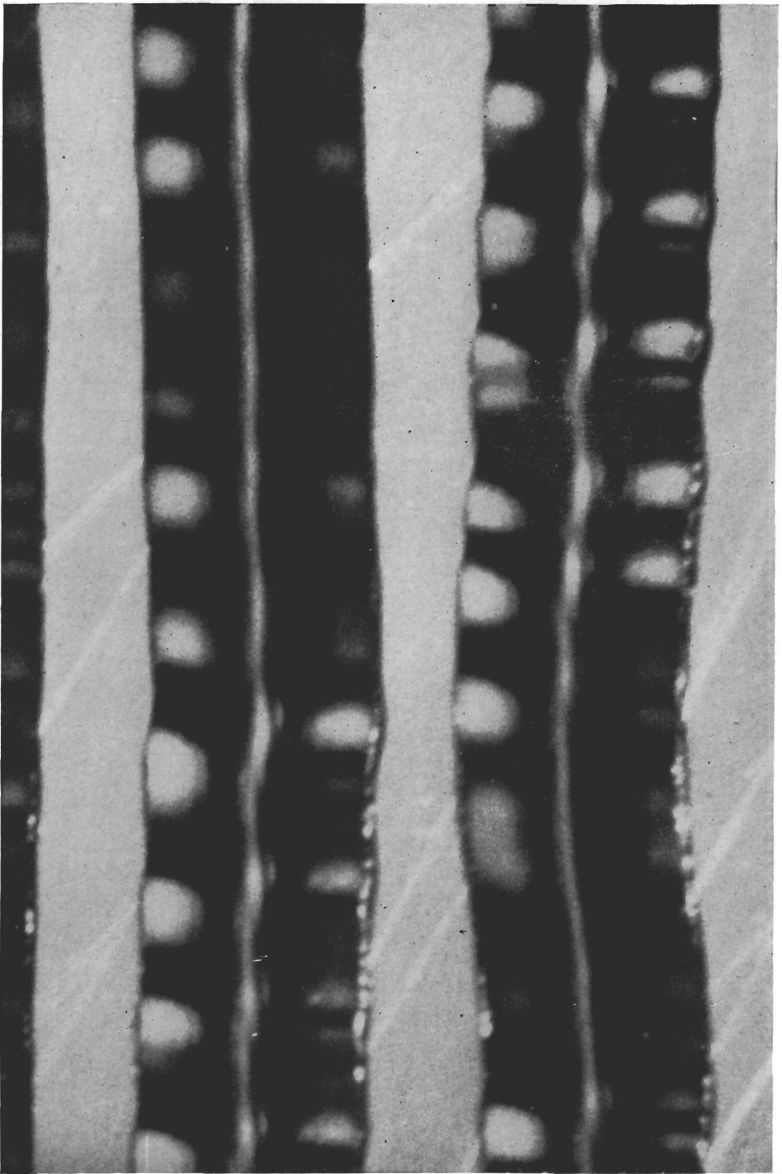

NEW LACQUER DISC - DIRECT RECORDING

FIG. 59A.

Photo. by C. E. WATTS. 200X.

Photomicrograph showing wave-formations of cymbals at about 14,000 c.p.s., taken at disc diameter of $8\frac{1}{2}$ inches. Recording at 78 r.p.m.

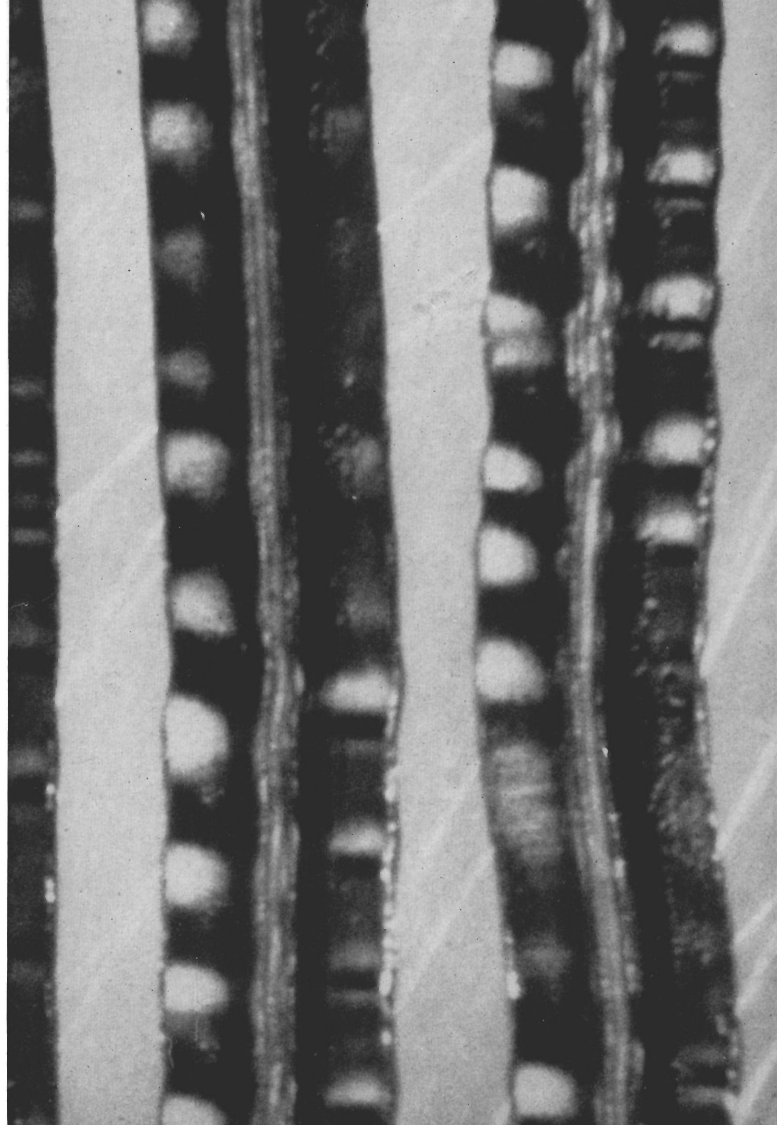

LACQUER DISC AFTER FIFTY PLAYINGS
DIRECT RECORDING

FIG. 59B.

Photo. by C. E. WATTS. 200X.

This remarkable photograph shows very little wear compared with 59A and proves the importance of low vertical inertia and good lateral freedom in avoiding wear. Weight on needle 25 grammes.

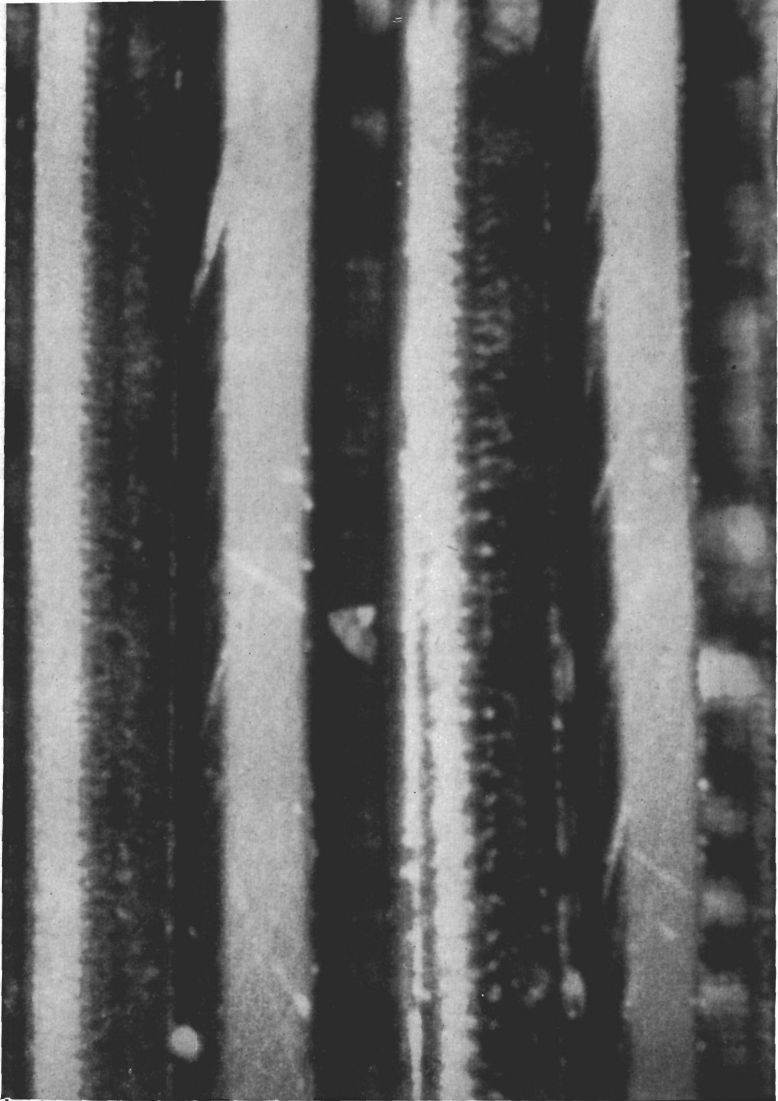

LACQUER DISC AFTER ONE PLAYING
WITH ORDINARY STEEL NEEDLE IN
PRE-WAR HEAVY PICKUP

FIG. 59C.

Photo. by C. E. WATTS. 200X.

This picture shows the "pushing up" of the wall of the groove which is caused by heavy pick-up or soundbox when used on lacquer, resulting in early loss of "top".

CHAPTER 24

B.B.C. RECORDING

In view of the important part played by recording in modern broadcasting, it is interesting and informative to examine some of the methods used by the B.B.C., and I am indebted to the Engineering Division for permission to do so and for providing me with the relevant information.

The complaint is often made that too many recorded programmes are used, and it must be agreed that in unscrupulous hands the system could easily lead to abuse. But the B.B.C. are not unscrupulous, and it is always announced that a programme was recorded when such was the case. I believe that recordings are made and used only for a very good reason, and not because the recording engineers are short of a job, and I can see no objection to the practice so long as old meat is not served up as fresh.

The most remarkable thing about the best B.B.C. recordings is the excellent quality. I used to boast that I could spot a recorded programme at any time on wide-range reproducing equipment. I should hesitate to make such a claim to-day. Although discs with a normal playing time of 15 minutes are used, the best recordings are limited to 10 minutes a side in order to avoid undue drop in surface speed. By careful listening it is just possible to detect the improved H.F. response when the change is made to a new disc at the end of each 10 minutes' period.

No doubt many readers will be surprised to learn that at present (early 1949) 80% of the recording done by the B.B.C. is on discs. Good features of direct disc recording are:—¹

1. It is possible to check the recording as it is made by fitting a reproducing head and arm to the recording machine.
 2. The lacquer disc is ready for immediate playback.
 3. It is convenient for the kind of editing which requires extracts from several discs.
 4. It is the most satisfactory of all known systems for archive work, since it can be plated and a metallic matrix made as in the record industry.
 5. Copies can be produced as required and sent to any part of the world.
 6. A large number of discs can be stored in a small space.
 7. It is possible to achieve the desired figure for signal/noise ratio.
- The chief disadvantage is the reduction of track speed towards the centre of the record. If the system is designed to give the desired

¹ M. J. L. Pulling, B.B.C. Quarterly, July 1948.

frequency response at the outside of the disc, the upper frequency limit will be an octave lower half way in to the centre. Radius compensation can be used within limits to emphasise the upper frequencies as the recording head travels across the disc.

SURFACE SPEED

The speed in relation to diameter is seen in the following diagram.

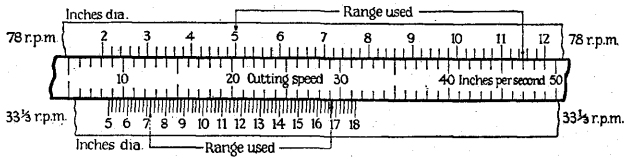

From *Journal I.E.E.* H. Davies, July 1947

FIG. 60 Cutting speed at various recording diameters.

Turntable speeds of 78 and $33\frac{1}{3}$ r.p.m. are used, the latter giving a playing time of 15 minutes per side without any reduction of groove size, with a 17 inch disc. It will be observed that between $11\frac{1}{2}$ and 17 inches the surface speed at $33\frac{1}{3}$ r.p.m. is equal to $\frac{5}{7}$ inches diameter at 78 r.p.m.

In other words, the extra size makes up to a certain extent for the slower turntable speed. Small wonder that the $33\frac{1}{3}$ system is mainly employed, as a complete half-hour programme can be accommodated on two sides if necessary.

It is the writer's opinion that a ready market would have been found for commercial records about $\frac{15}{17}$ inches diameter to play 15 minutes at $33\frac{1}{3}$ r.p.m. The proposition strikes him as superior to elaborate and troublesome automatic record changers, and simpler than the change to microgroove systems which has commenced in America.

The large discs would require a 12 inch tone arm instead of the usual $\frac{9}{10}$ inch, with, incidentally, reduced tracking error, and, of course, a two-speed turntable. The normal groove could be used, and the same pick-up would serve for both types of record. Microgroove discs require a special pick-up with a fine stylus of $\cdot 001$ " radius, and there is always the difficulty of maintaining quality at the very slow surface speed at a small diameter. Ultra-lightweight pick-ups already need handling with extreme care, and there is much to be said for the more robust system of the larger disc. It is, of course, impossible to use the normal pick-up and needle on microgrooves, and recourse to the use of the fine microgroove needle on standard records would result in distortion, and damage to the grooves.

A brief description of the equipment used by the B.B.C. now follows.¹ A big increase in the demand for sound recording was experienced, particularly in the European and Overseas services,

¹ From "I.E.E. Journal"—(H. Davies).

C. RECORDING

and this has been met mainly by an increase in the facilities for lateral recording on cellulose-coated discs. As there was no equipment available which could meet the B.B.C. requirements in fidelity and trouble-free operation, the B.B.C. Research Department undertook the development of suitable equipment.



FIG. 61—B.B.C. Disc recording channel, comprising two recording machines, control desk and two suction units for pneumatic removal of swarf.

B.B.C. Quarterly, July 1948

Recording speeds of 78 or $33\frac{1}{3}$ r.p.m. can be used, and each machine incorporates a scrolling motor for a very large opening out of the groove spacing. These motors can be simultaneously operated from a button on the control desk. To facilitate the change-over from the end of one record to the beginning of another there is an overlap portion during which the wide groove spacing is applied to both records. This can be seen at a glance when the records are being played for transmission.

TURNTABLE DRIVE

A schematic diagram of the drive unit is shown in the next figure

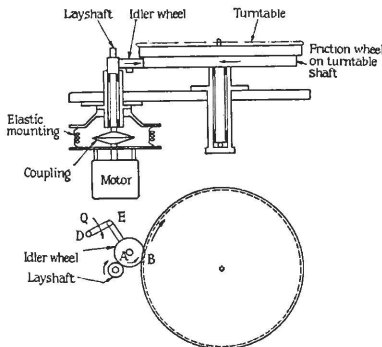

FIG. 61A.—B.B.C. Turntable drive

From I.E.E. Journal, July 1947

The $\frac{1}{8}$ h.p., 1,500 r.p.m. synchronous motor is suspended by an elastic mounting, and the drive is transmitted to turntable by a friction wheel. The motor is also provided with a pair of vibration absorbers, each consisting of a weight on the end of a steel rod and arranged to resonate at the rotational frequency of the motor, 25 c.p.s. (Patent Application 15479/45).

The upper end of the layshaft is stepped, so that by engaging a neoprene idler wheel between the larger or the smaller diameter and the friction wheel on turntable, speeds of 78 or $33\frac{1}{3}$ r.p.m. are obtained.

GROOVES

A normal groove size is cut, and the grooves per inch are 120 for $33\frac{1}{3}$ r.p.m. and 104 for 78 r.p.m. recording.

FREQUENCY RESPONSE

The degree of radius compensation used is shown in Fig. 58, Chapter 14, and the following diagram gives the overall response at the beginning and end of each type of record.

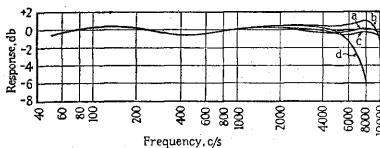

- A. Beginning of 78 r.p.m. recording.
- B. End of 4 min.: 78 r.p.m. or 10 min.: $33\frac{1}{3}$ r.p.m. recording.
- C. Beginning of $33\frac{1}{3}$ r.p.m. recording.
- D. End of 15 min.: $33\frac{1}{3}$ r.p.m. recording.

From I.E.E. Journal, July, 1947.

FIG. 62.—Overall frequency characteristics of B.B.C. records.

The size of disc is the usual 12" at 78 r.p.m. and $17\frac{1}{4}$ " diameter at $33\frac{1}{3}$ r.p.m. It is pointed out that the full 15 minute recordings are only used when long playing time is important and a somewhat inferior fidelity is acceptable.

SUMMARY

The number of discs cut by the B.B.C. is about 5,000 a week. Many of these are processed and Vinylite copies are sent to other Broadcasting concerns in many parts of the world. With such a vast output it is not surprising that some recordings fall below the average standard, especially when they are made in circumstances where high technical quality is impracticable, such as on outside locations.

RECORD LIBRARY

In addition to the above, the B.B.C. Library of commercial records runs into a total of 250,000 discs. Such a collection must contain many odd recording characteristics and numerous groove shapes and sizes, against which it is impossible to adjust the reproducing characteristic continuously. It is not surprising, therefore, that a programme such as "Housewives' Choice" results in varying standards of quality.

COMMERCIAL REPRODUCTION

In playing commercial records, the B.B.C. start to cut response gradually above 4,000 cycles, and more steeply above 6,000 cycles. Arrangements are made to remove this attenuation when B.B.C. recordings are played. No scratch filter circuit is employed.

PICK-UPS AND NEEDLES

With such large-scale activities, reliability and convenience in use are essential qualities in all accessories. A number of pre-war B.T.H. Needle Armature pick-ups are still in use, but they are being replaced by a modified version of the E.M.I. Type 12 pick-up (similar to Type 14). Sapphire needles with the usual .0025" radius are used throughout, and each needle is inspected daily by shadowgraph.

CHAPTER 25

SAPPHIRE, TUNGSTEN-CARBIDE AND DIAMOND

The majority of the gramophone needles used in modern pick-ups are made in one of these substances. A brief examination of their nature and qualities will, therefore, be of some interest to many users.

SAPPHIRE

Synthetic sapphire is now almost universally used for commercial purposes. It is generally considered to be superior to natural gem stones as it suffers from fewer defects and impurities.

Ruby and sapphire are gem stones of the corundum family and have the same characteristics, the difference in colour being due to impurities in the stones. Almost any colour of the rainbow can be produced in synthetic sapphire by "alloying" with suitable oxides, but without improving its physical and mechanical qualities.

Prior to World War II, all the sapphire used in this country was imported, chiefly from Switzerland. When supplies were cut off, a manufacturing plant was installed by Salford Electrical Instruments Ltd., who are still the only producers of synthetic sapphire in the British Isles on a commercial scale.

The material is produced under a system perfected by Verneuil early in the twentieth century. It is actually an artificially grown crystal; the process is extremely interesting to watch. Aluminium, sulphuric acid and ammonia are fused in a furnace at $1,000^{\circ}$ centigrade, producing finely powdered alumina which is sieved through an oxygen-hydrogen flame at about $2,000^{\circ}$ centigrade, melting and impinging on a refractory pedestal to form a "boule" about the size of a pigeon egg, or a rod about 1' long and $\frac{1}{8}$ " diameter. The rod is the most convenient shape for the production of gramophone needles.

Fabrication is accomplished entirely with diamond. Grinding, lapping and polishing are done with diamond dust, the final process requiring dust particles of not more than one micron (one-thousandth of a millimetre) in size. The resulting smooth surface puts polished sapphire in a class by itself where the lowest possible coefficient of friction is required. The material is used for bearings in instruments and watches, for plug and ring gauges of extreme accuracy, and for thread guides in the rayon industry where minimum friction is essential.

There is a complete absence of porosity of surface, as the following reproductions show:

PPHIRE, TUNGSTEN-CARBIDE AND DIAMOND

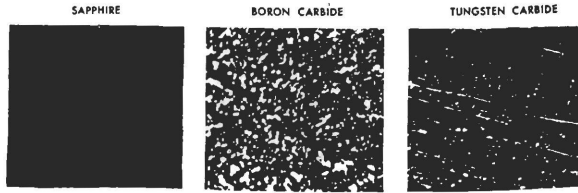

Courtesy Armour Research Foundation, U.S.A.

FIG. 62/1.—Photomicrographs prepared by Armour Research Foundation under dark-field illumination to compare the surface porosity of polished sapphire, boron-carbide and tungsten-carbide.

Sapphire tipped styli are now generally preferred for the cutting of discs, as the polished grooves they produce result in low surface noise. The same argument does not necessarily apply to reproducing styli.

The polishing of hard tips for stylus use has been reduced to, or raised to, a fine art. Reputable makes may now be purchased with full confidence that the radius, contour and finish are satisfactory. Final inspection is usually made by shadowgraph. The following photograph shows a microgroove needle in relation to a perfect outline:

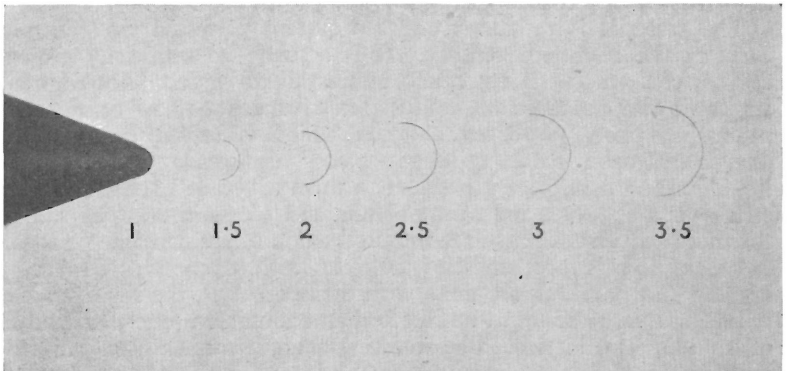

Courtesy Salford Electrical Instruments Ltd.

FIG. 62/2.—Shadowgraph inspection of size and shape of microgroove stylus. Figures indicate tip radius in mils.

Sapphire needles are on the market at 6s. 9d. upwards, according to type. Considering the time, accuracy and individual attention involved in production, and the long life to be expected under healthy conditions of use, prices must now be considered to be very reasonable

TUNGSTEN-CARBIDE

The question of relative merits of sapphire and tungsten-carbide for use as gramophone needles seems to be taking longer to settle than the record "war" in America, which apparently is all over, including the shouting (not shooting). The situation has been complicated by the fact that there are many different grades of tungsten-carbide, and a test with an unsuitable grade has the effect of undermining the position of the material in general. Another difficulty is that the hardest grade is not necessarily the toughest from the stylus point of view. It is in fact now admitted that sapphire is about 18% harder than a grade of tungsten-carbide found to be very suitable for stylus use.

Unlike sapphire, which is of crystal formation, tungsten-carbide consists of very fine powder, including a small proportion of cobalt and sometimes titanium carbide, and is formed by a sintering process. This results in a different type of wear, which is preferred by some experimenters, as the powdering off which eventually occurs does not leave the same pronounced flat that appears on a worn sapphire. Some people assert that this powder will increase the wear on records, but the quantity will be very small when spread over a number of records, and it should be removed with common dust in the normal process of cleaning.

The mesh size of tungsten-carbide powder is about 5 microns, say .0002". This represents a wavelength of 100 kc. at a surface speed of 20"/sec.; any wear or friction caused by the powder will at least be inaudible.

The substance is not so liable to fracture by rough treatment as sapphire. This was confirmed by a series of rather brutal tests. A sheet of very fine sandpaper was glued to a disc, and various points and shafts were allowed to run on the surface at 5"-6" diameter at 78 r.p.m., with a pressure of 1½ oz., for periods of 15 seconds and upwards. Fine steel needles were included among the victims for purposes of comparison. The following photomicrographs give a fairly true picture of the results.

The photographs of the shafts show the surface porosity of the material prior to the final polishing which is applied to the tips, and prove that these photomicrographs can, if required, be arranged to show the surface created by the final polishing process.

EFFECT OF RUNNING SHANKS 30 SECONDS ON ABRASIVE DISC.
SHANK DIAMETERS .030" APPROXIMATELY

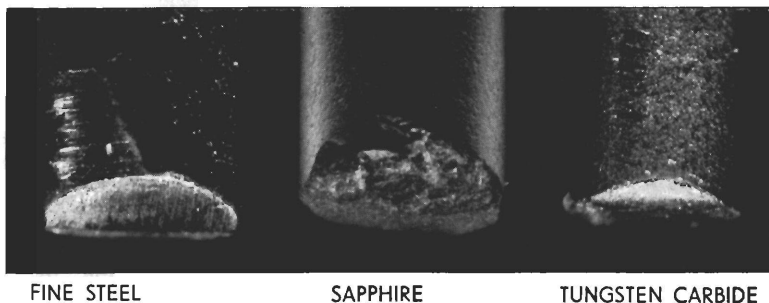

[FIG. 62/3.—Abrasive tests on needle shafts.

EFFECT OF RUNNING POINTS ON ABRASIVE DISC



Photo by C. E. WATTS.

FIG. 62/4.—Abrasive tests on needle points.

The abrasion of the steel point was limited to 15 seconds, as the end was being quickly ground away. The sapphire was badly fractured every time. This again confirms that sapphire is quite unsuitable for use in heavy pick-ups; nor should it be used in automatics if they are liable to jolts or jars. The suitability of sapphire for use in light pick-ups is in no way questioned, and should not be prejudiced by these tests. The toughness of tungsten-carbide of the correct grade is clearly confirmed. The material would appear to be ideal for use under conditions which have been found to be too rough for sapphire.

SURFACE POLISH AND WEAR

Attention has already been drawn to the magnificent finish which is developed on a polished sapphire. It appears that the method used for polishing sapphire is not satisfactory with tungsten-carbide, as it leaves some porosity of surface due to dragging out of fine particles of powder. Special methods of polishing tungsten-carbide are being devised. As regards wearing qualities on shellac discs, the grades so far tested by the writer have not shown any longer life than sapphire, but no doubt a suitably homogeneous grade will be forthcoming which will enable the undoubted toughness of this medium to be used to full advantage, especially in the fine points required for microgroove vinylite records.

WEIGHT

Another difference between the two substances is that a tungsten-carbide needle weighs about four times as much as an equivalent sapphire. In some modern pick-ups, such increase in weight would lower the frequency of resonance and may detract from the performance. Where a steel or duralumin shank is used, the difference in the weight of the tip would be of little or no consequence.

DIAMOND

Whereas the two materials already considered in this chapter are synthetic, diamond points are produced from the natural stone. The only possible objection to diamond as the ideal stylus for modern pick-ups is on the score of cost. The high prices are due to the time taken in shaping and polishing rather than to the original cost of the stone. Grinding diamond is a very slow process, as there is nothing harder than diamond dust to use as an abrasive. It is actually equivalent to shaping a piece of glass with glass-paper, except that in the process of grinding, a large area is brought to bear on a very small area. This accounts for the gradual wear of a hard stylus by the comparatively soft surface of a record. In the course of playing one 12" disc, the needle covers a distance of approximately 8,000". If we assume that the surface of the needle in contact with the record is .001" wide, the ratio becomes 8,000,000 to 1. In grinding, the ratio would not be so big, but would exceed 1,000 to 1, with a 6" wheel.

The following photograph proves that it is possible to obtain and retain a high degree of polish on a diamond point :

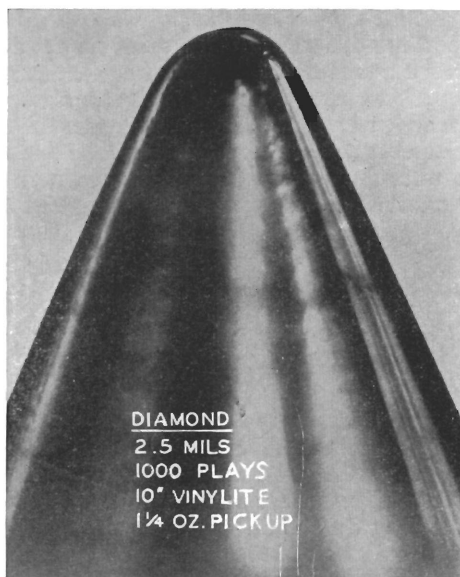

*Courtesy
The Tetrad
Corporation
Yonkers N. Y. 2,*

FIG. 62/5.—Photograph of Diamond after 1,000 playings at 78 r.p.m.

Taking a long view over a number of years, diamond is probably more economical than its cheaper rivals, as the absence of worn flats is very beneficial to the life of records.

I have not yet heard of a diamond point being fractured in use, and only small worn flats were reported by Decca after nine months' almost continuous use at eight hours a day on metal matrices. By comparison, sapphire used for the same purpose lasted barely a week.

The price of diamond-pointed needles in England is around £6, plus purchase tax of about £3. Rather lower prices seem to prevail in America.

It is important to remember that in all hard styli—whether sapphire, tungsten or diamond—it is essential to use a well polished point of correct size and shape, to avoid damage to records. Cheap needles of doubtful origin should be viewed with suspicion.

CHAPTER 26

NEEDLES AND GROOVES

It is now generally agreed that the reproducing stylus should have a spherical tip with a radius larger than the radius of the bottom of the groove, so that the tip rides on the sides of the groove, as shown in Fig. 63 at A and B, for normal grooves and microgrooves respectively.

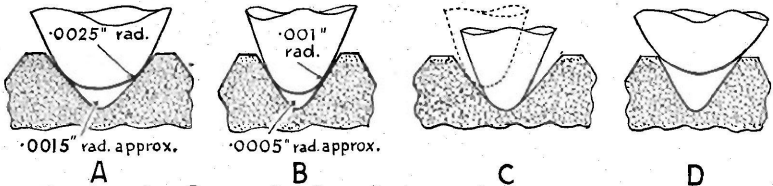

FIG. 63.—A. Correct fit of needle in standard groove.
B. Correct fit of needle in microgroove.
C. Needle too fine for groove.
D. Needle too big for groove.

Under conditions A and B maximum frequency response is attained with minimum surface noise and record wear. In the case of C, the needle point will tend to skate about in the groove as shown by dotted line, causing damage to the groove and distortion in reproduction. Fig. 63D shows a needle too big for the groove. This cannot follow the lateral cuts correctly, and will have a tendency to skate across the top of the record.

The present radius at the bottom of the groove is $\cdot 0015''$ in both Decca and E.M.I. recordings. In 1936 the groove radius was $\cdot 002''$ in Decca and $\cdot 0025''$ in H.M.V. records. A sapphire needle with tip radius between $\cdot 0025''$ and $\cdot 003''$ is satisfactory in these pre-war records, but a needle with very sharp point is not suitable. Pre-war records were actually made for use with the soft steel needles which are quickly ground to fit the groove. A fine hard steel needle would probably do considerable harm before wearing sufficiently to suit the wide groove.

A considerable increase in surface noise will occur if the needle is so small that it rides on the bottom of the groove, in addition to increase of distortion.

In an examination of the problems of needle and record wear and frequency response, the use of actual photographs is a most valuable asset. I consider myself fortunate in having had the co-operation of Cecil Watts, whose photomicrographs enjoy a nation-wide reputation and are probably unsurpassed in any part of the world. All the photographs reproduced in the following pages have been specially taken for this book, and all are magnified 200 diameters. None of the photographs has been touched up.

FREQUENCY AND WAVELENGTH

The first thing to consider in relation to response is the actual wavelength at different diameters (or surface speed). This can be found for any frequency up to 10 Kc/s. by the following diagram, after reference to the cutting speeds of Fig. 60 in Chapter 24.

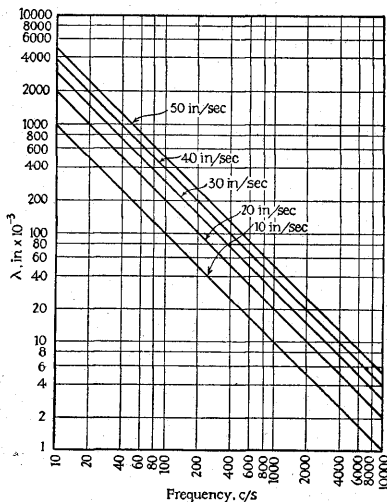
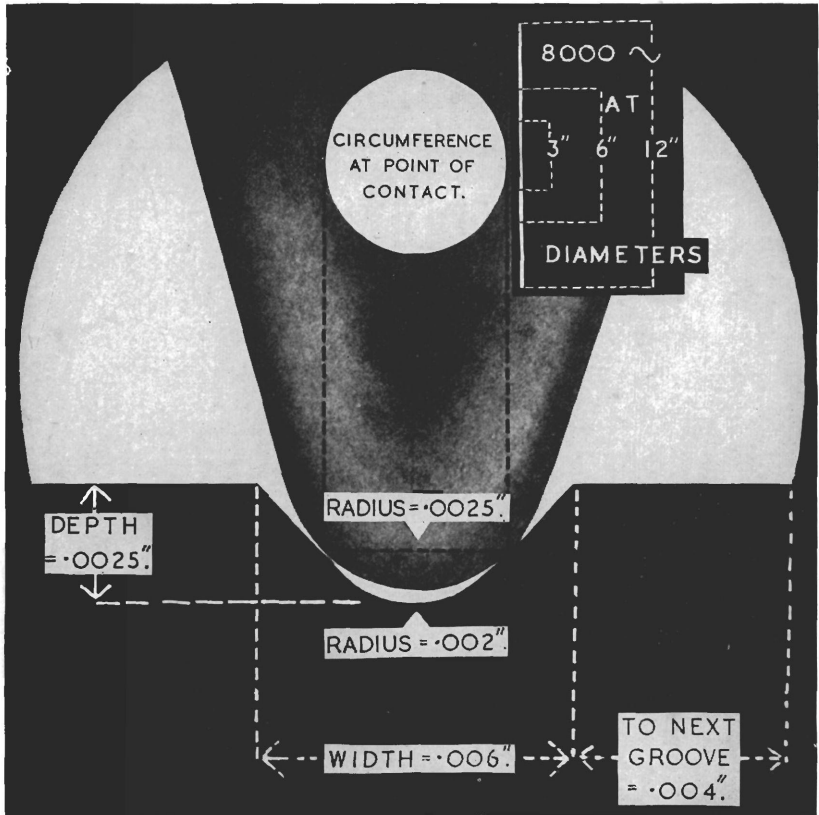

FIG. 64.—Variation of wave length with frequency at various cutting speeds.

From Journal I.E.E.
H. Davies, July 1947.

Assuming it is desired to know the wavelength of a note of 4,000 cycles at 10" diameter at 78 r.p.m., reference to Fig. 60 gives a cutting speed of 41 inches per second. Reference to Fig. 64 shows a wavelength of 0.010" for 4,000 cycles at 40 inches per second. At 5" diameter the speed is 20½ inches per second, and the wavelength is also halved at 0.005". It is clear that any needle with a flat surface of more than 0.005" could not reproduce a 4,000 cycle wave formation at 5 inches diameter on a normal record. The flat would merely bridge across the sound waves. The following two diagrams will make this even more clear, and will also indicate what happens when a steel needle is worn "to fit the groove".

The sphere of the needle point in Fig. 65 can easily respond to the 8 Kc/s wave even at 3" diameter, as the section in contact with the groove is smaller than the sound wavelength. Compare this with the next illustration, Fig. 66.



By C. E. Watts, Sunbury on Thames.

FIG. 65.—Diagram showing groove and needle size compared with 8 kc/s wavelength at different diameters at 78 r.p.m.

SHAPE OF POINT

Although a spherical shape gives excellent results, improvement in response and reduction of tracing distortion are possible with an oval tip. The major axis is placed at right angles to the groove, so that a radius of about $\cdot 001''$ comes in contact with the groove walls. The reduction of contact area increases the pressure and accelerates the rate of wear. It is therefore advisable to reduce the weight on record as much as possible. Another effect of the extra pressure is to lower the frequency of the natural resonance. The design of a pick-up may require modification for maximum results with an oval tip.

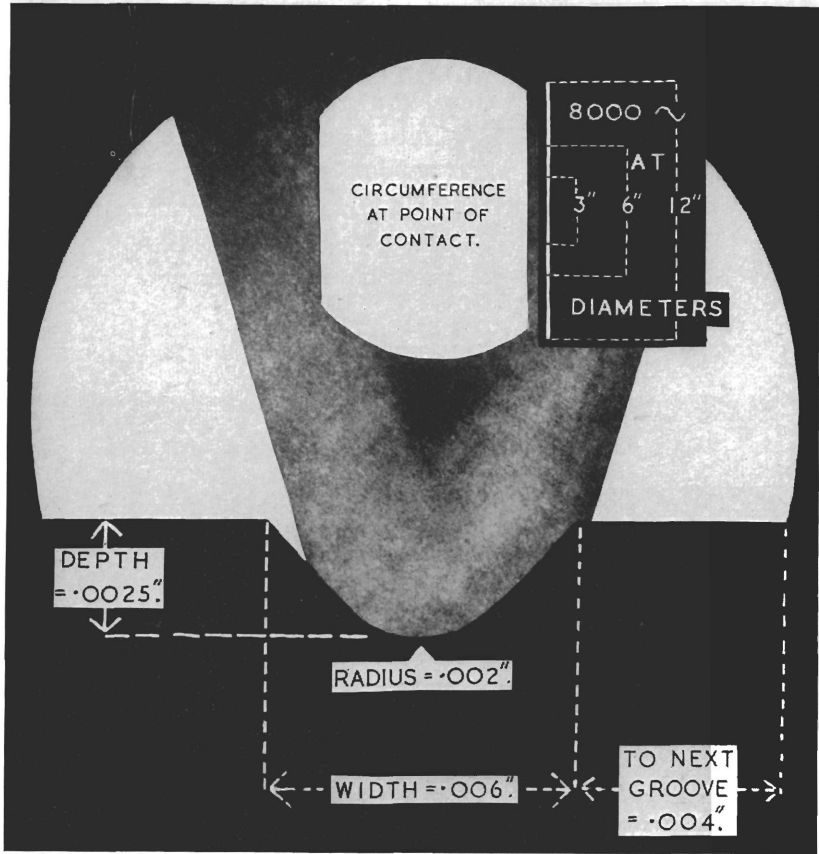

By C. E. Watts, Sunbury on Thames.

FIG. 66.—Diagram showing steel needle worn to fit the groove, with resultant flats.

The flat on one side of the needle is greater than the wavelength of 8,000 cycles even at 8" diameter, and reproduction of this or any higher frequency is therefore impossible under Fig. 66 conditions.

FIBRE NEEDLES

Many Gramophone Societies and private gramophiles still continue to use fibre or similar needles to reduce record wear and surface noise. I should like to make it clear that I have no quarrel with such people and I raise no objection to the practice. The fact that these objects are achieved by loss of top concerns only the listeners themselves. It is quite a simple business to prove the loss of top by the following photographs, which illustrate the devastating effect of one playing on the needle point.

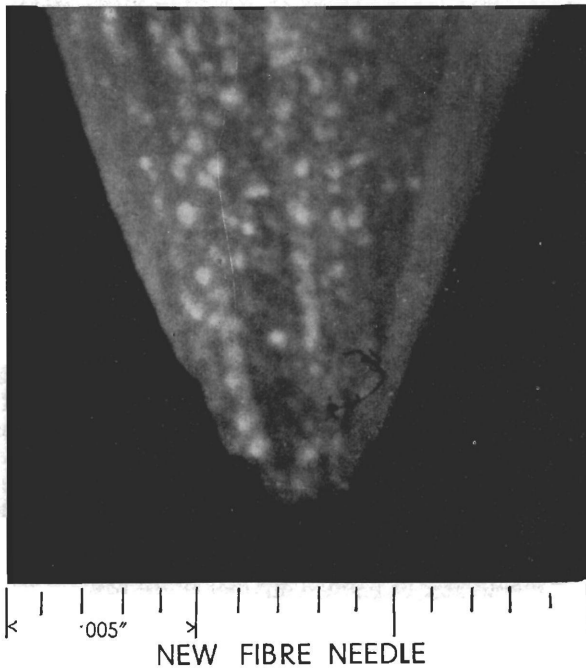

FIG. 67A.

Photo by C. E. WATTS. 200X.

Apart from early loss of shape during playing, needles of the fibre class have low Young's Modulus and do not constitute a suitable medium for transmitting vibrations at high frequencies. About half way through a record the fibre begins to look like a blunt instrument, and to expect this to trace the modulated groove is on a par with trying to fill in a crossword puzzle with a poker. See Fig. 67B.

FIG.
67B.



Photo. by
C. E.
WATTS.
200X.

NEW FIBRE NEEDLE AFTER ONE PLAYING
ON NEW 12" PRESSING
STEEL NEEDLES

There are two main classes of steel needles—the pre-war large needle in soft steel, and the finer hypersensitive hard steel needle which is sometimes chromium plated to increase its hardness. The soft steel needle is quickly ground to fit the groove and is intended to be discarded after one playing. Fig. 66 furnishes good evidence that such needles would not do justice to the wide frequency range of modern recordings.

The following tests relate to fine needles as used in light-weight pick-ups. It should here be pointed out that all the needles and records used in these tests were bought over the counter in the usual way, and they constitute a fair sample of what is on sale to the general public. In no case was the maker of the article aware that the tests were being made.

All the photographs are magnified 200 diameters; therefore one inch on the reproduction represents $\cdot 005$ " in actual size. A scale is provided with each illustration, the smallest division equalling one-thousandth of an inch.

Inspection of Figures 68 and 69 reveals a good deal of wear on the fine steel needle after one playing. Although this type of needle is usually rated to play ten or more times, it is clear that caution is necessary to avoid undue wear on records, and loss of high frequency response is already in sight

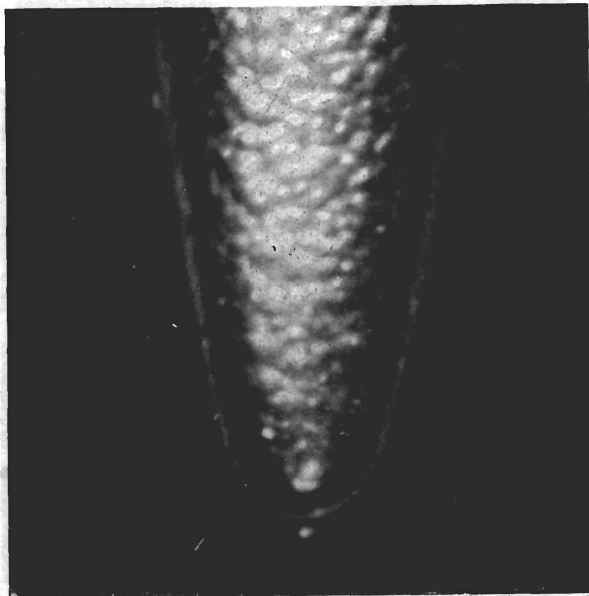

FIG.
68.

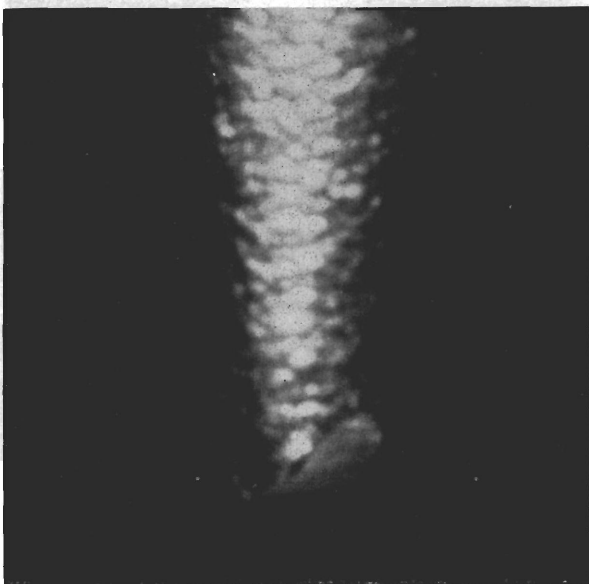
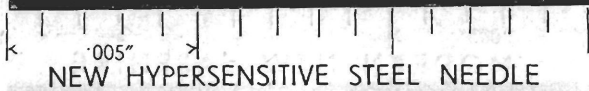
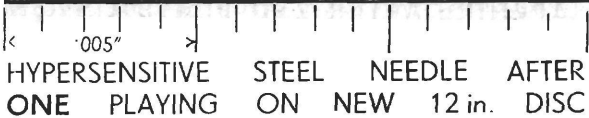

FIG.
69.



*Photo. by
C. E.
WATTS.
200X.*

The wearing qualities of a good sapphire when used with 25 gr. pick-ups are clearly shown in Figures 70 and 71.

Although later tests with lighter pick-ups tracking at 14 gr. or less reveal much less wear on points and records, the 25 gr. reports are retained as statements of fact, as many of these pick-ups will still be used on automatics and where the ultra-light design would not stand up to the conditions of use.

It should be noted that the present chapter is concerned with 78 r.p.m., where one playing means about 4 minutes, compared with 22 minutes for one microgroove playing. Reports on microgroove tests appear in Chapter 32.

To revert to Figures 70 and 71, some wear is evident on the sapphire after 250 playings (about 16 hours) with a weight of 25 gr., but as the rate of wear decreases as more surface is in contact with the record, it is reasonable to assume that the needle would give about 500 playings without undue distortion, under similar conditions of use.

The brittle nature of sapphire has already been demonstrated in the previous chapter. In this connection it is interesting to speculate on what has happened to the metal which is missing from the steel needle of Fig. 69. The next photograph, Fig. 72, furnishes a part of the answer.

Some at least of the missing steel is embedded in the record grooves, and discs which have been frequently played with steel needles are likely to damage a brittle stylus point in subsequent use, as shown in Fig. 73.

It is advisable to inspect a sapphire regularly, especially if used on part-worn records, so that a damaged point may be found before further damage is done to records. Methods of inspection are described in the next chapter.

There is now a good deal of evidence to show that tungsten-carbide needles, being tougher, would be much more satisfactory than sapphire for use on steel-infested discs, but no doubt users who are accustomed to soft steel or fibre will continue to use these styli on old recordings.

Figures 72 and 73 should be studied in the light of the above remarks. The test was made with 25 gr. pick-up. No doubt a lighter weight would reduce the risk of damage.



MODERN SHELLAC DISC AFTER ONE PLAYING WITH STEEL NEEDLE

Photo by C. E. WATTS. 200X.

FIG. 72.—Steel flakes embedded in groove wall after one playing of new pressing.



SAPPHIRES AT 14 GRAMMES OR LESS

It would not be an exaggeration to say that the ultra-light pick-up virtually solves the problem of record and needle wear. Models are now available which will track at $7\frac{1}{2}$ gr., and can be run at 78 r.p.m. on a lacquer blank without marking the surface. This means that all wear from downward pressure is removed; also that lacquer discs (direct recordings) may be played back a large number of times without deterioration. The next two photographs, 73A and 73B, show a big reduction in the rate of wear, compared with previous tests. The pick-up involved is the Cosmocord G.P.20 tracking at $7\frac{1}{2}$ gr., playing the "Danse Macabre" record as used in the series of tests outlined with 25 gr. pick-ups.

It should be pointed out that the G.P.20 is normally supplied to track at 12-14 gr. in order to stand up to adverse conditions from rough motors, warped or damaged records, swingers, etc. The extra weight increases slightly the rate of wear, but the $7\frac{1}{2}$ gr. results are reproduced

here because the pick-up will track at this weight under good conditions, and other pick-ups are available which possess the light fantastic touch so much to be desired. Models which come to mind are the good moving coil types, Brierley units, and the new Connoisseur ultra-light magnetic.

The first of the two photomicrographs, Fig. 73A, shows the amount of wear after 800 playings, about 50 hours, using only four records, i.e. second side of "Danse Macabre" played 200 times before being discarded.

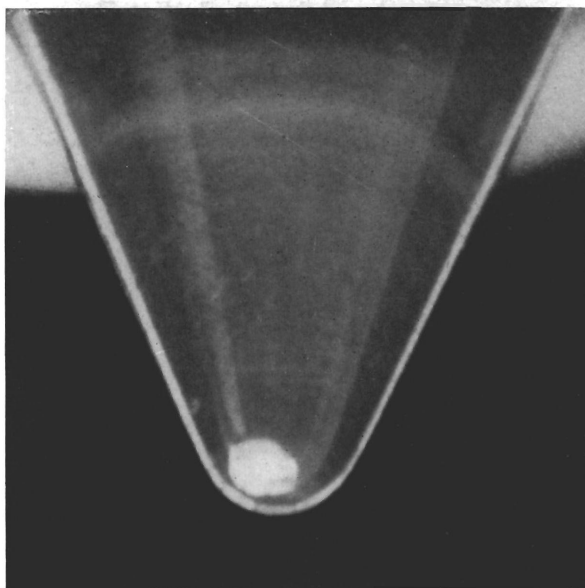

Courtesy Cosmocord Ltd.

FIG. 73A.—Sapphire after 800 playings (50 hours) in crystal pick-up at $7\frac{1}{2}$ grammes.

The next photograph, Fig. 73B, was taken after 2,000 playings, approximately 130 hours, and shows that the rate of wear during the second period of 1,200 playings was less than during the first period of 800.

Photo by C. E. WATTS.

Magnification 200.

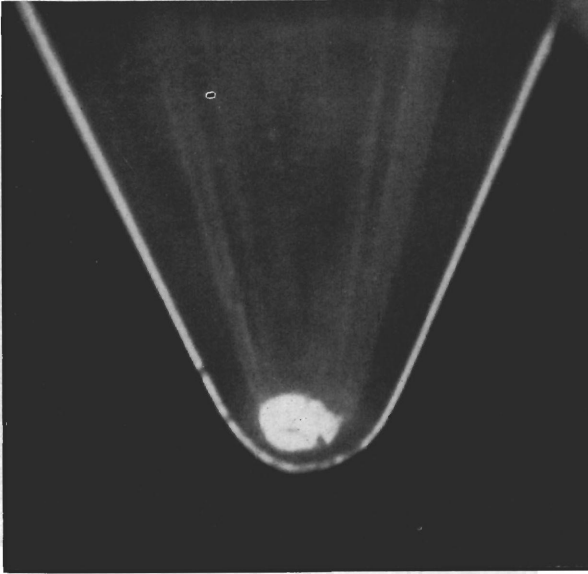

Courtesy Cosmocord Ltd.

FIG. 73B.—Sapphire after 2,000 playings (130 hours) in crystal pick-up at $7\frac{1}{2}$ grammes.

While dealing with the pressure of $7\frac{1}{2}$ gr., let us take a look at the records. We find that what is sauce for the goose is sauce for the gander. Figure 73C gives a picture of one of the above records after 200 playings.

The left-hand groove shows slight wear at the points of rapid acceleration. The high frequencies in the straight groove are scarcely marked. The section of record reproduced is taken from a very large photograph and was selected to show maximum wear.

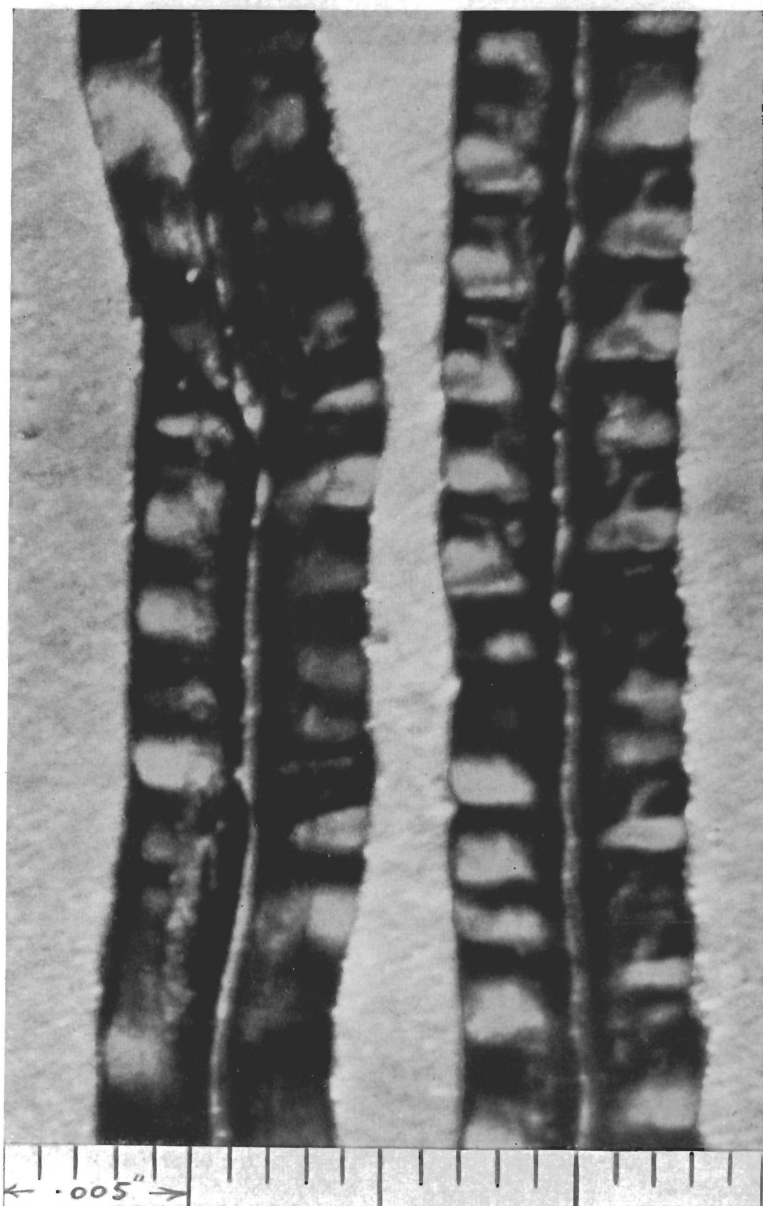

Photo by C. E. Watts.

FIG. 73C.—Section of "Danse Macabre" record after 200 playings with crystal pick-up at $7\frac{1}{2}$ grammes.

RECORD WEAR

The next three photographs, Figs. 74 to 76, illustrate the record wear associated with pick-ups of the 25 gr. variety, compared with the lighter weight already referred to in Fig. 73C. The importance of lateral compliance is demonstrated; but it must be admitted that Fig. 73C at 200 playings puts a fresh complexion on the whole problem.

The fourth photograph, Fig. 77, shows the devastating effect of a steel needle used in an ordinary acoustic sound box. A permanent stylus used under the same conditions would do even more damage to the record.

Attention has already been drawn to the fact that ordinary retail sources of supply were used for the materials forming the basis of these tests. For the record tests, twelve copies of a new 12" recording issued in January, 1949, were purchased, and the next three photographs are taken at the same section of the disc, at a diameter of $8\frac{1}{2}$ ". The frequencies include Tympani and Cymbals, and the shortest wavelength shown is about half an inch long, which represents an actual wavelength of $\cdot 0025$ ". This is pictorial evidence of recording at about 14,000 c.p.s. To check this, assume a wavelength of $\cdot 010$ " (four times $\cdot 0025$ "). Refer to Fig. 64 and $\cdot 010$ " at 35 inches per second gives 3,500 cycles, which multiplied by 4 is 14,000. It is necessary to work this out at a longer wavelength than $\cdot 0025$ " because Fig. 64 only goes up to 10 Kc/s.

NEEDLE TESTS—SUMMARY.

It hardly seems necessary to add many words of explanation to this range of photographs. To a large extent they speak for themselves, and they furnish strong evidence that sapphire and similar needles will give long service and inflict small damage on discs if used under proper conditions. At the same time they will give maximum response range, especially towards the centre of the record where response falls off and where softer needles wear flat and accentuate the loss, with increased distortion.

It is true that a stiff movement needs weight to hold the needle in the groove, and therefore a very stiff lightweight design is an impossibility. It is equally true that a pick-up which will track correctly with very light weight on stylus must possess lateral freedom. Even so, there are many degrees of stiffness in the light-weight class, and it is not possible to decide the question merely by comparison of needle pressures. An estimate of lateral freedom can be made by gently moving the needle point from side to side with the finger nail, care being taken not to cause excessive displacement which would upset the centring.



FIG. 74.—New modern pressing.

Photo. by C. E. WATTS. 200X.

The above picture only represents a minute portion of the disc = $1/33" \times 1/50"$. The only way to show a larger area would have been by reducing the magnification, which would have largely discounted the value of the work.

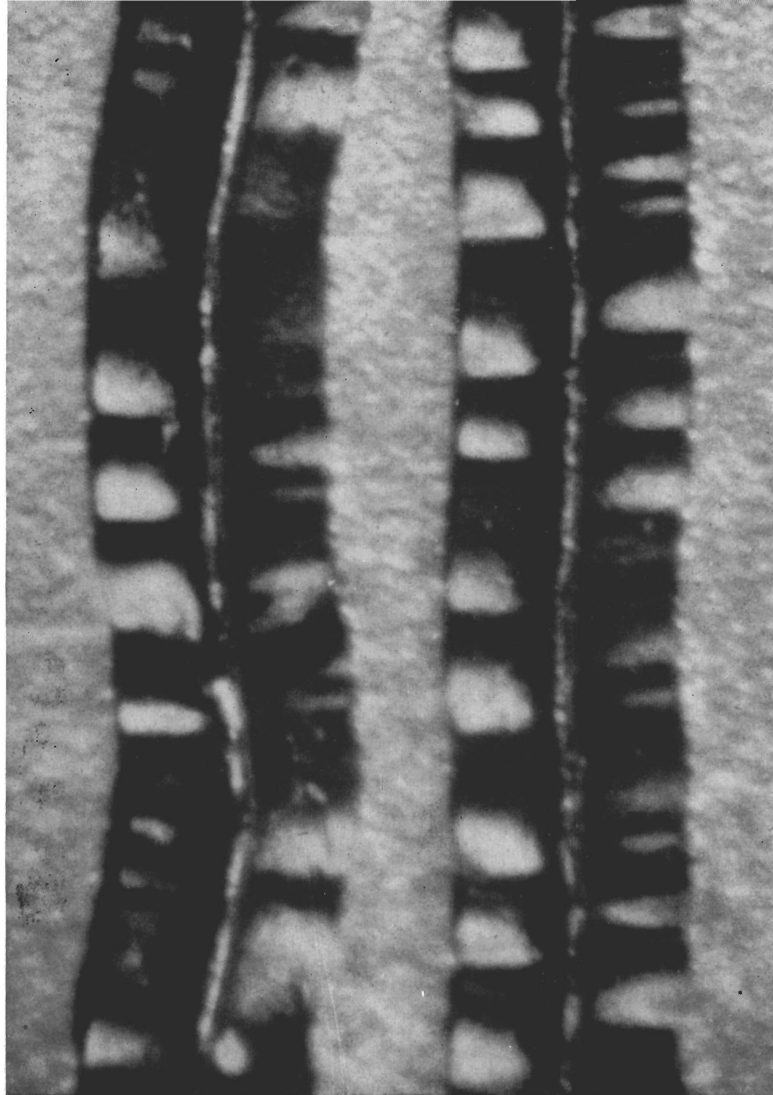

MODERN SHELLAC DISC AFTER TWENTY PLAYINGS
WITH SAPPHIRE IN APPROVED LIGHT-WEIGHT
PICKUP

FIG. 75.

Photo. by C. E. WATTS. 200X.

Comparison of this photograph with Fig. 74 shows only the slightest trace of wear; certainly not enough to cause any deterioration in the quality of reproduction even at the high frequencies involved. Weight on needle 25 grammes.



0.005"
MODERN SHELLAC DISC AFTER TWENTY PLAYINGS
WITH SAPPHIRE IN ORDINARY LIGHT-WEIGHT
PICKUP

FIG. 76.

Photo. by C. E. WATTS. 200X.

Here are to be seen unmistakable signs of groove damage, due to lateral stiffness in the stylus mounting. The pick-up weight was no greater than the type used in Fig. 75. Lateral freedom of stylus movement forms the basis of good pick-up design and long life of records.



MODERN SHELLAC DISC AFTER TEN PLAYINGS
ON ACOUSTIC GRAMOPHONE

FIG. 77.

Photo. by C. E. WATTS. 200X.

This picture tells its own story. Chunks of steel (in the record sense) are visible, and in some places the needle has ploughed its own groove in preference to following the original. The moral is-- don't lend your favourite records to a picnic party.

CHAPTER 27

NEEDLE INSPECTION

The use of Tungsten, Sapphire, Diamond or other hard and costly points justifies the installation of some means of inspection to detect wear or damage. This will serve to protect records from undue wear and will also enable the user to obtain the maximum useful life from any given needle. It is not really satisfactory to rely on the ear for warning of trouble, as it is not always possible to locate a source of distortion with accuracy, and quite a lot of damage may be done during a period of uncertainty. Furthermore, the cost of the equipment may eventually be saved by rotating a worn stylus so that the unworn faces are placed in contact with the groove walls, thus doubling the life of the needle.

Inspection by shadowgraph gives the clearest outline of contour, but the cost of a suitable machine is rather high for occasional private use. A magnifying glass is not really satisfactory as there is not sufficient depth of focus.

A microscope with magnification of 60 or more, is undoubtedly the best proposition, provided it is fitted with a lens having a small enough aperture to give the necessary depth of focus (or a suitable adapter). Quite a cheap instrument will answer the purpose. The writer picked one up for 50s. with which it is easy to detect a flat of .0005".

In a room with only one window facing north, known in the textile trade as a "buying" light and always used for inspection of cloth, the microscope can be operated without the aid of artificial light, and without much dazzle from a very bright and shiny needle. Under less favourable conditions, it is advisable to have a shaded lamp of about 60 watts focused on the object. If necessary, another lamp of similar type may be placed at the opposite side of the microscope to balance the rays of light and reduce dazzle. It is possible to inspect at least half the surface of a stylus point in one view; the needle should, of course, be turned over for the inspection of the other side.

A rotating needle-holder is an obvious adjunct to quick inspection, but failing such a luxury it is a good plan to fix the needle to the slide with a small piece of adhesive tape. Both sides may then be examined by simply turning the slide over instead of fiddling with the needle.

In the case of sapphire, dazzle due to refraction of light may be overcome by immersing the needle in a small bath of bromo-naphthalene or trichlor-ethylene, the latter being obtainable from the chemist.

CHAPTER 28

DISTORTION AND TRACKING ERROR

Several forms of distortion have already been examined in previous chapters. The following remain to be looked at as briefly as possible. **WOW.** This is the term used to describe change of speed which causes the pitch of the reproduced sound to vary. The ear is very sensitive to changes of this type and minute variations are noticeable. Wow may be caused by non-uniform speed of turntable during recording or reproduction, centre hole out of place, groove distortion during processing, or variation in disc height from non-flat discs. The fault is not very prevalent in modern equipment of good make. A long tone-arm reduces the effect of wow from an undulating disc.

PINCH EFFECT

As the groove in a record is cut by a chisel, the width in the plane of the cutter movement remains constant, but when modulation occurs, the width across the groove varies. This is shown in the following diagram.

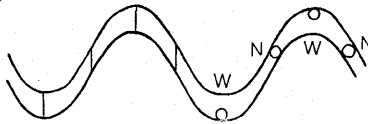

FIG. 78.—Diagram illustrating pinch effect. Vertical lines represent cutter. Circles represent needle.

The widest points are at the peaks of the wave formation marked W and the narrowest points are at N in Fig. 78.

The result is that the needle is “pinched” at positions N and tends to move up and down in the groove. As the N position occurs twice in one wave form there will be generation of second harmonic distortion if the vertical movement produces electrical output, and also wear on the walls of the groove. This only occurs to any serious extent where the stylus has a high mechanical impedance to vertical movement, as in cheap and heavy pick-ups. Diagrams illustrating the fault are usually exaggerated and the modern lightweight pick-up with low vertical inertia does not seem to suffer unduly from the trouble over the major part of the recording. The pinch effect is intensified towards the centre of the disc, where the wavelength is shorter and the angle more acute, at frequencies where the needle moves as a whole.

It ought to be noted, however, that the pinch effect is reduced at frequencies below 250 by recording at constant amplitude. Also, at high frequencies where the diameter of the needle is comparable to the wavelength, the needle ceases to move laterally as a whole and merely vibrates, so the trouble does not arise at frequencies above about 7,000 cycles at 10 in. diameter or 3,500 cycles at 5 in. diameter. Another comforting thought is that recording engineers have probably heard of the fault, which is an inherent phenomenon that has been accommodated by suitable design.

On the whole, therefore, we (the listeners) need not attach very great importance to the pinch effect with modern pickups, and the body might be prepared for interment along with the corpse of Herr Doppler which has recently been resuscitated in certain quarters.

The Doppler effect has even less to do with sound reproduction than has pinch effect.

TONE ARM RESONANCE

In some cases the tone arm resonance is located in the region of 50 to 100 c.p.s. to give a spurious increase of bass. A light tone arm combined with heavy rubber damping of the armature gives this effect, resulting in excessive record wear and "woolly" bass. The tone arm should be torsionally rigid and the mass of the head and arm should be high enough to keep the resonance down to 20 or 30 c.p.s. Reducing the lateral stiffness of the armature movement lowers the natural frequency at which tone arm resonance is set up. The falling L.F. characteristic of the recording should be equalised by amplifier design in preference to tone arm resonance.

The torsional resonance, due to twisting of the tone arm, usually occurs in the region of 600 cycles and is only a minor effect in an arm of good design fitted with a pickup with freely moving armature.

TRACKING ERROR

In recording, the cutter head travels in a straight line across the disc, but pickups are usually mounted on an arm and cross the record on an arc. There will be considerable distortion in the reproduction if the resultant tracking error is not kept down to a minimum. The error can be reduced to very small proportions by off-setting the pickup head and by mounting the arm so that the needle overhangs the centre of the turntable by the correct amount.

In fact, it is possible to select values which will give two positions of zero error, including the desirable minimum diameter, as shown in the following drawing.

DISTORTION AND TRACKING ERROR

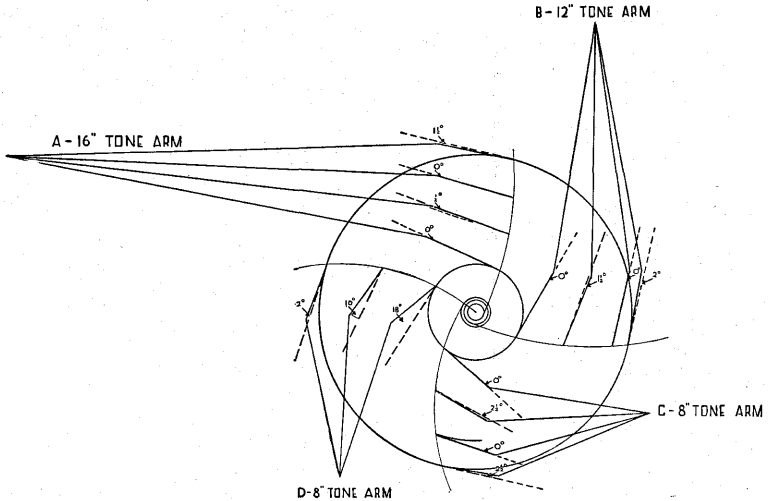

FIG. 79.—Tracking Error.

Drawn by A. HATTON

	Overhang	Offset	Degree of Error			
A —16" Tone Arm	0.27"	12°	0°	1/2°	0°	1 1/2°
B —12" „	0.36"	16°	0°	1 1/2°	0°	2°
C —8" „	0.55"	24°	0°	2 1/2°	0°	3°
D —8" „	Nil	24°	18°	10°		2°

A, B & C—Values for minimum error, for groove diameters of 3 1/2" to 12".

D=Amount of tracking error with 8" tone arm without overhang.

The length of the arm is the distance from the pivot to the needle point, and the tracking error is naturally reduced by lengthening the arm. The overhang is the distance between the centre of the turntable and the needle point when the pickup arm is swung across the centre. The importance of overhang is shown by 79/D, where the 8" arm C is mounted with the needle point reaching the spindle centre resulting in 18 degrees of error. This would cause audible distortion and excessive record wear.

The correct offset angle for any length of arm is easily found. The required overhang is inversely proportional to the tone arm length as shown at A, B and C. Thus a 10" arm would have 0.44" overhang, and the angle is the one giving zero error at the inside diameter of 3 1/2".

The error is of course zero when the line joining the pivot to the needle point is at right angles to a line from needle point to the centre spindle.

DISTORTION FROM OFFSET ANGLE

It is pointed out by W. J. Lloyd in his paper on "Factors in the Reproduction of Gramophone Records" that even the offset angle can cause trouble, as follows :—

The disc in moving drags the pick-up head forward. The line of action of this force passes outside the vertical pivot and produces a torque, which tends to move the pick-up toward the centre of the disc, causing an extra pressure on the inner wall of the groove. Such a pressure is reflected into the pick-up movement, causing its normal zero position to be shifted. If, therefore, any non-linearity is present in the pick-up movement it is made more apparent by this extra bias.

It is advisable to use the longest tone arm possible, and so reduce the offset angle and tracking error as much as possible.

TONE ARM DISTORTION

Any undue friction or stiffness in the lateral movement of the tone arm will cause bias in the pick-up movement and distortion in the reproduction ; effects which are accentuated in the modern lightweight pick-up compared with a blunderbuss.

The tone arm in some autochange machines has to operate several levers, resulting in sluggish movement.

Replacing the heavy pick-up usually fitted to such equipment by a modern lightweight may result in severe distortion, especially towards the centre of the record. The intermodulation product of such distortion would be still more exposed by the use of wide response amplifier and speaker systems.

FAULTS

It is not proposed here to discuss distortion resulting from faulty material, apart from drawing attention to the fact that the needle and armature of a pick-up must be correctly located in the magnetic gap otherwise the uneven flux density cut by the lateral movement will cause non-linearity and severe distortion.

"TRACING" DISTORTION

This covers all the difficulties of the needle in truly following the wave formations in the groove. The main characteristic is that the armature will always prefer to vibrate at its own natural frequency, and its reluctance to operate over a wide frequency range is progressively overcome by reducing the lateral stiffness.

FLUTTER

Whereas wow is the term used to describe slow changes of pitch, occurring up to about ten times per second and easily noticed by the ear, flutter refers to rapid changes which are difficult to detect and are more usually associated with other recording systems, such as variations at 96 c/s with cinema reproduction.

CHAPTER 29

SURFACE AND MOTOR NOISE

The tests described in this chapter were undertaken to ascertain to what extent the various noises associated with record reproduction are affected by choice of equipment.

The suggestion that a loudspeaker may be partly responsible for prominent needle scratch was first made to the writer by Mr. Goodsell of Brighton—a keen searcher for truth in reproduction. Mr. Goodsell was making a Northerner welcome in the South by demonstrating to me the superiority of a certain loudspeaker over one of mine, and he concluded by stating that needle scratch was unusually quiet on the unit in question.

It is very easy to run into error in making such comparisons by mistaking efficiency for accentuation of scratch.

When surface noise is reproduced at a higher volume it takes on a different character to the ear compared with lower volume level, and this adds to the deception if the volume coming out of the speaker is not equalised. These remarks apply to the comparison of pick-ups as well as loudspeakers; the volume control should be turned up instantly when switching over to an instrument with lower output due to lower overall efficiency.

This immediate problem was solved for us by the Decca people, who very kindly sent us half a dozen special discs with a section of recording of 1,000 cycle pure tone followed by a section of groove cut without modulation. We were then able to approximate the volume level from each speaker by means of the pure tone, and examine the surface noise from the plain grooves.

METHOD OF TEST

The tests were carried out under live room conditions, using an audio-frequency analyser along with a sound-level meter, the level being set at 70 db at 1,000 cycles in each case. The frequency range covered by the analyser was 25 to 7,500 cycles.

The most surprising outcome of the tests was the high level of noise found in the bass from vibration of gramophone motor, turntable rumble and mains hum, when using average equipment. The actual sound level of these L.F. background noises is generally higher than the level of surface noise from records, and the reason they are tolerated so readily is the comparatively low sensitivity of hearing at such frequencies at very low volume.¹ Nevertheless, there is always a cleaner background to record reproduction when equipment is used which is entirely free from these noises, for instance a

¹ This background noise level is of course low when compared with 5 or 10 watts of music.

recording-type turntable. The steps which may be taken to prevent vibration and flutter in recording are typified by the weight of the 17½" turntable and 16¼" diameter friction wheel used in B.B.C. equipment, the two discs between them weighing 79 lb.

DETAILS OF TESTS

The first test was made with an old portable acoustic gramophone.

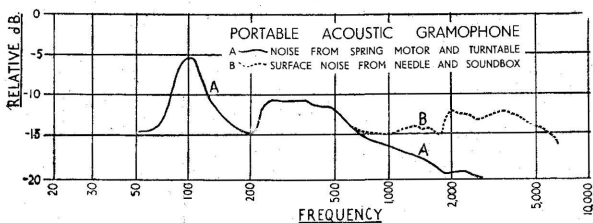

FIG. 80.—Analysis of surface and motor noise from portable gramophone.

There was considerable rumble from the spring-driven turntable, peaking at 100 cycles. A good deal of the surface noise shown at B came directly from the needle and record, and the curve in no way reflects the actual response range of the instrument. A very heavy pick-up or soundbox may have a mechanical impedance which is as high as the mechanical impedance of the record. This will cause vibrations of the disc which are radiated as sound in the surrounding air. In the present case the weight on the needle was about 5½ oz. ; quite sufficient to make the record perform like a flat loudspeaker diaphragm.

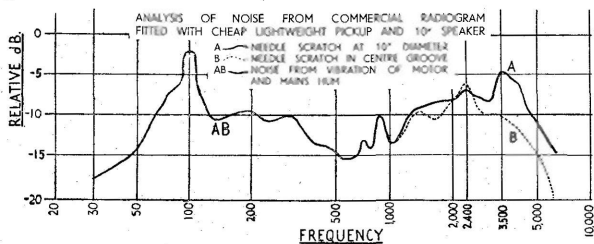

FIG. 81.—Commercial radiogram.

The absence of any peak at 50 cycles in Fig. 81 is mainly due to the use of medium impedance pick-up without transformer. The peak of surface noise occurs at 3,500 c.p.s., falling to 2,400 cycles on centre groove, and the drop at 5,000 cycles is the result of tone control which is normal commercial practice.

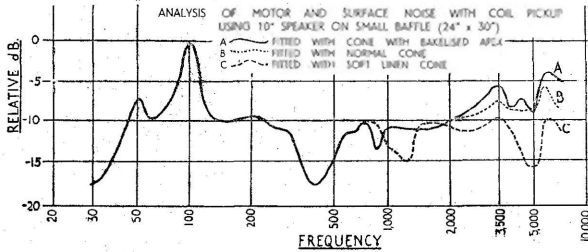

FIG. 82.—Effect of change of cone.

The tests of Fig. 82 were taken with wide response equipment and moving coil pick-up, the 10" units having a magnet of 12,500 lines flux density. The reduced peak of hum and noise at 50 cycles is due to small size of baffle. The curves A, B and C show the effect of different types of cone on surface noise, the level of volume being set at 70 db at 1,000 c.p.s. in each case. The cone A is one which is designed to give a rising characteristic in the treble, whereas the frequency response of cone B is level to about 6,000 c.p.s. and then falls off gradually. Cone C is an experimental type in doped cotton which is normally considered lacking in top response.

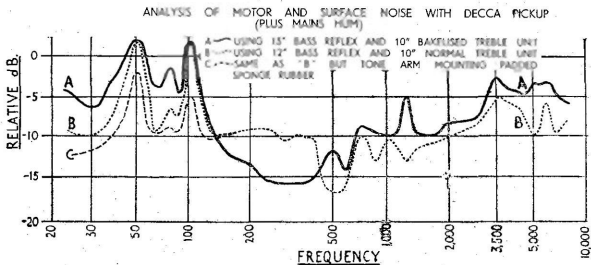

FIG. 83.—Effect of improved L.F. response, and reduced tone arm vibration, with wide range equipment.

This is probably the most interesting of all the tests in the series. To deal first with the bass, curve A clearly shows the effect of improved efficiency from 15" unit in 9 cu. ft. reflex, although a good deal of the hum at 50 cycles was inductive, being picked up by unshielded pick-up transformer. Curve B also shows improved L.F. efficiency of 12" unit in reflex compared with the small baffle and .10" unit of the previous diagram Fig. 82.

For curve C the pick-up arm was partly isolated from vibration of motor by pads of sponge rubber, resulting in a drop of 4 db at 50 cycles and 7 db at 100 cycles in the speaker output. This shows that motor and turntable vibrations are transmitted via mounting board and tone arm to the pick-up head, to be reproduced in the loudspeaker if it responds at the frequencies involved.

As regards the needle scratch of Fig. 83, the analysis is in accordance with expectations. Curve A represents the output from a 10" unit mounted on a small open baffle with corner reflections, using a bakelised cone. Curve B is a normal cone which is considered to have a smooth response with no prominent peaks, the unit being mounted in a corner cabinet. Both speakers were fitted with cloth surround to cone, and magnets of 14,000 lines on one inch centre pole.

SUMMARY

No importance is attached to the obvious conclusion that improved efficiency and wide response in a loudspeaker will increase the surface noise heard and expose rumble or hum in the bass. This was already well known. Nevertheless these points do help to confirm the general truthfulness of the curves shown.

The curves should be used for comparison only, as no accuracy of sound level can be claimed under live room conditions. Also, the setting of db level at 1,000 cycles does not ensure absolute equality owing to effect of speaker resonance points, which may occur at this frequency.

The main deductions are as follows :—

1. If you connect up a batch of pick-ups of different types to reproduce needle scratch, and switch from one to another by the A—B method (to use a pithy American expression) you will notice a difference in general pitch with each change. This is apparently due to the fact that scratch reaches the highest frequencies, and each pick-up colours the output by a rise in output in the region of its own natural resonance. The differences are not easy to detect when a modulated groove is played, unless the music is very quiet.
2. The same test with a batch of different types of loudspeaker (from one pick-up) also reveals differences depending mainly on the frequency range of the speaker.
3. It has not been found possible to trace through needle scratch the sharp peaks which occur at individual frequencies in most loudspeakers in the upper register when fed by a pure tone from oscillator. It appears that there is not sufficient energy at a single frequency in such surface noise to cause each sharply defined resonance to build up. On the other hand, a cone with a rising characteristic over a band of frequencies would give greater output of signals and surface noise in that region.

4. In the writer's opinion a scratch filter does not offer a solution of the problem, for the following reasons:—
1. Scratch is a random noise containing an infinite number of sum and difference frequencies up to the highest limits passed by the equipment.
 2. Peaks vary in frequency, and the general pitch of the noise goes down as the pick-up approaches the centre of the disc. It would be necessary to "tune" the filter frequently for maximum effect.
 3. Cutting out a slice of scratch also removes a slice of music or whatever is being reproduced.
- It is nevertheless admitted that a scratch filter is a palliative in some cases.
5. The following oscillograms (Fig. 83/1) show the spectrum of surface noise up to 30,000 cycles, with Decca pick-up in a normal unmodulated groove at wide and narrow diameters.

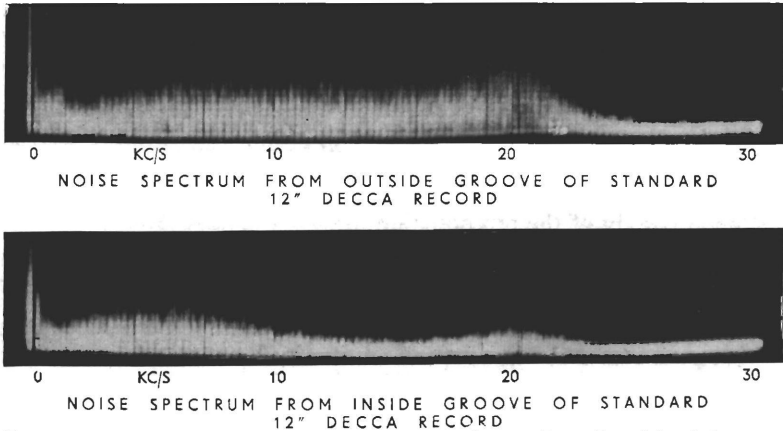

FIG. 83/1.

Courtesy Decca Record Co., Ltd.

Note the general drop in frequency at the slower surface speed of inside groove.

6. That scratch frequencies reach very high limits may be observed by listening to the highest frequencies when changing to a pick-up or loud speaker with very wide response. Such a listening test offers a rough and ready comparison of H.F. response of different reproducers. Assuming that some of the particles of which a disc is composed are .002" in diameter, this would approximate the wavelength of a tone of 20,000 c.p.s. at 10 inches diameter of record. Although such high frequencies are inaudible to normal ears, difference tones are produced and heard.

7. As needle scratch originates in the disc, the obvious remedy is in smoother records. The best treatment for the disease is a correctly fitting stylus and top cut to taste. A falling characteristic is to be desired, as a sharp cut-off often produces a peak just below the cut-off frequency which may make the remedy worse than the disease.
8. Any cone material of high viscosity, similar to Fig. 82(c), or any needle of the nature of fibre, will result in low needle scratch accompanied by poor H.F. response. Of magic there is none

VIBRATION, HUM AND RUMBLE

As a result of the L.F. peaks found in the previous four diagrams, an investigation of the cause was carried out. At the outset, it should be stressed that the peaks look much worse on paper than they sound to the ear, and in fairness to makers of turntables and motors it is admitted that the 100 cycle hump is partly due to mains hum and the 50 cycle note is mostly picked up by induction. The rumble of Figs. 80 and 81 made itself heard, but it was necessary to listen very closely to notice noise of 82. In the case of Fig. 83 the 50 cycle hum was noticeable between items.

The interesting point about these low frequency "noises" is that many people fail to notice them, or soon become accustomed to them at medium power, and although the background noise may not be recognised during musical items its complete elimination cleans up the general quality of the reproduction.

A strange fact is that some people change to a more efficient L.F. speaker system and hear hum which was not previously audible, and blame the new system.

Where the pick-up and loudspeaker are mounted in the same cabinet with good bass output, it is possible to have acoustic feedback which completely ruins the quality. The following details may help in locating and subduing the excessive vibration in such cases.

The first diagram (Fig. 84) shows the vibration readings at 8" radius on mounting board with two typical motors, plus an extra reading taken on side of cabinet. Both machines are centre-drive types.

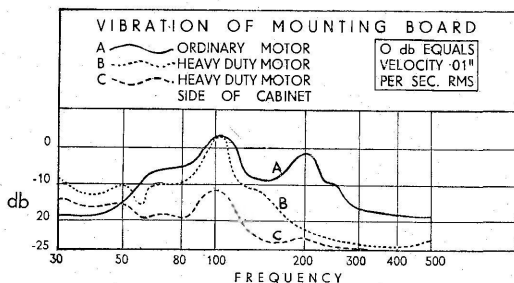

FIG. 84.— Gramophone Motor vibrations.

Curve A was taken on the commercial radiogram used for Fig. 81, and curve B involved a better class two-speed motor ($33\frac{1}{3}$ and 78 r.p.m.) with the turntable running at the higher speed. It is computed that vibration below the level of -10 db on the graph would not appreciably affect loudspeaker output. Curve C demonstrates that most of the motor board vibration could be avoided by mounting the tone arm on a bracket fixed to the cabinet side and isolated from the actual mounting board.

It was found that vibration varied considerably even on the mounting board, and the best position for the tone arm pivot does not appear to be always selected.

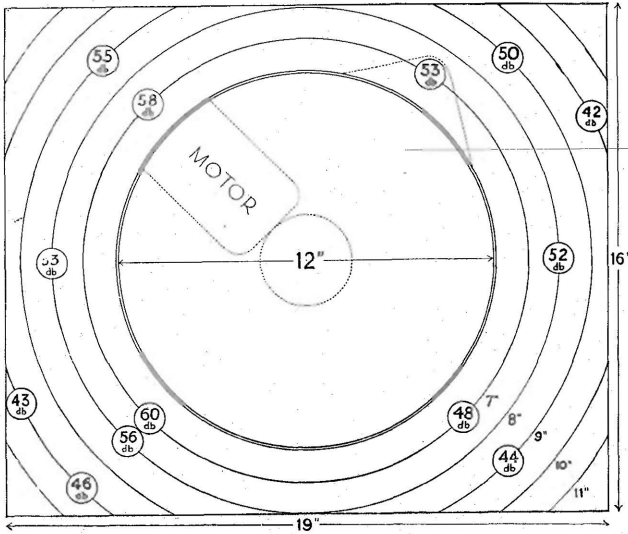

FIG. 85.—Vibration readings at different locations on motor board, $\frac{3}{8}$ in. plywood. Below 46 db considered harmless.

It will be observed that the vibration diminishes towards the edge of the panel with minimum readings where supported by side members. The metal mounting location for pick-up arm gave a reading of 53 db. Note.—Spring or rubber mounting of motor and turntable unit would of course reduce vibration of mounting board.

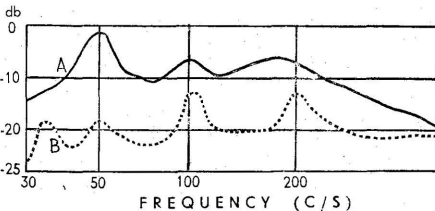

FIG. 86.—Vibrations at 8 in. radius.

- A. Cheap rim-drive motor.
- B. High-class rim-drive motor.

With rim drives, the vibrations are spread over a wider frequency range.

In the case of 86A it was not necessary to connect the machine to any amplifier to hear the noise and rumble. The acoustic performance at first hand was ample. The unit spoke for itself.

The motor and turntable outfit of Curve B gave excellent results and no trace of rumble or vibration could be heard through the loud-speaker.

The price of this machine is about 5 times as much as the type 86A.

The total average vibration readings of the various turntable drives tested come out as follows :—

Cheap rim drive	78 r.p.m.	63 db.
Ordinary centre drive	78 r.p.m.	56 db.
Heavy duty centre drive	78 r.p.m.	50 db.
Heavy duty centre drive	33 $\frac{1}{3}$ r.p.m.	45 db.
High-class rim drive	78 r.p.m.	42 db.
Recording Type	no measurable vibration.	

For record reproduction a level of 46 db or less is considered quite satisfactory, and 50 db is passable.

RECORD AND NEEDLE WEAR

It should always be remembered that vibration of turntable or pick-up mounting tends to increase the rate of wear on record and stylus. It is therefore worth while to achieve the smoothest possible running, for reasons of economy as well as acoustics.

VIBRATION FROM AMPLIFIER

Amplifier hum is all too prevalent in loudspeaker output. The fact that hum may be transmitted mechanically through the cabinet structure and turntable to the pick-up was brought home to the writer recently during a test of some new microgroove records. A crystal pick-up was being used, with maximum output in the 40-50 cycle region, and it was impossible to administer any bass lift without introducing terrific hum to the reproduction. After wrongly suspecting American recordings, the pick-up was by chance left resting on a stationary record with the gramophone motor switched off, but the hum from the loudspeaker remained.

This is a form of mechanical and acoustic feedback which may be transmitted through the cabinet structure and even through the floor of the room if the loudspeaker is housed in a separate cabinet. The resonance is more likely to build up in a type of pick-up with good bass response than in one which requires bass lift to equalise normal characteristics.

It is agreed that complete absence of hum in amplifiers is desirable; it is not always possible.

CHAPTER 30

PICK-UPS

EARLY PICK-UP DESIGN

In the early days of the pick-up, most designs were based on the balanced armature principle and belonged to the blunderbuss variety. Perhaps the simplest and quickest way to appreciate the virtues of modern pick-ups is to examine the faults and shortcomings of the old ones. In this way we can virtually describe many living bodies by one post-mortem, as the fundamentals of good design do not vary. Fig. 87 is a typical schematic of early types :—

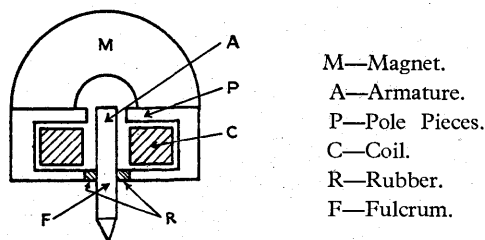

FIG. 87.—Diagram of early magnetic pick-up.

Before opening fire on the target, let us admit one supreme virtue. The voltage output and impedance of the coil could be arranged to work straight into the first valve of the amplifier, and the user was spared all the fiddling with pre-amps and transformers which is so often necessary before a modern pick-up will condescend to give of its best. The voltage output of a magnetic pick-up is entirely dependent on the number of turns on the coil, the mass of iron in the armature system, and the magnetic flux across the gap. It follows therefore that the output goes down as the mass is reduced, and the smaller coil has a lower impedance.

The faults may be summarised as follows :—

1. Heavy rubber damping at R, required to centre the armature between pole faces.
2. Lateral stiffness as a result of 1, causing rapid record wear.
3. Excessive weight required to hold needle in groove, as a result of 1 and 2.
4. Too much fore and aft freedom of movement.
5. Insufficient vertical compliance causing wear from pinch effect.
6. Mass of needle and armature giving resonance in middle or upper middle register, with free end of needle holder vibrating like one limb of a tuning fork.

7. Heavy rubber damping transmitting resonance to tone arm in the bass.
8. High mechanical impedance causing vibration of record with musical "chatter."

Apart from the above, the pick-ups seem to have been fairly good! Round about 1933 there arose from the welter of heavy-weights two medium weights of outstanding design and performance. These were the B.T.H. and Burndept needle armature types, and it is no exaggeration to say that they were well ahead of their time. It is not possible to give any details of the Burndept model as the original firm is no longer in existence. The B.T.H. Co. have furnished drawings and response curves of their model. The response was almost fully maintained up to 7,000 c.p.s. and the main resonance appears to have been located around 6,000 cycles, which is pretty high for 1933. The weight on needle point was approximately 2 ozs. which is very low for the same period. Although no longer in production, some of these pick-ups are still in use by the B.B.C., and many early users of the needle armature types will agree that they gave us a foretaste of the resonance-free reproduction which has followed improvements in other sections of the chain.

VOLTAGE, IMPEDANCE AND HUM

The variations in voltage output and impedance of pick-ups are enormous, and it is almost impossible to design a single amplifier which will give reasonable matching and gain to all the types at present on the market. It is advisable to follow the maker's instructions when installing a pick-up, as results will suffer if input matching is at fault.

A pick-up of medium impedance, in the region of 2,000 to 5,000 ohms, can often be used without an input transformer and with complete freedom from inductive collection of hum. A model with extremely low output will require very high ratio of transformer to increase the voltage, resulting in high impedance lines which are very sensitive to hum. The writer has one instrument which could almost be guaranteed to pick up the hum from a piece of Gorgonzola. In severe cases, screened leads and shielded transformers do not offer adequate protection and it may be necessary to try many positions before trouble is overcome.

FREQUENCY RESPONSE

The four main systems for converting mechanical movement into electrical signals are the following:—

1. Magnetic.
2. Dynamic (Moving-coil or Ribbon).

3. Crystal.
4. Electronic.

In the magnetic and dynamic systems the voltage output is proportional to the velocity. The response below the change to constant amplitude is therefore the same as the record, and it is necessary to apply bass lift to the reproduction to equalise the characteristic.

On the other hand, the response of crystal and electronic systems is proportional to the displacement, and the L.F. output is accentuated. This is more or less balanced by the recording characteristic, and bass lift in the reproducing channel is not required.

The response of these systems falls off in the upper frequencies and some equalising network is called for. A crystal with a normal cut-off at 8 Kc/s may be extended to 15 Kc/s with a suitable network.

VARIOUS SYSTEMS DESCRIBED

MAGNETIC This is still the most widely used type of pick-up. In some recent designs the fulcrum has been placed at one end of the armature so that the vibrations near the stylus tip are used to generate the voltage in the coil, thus reducing the danger of non-linearity.

There are, in fact, modern designs in which the stylus is reduced to little more than the tip.

MOVING COIL Although the moving coil pick-up has not had the same devastating effect on rival systems as the moving coil speaker had, it is capable of giving excellent results.

RIBBON Being an ultra-lightweight, the voltage output is extremely low and a special stage of pre-amplification is usually required, with precautions against hum. There is a light and airy character about the reproduction of soft passages of music with this type of pick-up which is very attractive, giving the effect of not actually listening to a pick-up.

CRYSTAL Most of the objections to the crystal pick-up have been removed by the modern lightweight version. Vertical inertia has been improved, and the type still has the advantage of adequate voltage output and full bass response. A suitable resistance, or a full equalising circuit is required for best possible results.

ELECTRONIC An electronic pick-up is one in which the output is generated by the motion of an electrode in a vacuum tube (or valve). The anode is the movable element, and the voltage is generated by the change in distance between the cathode and the anode.

R.C.A. have recently introduced a pick-up of this type, suitable for measuring vibrations up to 12,000 c.p.s.

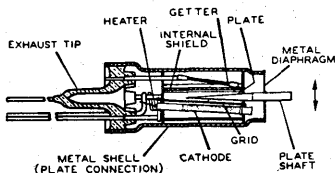

Courtesy R.C.A.

FIG. 87/I.—Electronic Pick-up.

The entire valve weighs only $\frac{1}{16}$ of an ounce, is just over $1\frac{1}{2}$ inches long and has a diameter of $\frac{5}{16}$ inch.

The operating conditions are 300 volts D.C. at 5 ma and 6.3 volts A.C. or D.C. at 0.15 Ampere. The mechanical impedance is exceedingly small and the instrument can be adapted for wide frequency range reproduction of records by soldering a stylus to the plate shaft.

TURNTABLES

Several types of modern pick-up require a non-magnetic turntable, otherwise there is pull on the pick-up head. The trouble can be alleviated with a steel turntable by raising the height of the pick-up mounting and placing a disc of plywood underneath the record.

MODERN DESIGN

The pick-up is a transducer for changing mechanical movements into electrical signals, whereas a loudspeaker is a transducer which functions in the reverse way by changing signals into movement. The loudspeaker, working at the output of the chain, has to deal with large amplitudes, and this accounts for the supremacy of the moving coil system. The pick-up, however, has only small amplitudes to cope with, and various systems can be employed provided the fundamentals of good design are applied. Even so, the moving coil pick-up still justifies its comparatively high price.

These fundamentals may be summarised as follows :

1. Lightweight.
2. Free lateral movement of stylus.
3. Adequate vertical compliance without generating voltage.
4. No fore and aft freedom of movement.
5. High natural resonance.
6. Low tone-arm resonance.
7. No lateral restraint in tone-arm movement.

In order to reduce mass and raise the resonance it has been necessary to dispense with needle holder and screw, and much ingenuity is

displayed in the methods devised for fixing the needle. The following diagrams show some of the systems in use during 1949 :

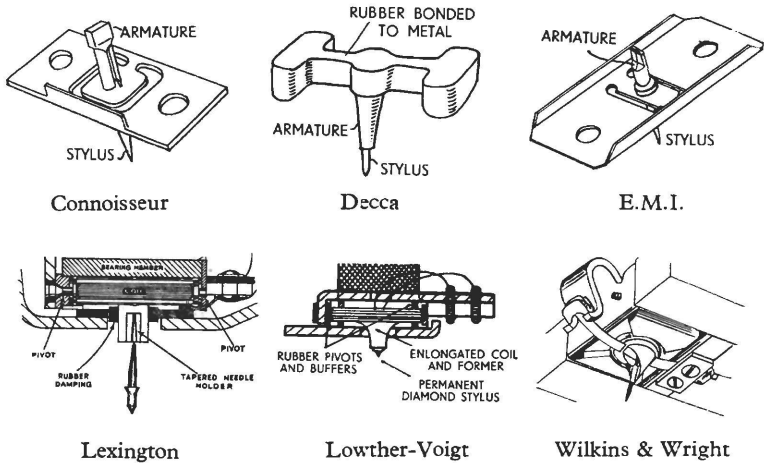

FIG. 88.—Various needle and armature assemblies.

Very smooth tone-arm movement free from friction or restraint is now a necessary feature in any first-class pick-up mounting. The Leak pivoting system is illustrated in the following photograph :

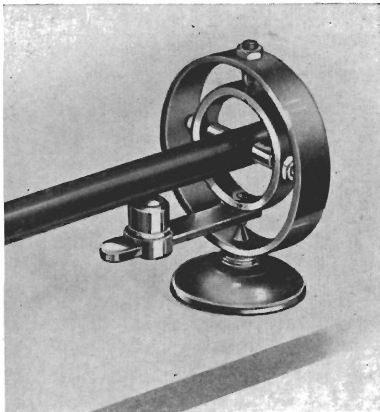

FIG. 89.
Tone-arm mounting used for Leak moving coil pick-up.

The movable bearing under the arm permits adjustment of weight on record down to 5 grammes.

During the last twelve months, further progress has been made in design of crystal and magnetic types and satisfactory tracking at 10 grammes or less is now possible with several models, with improved performance and reduced wear. Interchangeable heads to track at 5-6 grammes on microgroove records are appearing on the market. Rotating heads and interchangeable needles are also in sight, but it is worth while to change the head for maximum results.

FEATHERWEIGHT PICK-UPS

“Here comes the lady—O, so light a foot
Will ne'er wear out the everlasting flint.”
Romeo and Juliet, Act II, Sc. 6.

The reduction in record wear associated with light pressure and lateral freedom has been pointed out in previous chapters. Other benefits with such pick-up movements are low tone-arm resonance and high armature resonance.

The resonance in all modern designs which claim to be first class, whether moving coil, magnetic, crystal or ribbon, has been elevated to the region of 18 Kc. or higher. There are at least four distinct advantages :

1. The resonance is supersonic.
2. The excess wear in the vicinity of resonant frequencies is avoided.
3. Intermodulation effects of resonance are avoided. Damping of resonance at lower frequencies may remove the peak but the intermodulation products remain.
4. The frequency response is extended.

The design of the modern crystal pick-up has been improved by increasing the vertical compliance. A crystal will generate voltage by bending or twisting in any direction. Second harmonic distortion from pinch effect has been serious in heavy crystal pick-ups. Adequate compliance overcomes the generation of voltage in a vertical direction, and the advantages of high output level with ample bass response become available with low rate of wear. The Cosmocord G.P.20 is supplied with replaceable head of lighter weight for microgroove use.

Another featherweight pick-up with interchangeable head is the new magnetic model by Connoisseur, which tracks at 10 grammes at 78 r.p.m. or 5 grammes with microgroove head. The mass of the armature with sapphire has been reduced to 20 milligrammes, with resonance above 20 kc. A replacement needle/armature assembly can be fitted by the user when required.

The above pick-ups are mentioned here because they have been

used a good deal during the course of recent investigations. It is not suggested that other makes with equally attractive features are not available, nor is it suggested that the performance of the good moving coil types (at 78 r.p.m.) has been equalled at a fraction of the price. It remains to be seen how the moving coil pick-ups will be adapted to microgroove working; merely changing the needle does not promise to be a full solution of the problem. The tip radius with microgroove is less than half the standard radius, resulting in much greater pressure at the point of contact with the wall of the groove, which increases the rate of wear and also tends to lower the resonant frequency of the assembly. It is obviously desirable to reduce the weight as much as possible to counter the rise in pressure. Moving coil pick-ups such as the Lowther-Voigt and Leak models are already fitted with means for adjustment of weight.

The term "lightweight pick-up" is in some cases a misnomer, as quite heavy instruments may be designed and adapted to give very light needle pressure, thus ensuring very low and inaudible tone-arm resonance. The counter-balance for reducing weight on needle has in some cases been replaced by adjustable spring tension which enables the user to vary the needle pressure by turning a knob. Although quite effective in use, the spring loading appears to intensify the swish from a non-flat record, and initial experience in manipulating the tone-arm is rather like playing football with a balloon.

GROOVE LOCATION

In order to link discs in sequence or to play excerpts from a record, it is often an advantage to have a groove-locating unit. The following illustration shows the apparatus used by the B.B.C. on 78 r.p.m. recordings, Fig. 90.

With this equipment, it is possible to work to an accuracy of plus or minus half a second, which is equivalent to about half a revolution of the disc. The record is played until the start of modulation, or the beginning of the required excerpt, is heard. The head is then raised by the lever and the vernier is turned to set back the head assembly by a small amount. The pick-up is then ready to be lowered when required. The system also has the advantage of parallel tracking.

At $33\frac{1}{3}$ r.p.m. the accuracy becomes plus or minus one second, which is not considered satisfactory for many purposes; therefore the 78 r.p.m. discs are used for recordings from which excerpts will be required to be broadcast.



From B.B.C. Quarterly, July 1948.

FIG. 90.—Groove-locating unit.

For linking discs at $33\frac{1}{3}$ r.p.m. the groove widening system described in Chapter 24 page 174 is mainly employed.

Another advantage of a groove-locating unit is the mechanism for lowering the pick-up head onto the record. With delicate lightweight pick-ups this is much safer than hand operation, and units are now available which can be used with existing tone arms :—

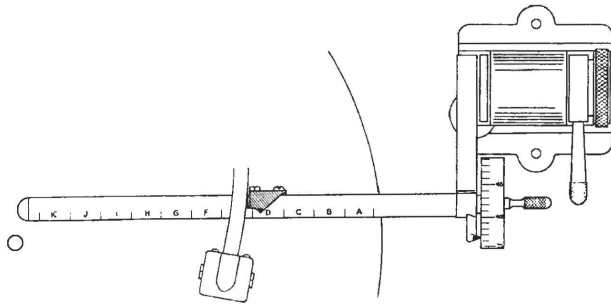

Courtesy Simon Sound Service, London

FIG. 91.—Unit for lowering pick-up and locating groove.

In this apparatus the lowering action is initially coarse to within $\frac{1}{8}$ in. of the record, and the pick-up is brought finally into contact with a vernier movement which engages automatically, thus avoiding possible damage to needle and record.

A new parallel tracking cueing device designed and patented by Decca is illustrated in Fig. 91A.

To cue to an exact point on any record, irrespective of whether it is a true-centred or out-of-centre record, it is only necessary to mark the edge of the record in relation to a mark on the edge of the turntable.



FIG. 91A. Decca parallel tracking cue device, electrically operated by push-buttons.

With the normal groove spacing at 78 r.p.m. it is possible to cue to a syllable or to one note of music. Visual indication on vernier scale provides an easily-read setting to one hundredth of an inch. Any size record up to 18" diameter may be played. The pick-up head is raised and lowered electrically by push-button switches. Action is smooth, positive and silent, the pick-up being muted until actually in contact with the record.

CHAPTER 21

SIGNAL TO NOISE RATIO

This is a factor in all forms of recording, transmission and reproduction of sound :—the higher the ratio, the better the results.

We are all familiar with radio interference from atmospheric, electrical equipment and other transmissions, which can fortunately be swamped by strong signals from a local station. As most of this interference is amplitude modulated, it does not affect transmissions which are frequency modulated, and tests are being carried out by the B.B.C. with F.M. transmissions compared with A.M. over a selected area.

In reproduction intelligibility depends on the signals being heard at a higher sound level than any background noise, say about 20 db minimum difference.

For the enjoyment of music the background noise must be reasonably low, otherwise the volume has to be turned up to an unnatural extent and a deafening pandemonium may result.

FACTORY NOISE

Before installing "Music while you work" in a factory containing a lot of machinery, a reading of average noise level should be taken to avoid possible disappointment with results. A few local tests came out as follows :—

TEXTILE FACTORY

Weaving shed with 140 looms	90 db
" " " 22 "	89 db
Spinning shed 40 x 20 yds.	80 db
Drawing room 40 x 15 "	80 db
Winding room 40 x 15 "	75 db

LOUDSPEAKER WORKS

Cabinet shop near Router	86 db
" " " Saw	82 db
" " Assembly room	60 db
Coil winding close to machine	75 db
" " 6 ft. from machine	66 db

Using the same noise-level indicator, it is found that music reaching the ears at a level of 83 db is very loud, regardless of the size of the room.

It is clear that music could not be enjoyed in the textile factory where the noise level is 75 db or more. It is satisfactory in the cabinet assembly room, and also in the coil-winding department at a distance of 6 ft. or more than a machine, but the operator cannot appreciate what is being played while the machine is running.

NOISES OFF

Nothing is more trying to a sensitive ear than music accompanied by obtruding sounds, such as the bleating of a commentator's voice. The same remarks apply to speech when blurred by background effects. There are even professional stage producers who allow "noises off" to continue during the whole of a scene in competition with the voices of the actors. If the state of the weather is of supreme importance to the plot, it would be better to display a notice "It is still raining" or "It is windier than ever outside" than to assail our ears with needless signal/noise worry. Apart from the occasional unholy alliance of voice and music mentioned above, the B.B.C. generally show restraint in the use of sound effects.

SURFACE NOISE

A background noise of even volume and sound structure is much more tolerable than a sudden or changing sound such as the click of a damaged surface or the swish of a warped record. A comparative table of surface noise levels is given in Chapter 13, based on different disc materials. There is no doubt that the level nature of needle scratch enables us to tuck the sound away to a certain extent and concentrate on the music. When the recording level is increased at frequencies above 3,000 c/s there is a reduction in needle scratch in the reproduction as the response above 3,000 cycles is reduced to balance. In other words, the signal to noise ratio is improved.

MICROGROOVES

The comparatively quiet background which is obtained with vinylite and modifications thereof, such as Geon, results in more startling effects from dust or grit which may find its way into the grooves. Scratches are also serious, and it is wise to handle all L.P.s as if they were valuable photographic negatives.

The necessity for keeping such records clean is much greater than with shellac discs, and the actual cleaning process is more difficult. Methods of cleaning will be found on page 157.

Storage cases without a centre opening are advisable.

MICROGROOVE RECORDING

About the middle of 1948 quite a commotion was caused in America by the introduction of the microgroove long-playing records developed by the Columbia and Philco organisations. A playing time of $22\frac{1}{2}$ minutes from one side of a 12 inch disc is obtained by using $33\frac{1}{3}$ r.p.m. instead of the usual 78 r.p.m., with grooves cut 224 to 300 to the inch instead of the usual 96 grooves per inch. Nonbreakable vinylite discs give a low surface noise which is necessary on account of the lower recording level. The groove is .003 in. wide and requires a reproducing stylus with a radius of .001 in. as shown in Fig. 63B, Chapter 26, with a weight of about $\frac{1}{8}$ oz. on the record.

In view of the slow speed, recording is taken to a minimum groove diameter of $4\frac{3}{4}$ inches, compared with the usual $3\frac{1}{2}$ inches limit at 78 r.p.m. The price of the records is as follows :

12 in. Masterworks	24/-
10 in. Masterworks	19/-
10 in. Popular	14/-

It is therefore possible to buy a complete symphony or concerto on one 12 in. record, which formerly would have required an album of about 5 records.

The following diagram gives a typical recording characteristic as used in microgroove records, Fig. 91B :

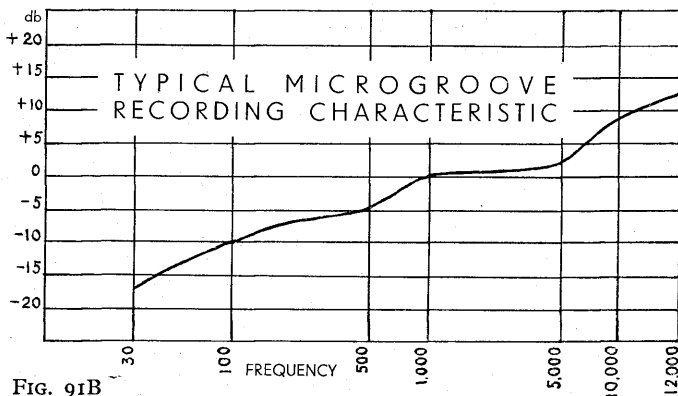

FIG. 91B

I understand that the Decca "London" characteristic is similar to American practice, but the rise is continued up to 16 kc.

This is quite different from the usual British 78 r.p.m. characteristic, and the response must be equalised in the reproducing equipment for satisfactory results. The correction would normally be applied in the pre-amp or in the tone controls of the amplifier. Where existing equipment is not easily adapted to give the required falling characteristic, a method of tone control may be used in the loudspeaker circuit as described in Chapter 18, Crossover Networks.

A falling characteristic of about 3 db per octave above 500 c.p.s. is achieved by inserting inductance in the speech coil circuit as follows:

Up to	.50	mH	with	3	ohm	speakers
„	„	1.00	„	„	6	„
„	„	2.00	„	„	12-15	„

This arrangement works quite well.

The records give very good results, due mainly to the improved tracing achieved by the very fine stylus point. Even so, I hear of adverse criticism of microgroove recordings by some of our professional scribes. I am unable to understand this, unless they use a pen nib as a stylus. Through the kind offices of my correspondent, Mr. DeVere of Los Angeles, Columbia have very kindly sent me a batch of L.P. records for test, and Astatic have sent me a set of pick-ups with equalising network. These gestures are highly appreciated, because, in spite of the fact that I ship a fair bundle of books to New York every month, I have not a dollar to my name. Unfortunately, these lines have to go to the printers before thorough tests can be made, but it is clear that first-rate reproduction is possible with reasonable equalisation.

In spite of the sweeping success of microgroove recordings of classical music in America, no long-playing record system is as yet available in this country (A.D. 1950, fifth month). The question is not "Will L.P. records be introduced here?" It is only "*When* will they come?" It is already an open secret that large quantities of microgroove records are being produced here for the dollar market. There would, of course, be no point in putting them on the British

market until adequate supplies of two-speed turntables and microgroove pick-ups are also available.

RECORD WEAR

The next three photomicrographs show the result of tests for wear on microgroove records manufactured in London by the Decca Company under the trade mark of the "London" label for the London Gramophone Company of New York. The disc material produced by Decca is known as Geon, the surface of which seems to set harder than the normal plastic surface of vinylite. This may account for the remarkably low rate of wear. The pick-up used for these tests was the Cosmocord G.P.20 with microgroove head tracking at 5 gr., with sapphire tip of .001" radius.

These photographs are so remarkable that a brief description of their evolution will not be out of place. I selected a piano record for test because I was curious to see what a piano recording looks like after being magnified 200 times.

The absence of high overtones is probably due to the fact that overtones in the sound from a piano are relatively weak compared with the H.F. vibrations of cymbals, which are generally selected for this type of photograph. I played one portion of the record 50 times before sending it to Mr. Watts to be photographed, but he was unable to find any trace of wear, and he replayed the section a further 250 times to obtain the results shown in the photographs, which speak for themselves. Figures 91C and 91D.

The next photograph, 91E, shows a similar record made in Geon by Decca, but this time the sound includes cymbals and orchestra in a recording of Petrouchka. The surface speed is about 14"/sec. Therefore $\frac{1}{4}$ " wavelength on the photomicrograph represents approximately 12,000 c.p.s. The record was played 50 times before this photograph was taken. The wear is more pronounced than the piano test, due to the higher frequencies involved, but it is still very slight and practically inaudible.

It is clear that a long life may be expected with good microgroove records, provided that a smoothly running turntable, freely mounted tone-arm, and compliant lightweight pick-up are used.

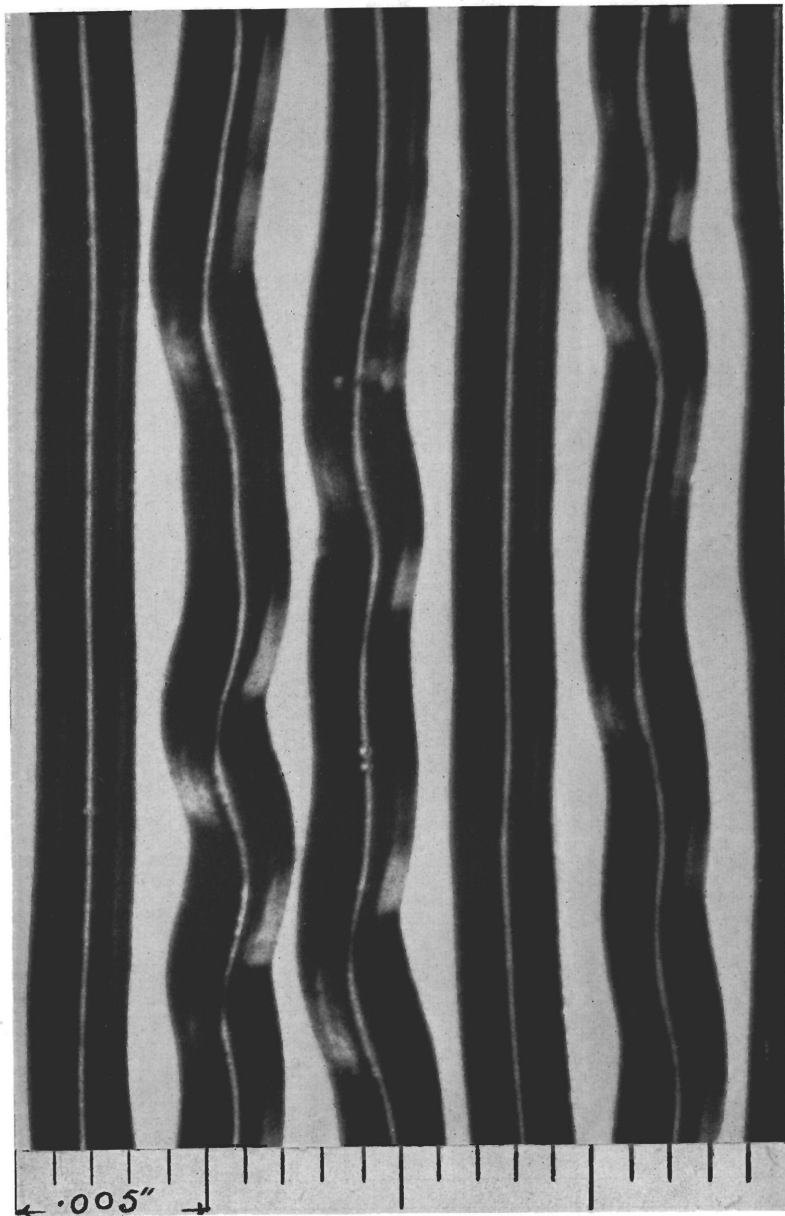

Photo by C. E. WATTS.

FIG. 91C.—New Geon microgroove recording of piano, made by Decca.

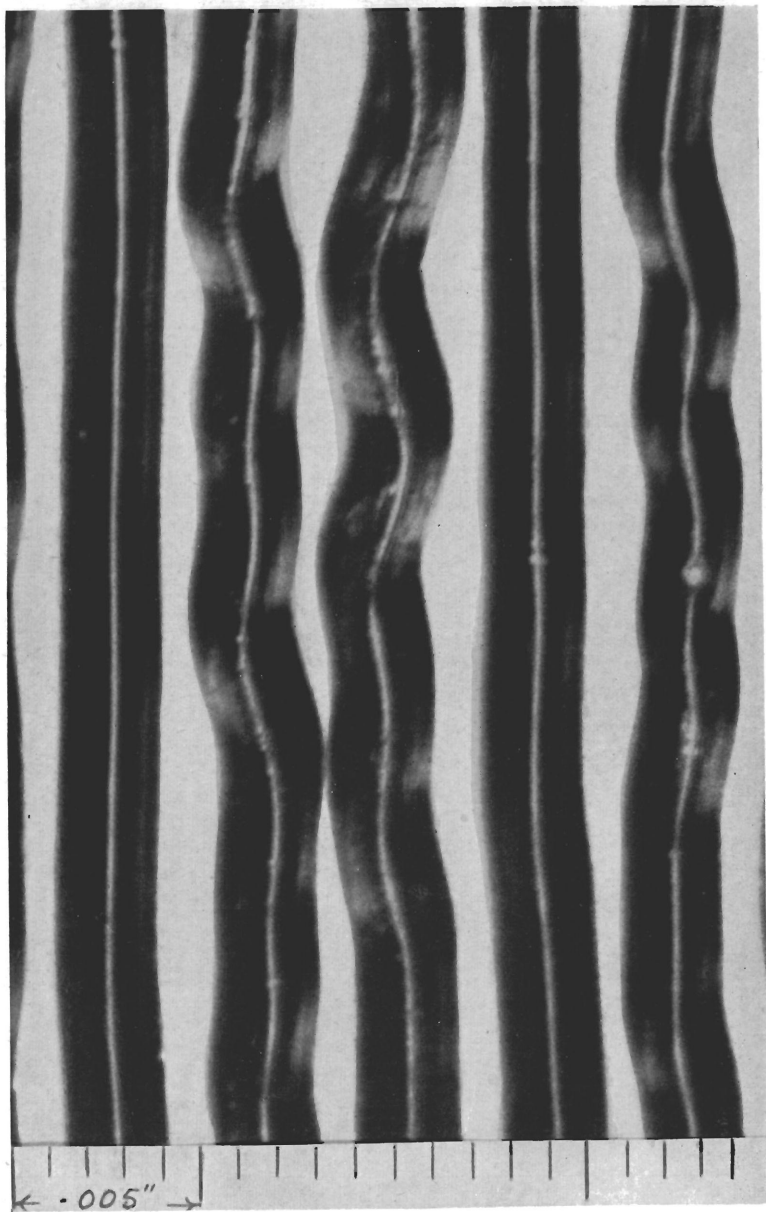

Photo by C. E. WATTS.

FIG. 91D.—Same record as 91C after 300 playings with crystal pick-up and sapphire, tracking at 5 grammes.



Photo by C. E. WATTS.

FIG. 91D.—“London” Microgroove recording (Petrouchka) after *fifty* playings with crystal pick-up and sapphire point.

The technical difficulties involved in the production of microgroove records must be very much greater than with ordinary records, owing to the finer grooves and lower recording level. It follows that higher standards in reproducing equipment are also necessary. The Connoisseur two-speed motor, costing £13 15s. plus purchase tax, has been used in these tests and has proved entirely satisfactory.

NEEDLE WEAR

As regards needle wear, it is logical to assume that conditions which produce the very slow rate of record wear shown in Fig. 91D will also result in a low rate of needle wear. The ideal point is, of course, the diamond. The toughness of tungsten-carbide should be an attractive quality in a fine microgroove point. Nevertheless, the writer's experience with sapphire tips on microgroove vinylite records has been entirely satisfactory, and rate of wear no worse than that produced by 78 r.p.m. shellac should be possible.

This experience does not agree with reports on fine sapphire points received from America, but it is impossible to compare results without taking into account the equipment used : pick-up, tone arm, motor, etc.

MICROGROOVE QUALITY

I suggest that anyone who doubts the superb quality which is possible with microgroove recording should hear the Decca "Petrouchka" record properly reproduced; or alternatively the Columbia record of Handel's "Royal Fireworks" Suite. In both cases the quality is really above criticism.

The next two photomicrographs are included to show the improved surface which appears on recent Columbia microgroove pressings.

The first picture, 91F, shows an early vinylite microgroove pressing with confused wave form probably due to cutting on a nitro-cellulose or similar blank. This could now be classed as old, in spite of the short time which has elapsed since L.P. records were introduced. This particular recording caused unusual tracking difficulties due to over-modulation.

The second photograph, 91G, represents a recent Columbia record in new condition. The clean grooves are very much superior to the previous photograph. Probably cut in wax.

There is little doubt that many of the complaints which have been made about L.P. records were related to faults which are slowly but surely being eliminated.

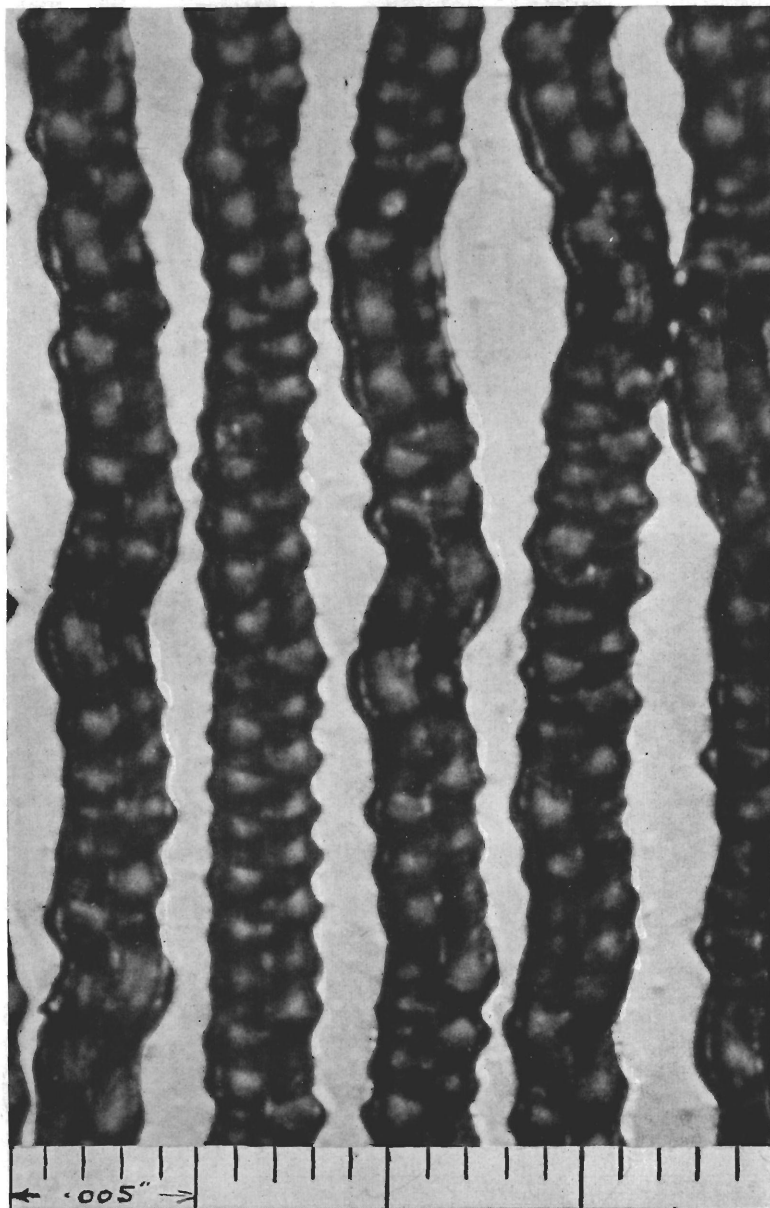

Photo by C. E. WATTS.

FIG. 91F.—Photomicrograph of early microgroove record showing plastic nature of vinyl pressing, with rough shoulders to the grooves and heavy modulation.

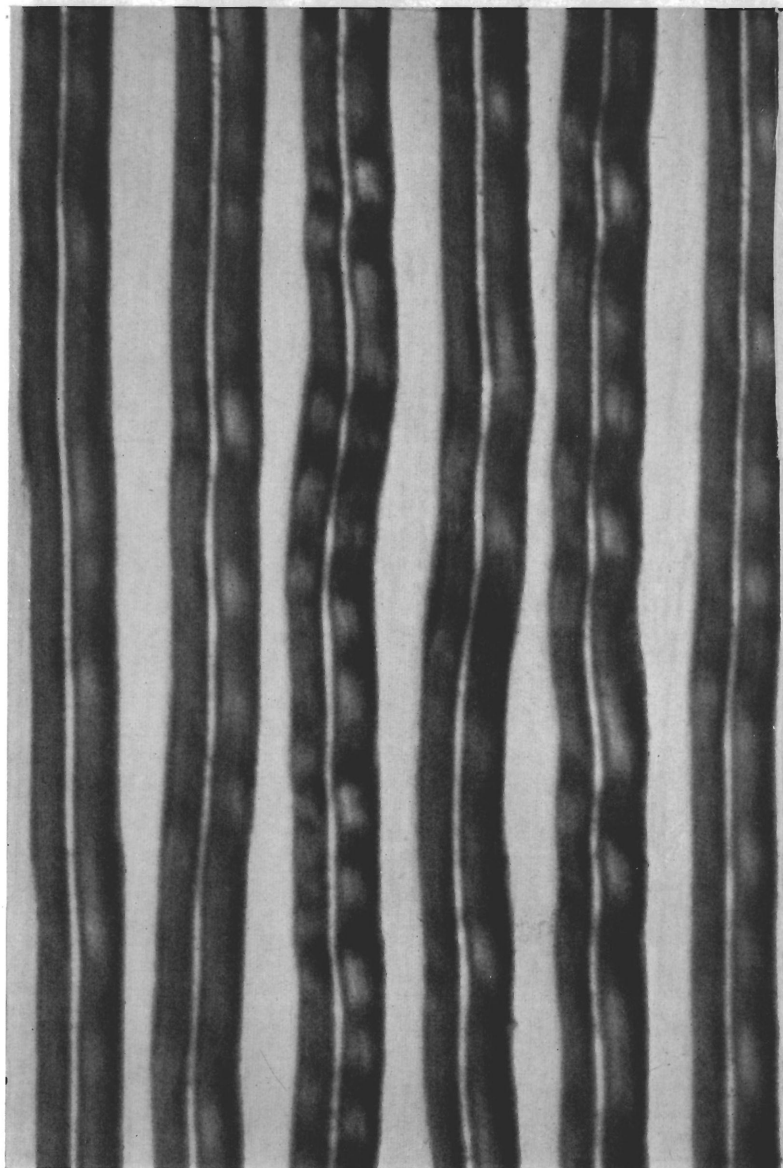

Photo by C. E. WATTS

FIG. 91G.—Photograph of recent Columbia microgroove record showing clean surface, with absence of previous “plum pudding” effect.

Early in 1949 yet another new system made its appearance in America, introduced by R.C.A. Victor and using 7 inch discs operating at 45 r.p.m. The records are in wafer-thin, extremely light, non-breakable vinyl plastic with $1\frac{1}{2}$ inch centre spindle hole, and the playing time is 5 minutes 15 seconds per side. There can be no doubt that the design and refinement of a new type of record and record-player must take a long time, and it is claimed by R.C.A. that this new system is the climax to more than 10 years of research. The approach to the problem has been along different lines from those adopted by Columbia, although running concurrently. The heart of the R.C.A. instrument is the automatic record changer mechanism located in the large $1\frac{1}{2}$ inch diameter centre spindle. This houses a trigger-fast drop mechanism, resulting in noiseless change of records in about 3 seconds from groove to groove. The musical break varies according to start and finish of modulation.



Holds eight records giving 42 minutes of continuous playing.

FIG. 92.—R.C.A. 7 in. Record Player.

The small tone arm and pick-up exert a pressure of only 5 grammes on the record, and a fine sapphire needle is used.

ELECTRONIC SOUND

It is stated in one scientific book on Sound that investigation has proved that the majority of the musical instruments in use today are of imperfect design, and that scientists would in time evolve electronic instruments with perfect tone, and musical giants would write synthetic music composed of sounds hitherto unheard.

When I listen to oboe playing by Leon Goossens, a Mozart piano concerto, or a Bach fugue, I must confess that the need for revolutionary musical formations does not strike me as very pressing. Surely, it is the difficulty of coaxing sweet sounds out of the oboe, and the skill of the players in an orchestra, that enhance the value of the performance. Is the levelling process going to be applied to music, so that we can all reproduce synthetic sounds with equal facility? Heaven forbid!

There is a clear distinction between synthetic and electronic sound. Synthetic music would be written in the form of sound waves by super artist-draughtsmen and could be reproduced by sound-on-film methods. It is however outside the scope of this book.

An Electronic musical instrument is one in which the vibrations of sound are produced initially by electronic oscillations under the control of the performer; the oscillations or difference tones are then usually transduced by loudspeaker after suitable amplification. A description of many types of electric musical instruments is to be found in *The Oxford Companion to Music* by Scholes, and for those who require technical details, the book *Electronic Musical Instruments* by S. K. Lewer, published by *Electronic Engineering*, is strongly recommended.

Mr. Lewer has some very interesting things to say about sound and his description of the choir effect provides food for thought :

“Where several instruments of the same kind are playing in unison, the effect is not a mere multiplication of the sound intensity. The slightest difference in frequency between two nominally similar tones will result in a changing phase relationship, and while audible beats may not be produced between the fundamental tones, beats are almost certain to arise from the greater difference between their higher harmonics or partials. In the case of several violins playing in unison where the vibrato rates are different and possibly the mean frequencies and the partial frequencies are also different, the massed effect is one of peculiar beauty, resembling a choir of voices. Of all the tonal qualities of orchestral music, the choir effect is the most difficult to achieve in a single electronic instrument.”

This explanation throws a good deal of light on one aspect of the fascination of the choir effect. Another main element is the difference in tonal colour which exists between instruments of the same type

or even of the same make. Each celebrated make of piano has its own characteristic tone¹—Bechstein, Bluthner, Bosendorfer, Steinway, etc. ; in each case the quality of tone is related to the make and is quite distinct. Yet there is still a difference between similar instruments of the same make. In short, no two pianos have exactly the same tone, which means that there is a difference in the wave form and harmonic content of the sound. Similar differences occur in violins, clarinets, human voices, in fact in all instruments which produce music acoustically.

When a number of such instruments play or sing in unison, the formant tone by which the instrument is recognised remains, but the overtones blend in such a way that harshness is often cancelled out. The result is that a chorus of good voices or a section of good violins will produce better tone than a soloist of superior individual quality. At least this is the case with strings and voices. (It is less noticeable with wind instruments which are characterised by a more pronounced and piercing tone.) A church organ is a magnificent instrument, but it cannot give this subtle blending of overtones, and no electronic device has so far achieved it.

The effect of mounting several speakers in parallel for reproduction above 1000 cycles was tried, with a view to blending cone resonances on "chorus" lines. Similar units with different cones were used, and the results were smoother on full orchestra, but the effect was considered rather unnatural on solos. The writer is not a believer in removing ALL directional effect from loudspeaker reproduction ; after all, Gigli has a big voice, but his mouth is of normal dimensions.

It has already been explained in Chapter 17 how the tonal structure of musical tones varies with intensity and thus retains the interest of the ear during performance. This combination of tonal and dynamic change is missing in most of the electronic devices so far produced.

It is often said that musicians are conservative and therefore do not show reasonable interest in new devices but it would be nearer the truth to say that musical people will not desert instruments of proven beauty of tone for inventions which are lacking in one or more of the following essential qualities, already described :

1. Choir effect and phasing.
2. Blending of overtones and resonances.
3. Dynamic/tonal change.

Another advantage of acoustic musical instruments (apart from a large organ) is that they are always ready for use, and it is not necessary to plug into electric mains.

It cannot be denied that very rich tone colour can be achieved by electronic means, and the Novachord is probably the most successful invention embodying original tonal effects of great charm. Other instruments are described by Mr. Lewer in the book already cited.

¹ In other words, such instruments possess character.

ORGANS

In spite of the lukewarm reception so far given to electronic musical instruments, there is one field in which the success of electronic devices has been outstanding, and that is in the production of organs for church or cinema use.

This success may be due to the fact that an organ does not possess the true choir effect and the blending of overtones mentioned previously, and therefore the electronic type can be made almost to equal the acoustic instrument in all qualities except that of dynamic/tonal change. As volume is normally increased on the organ by coupling additional stops, the dynamic interest is easily retained and tonal monotony avoided.

A brief description of one English and one American system now follows, as being interesting examples of sound reproduction, the one being electrostatic and the other electromagnetic.

COMPTON ELECTRONE

Few musicians, apart from those intimately associated with production and installation of the instruments, could detect any difference in tone quality between the Electrone and a normal pipe organ, as all the usual stops and controls, including tremulant, are provided. Many of these instruments are in use in churches and chapels both in this country and abroad.

The organ uses rotary sinusoidal electrostatic generators invented and designed by Mr. L. E. A. Bourn. Wave forms which embody the tone structure of the various stops are arranged on the stators, and scanning forms are arranged on the rotors, Fig. 93.

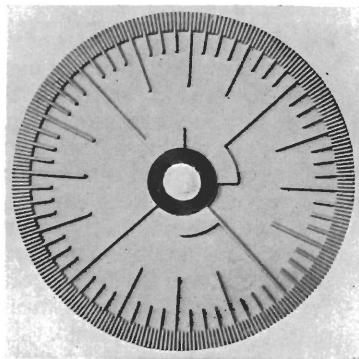
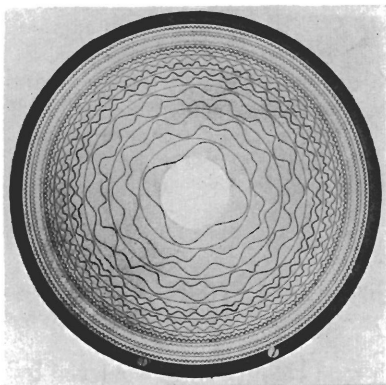

Courtesy John Compton Organ Co., Ltd.

FIG. 93.—Stator with wave formation of required tonal characteristics.

Rotor with scanning forms for collecting required tones from Stator.

There are twelve pairs of these discs, one pair for each semitone in the octave. The discs are all the same size and the semitone variations of pitch are achieved by twelve pulleys which control the speed of rotation of the rotors.

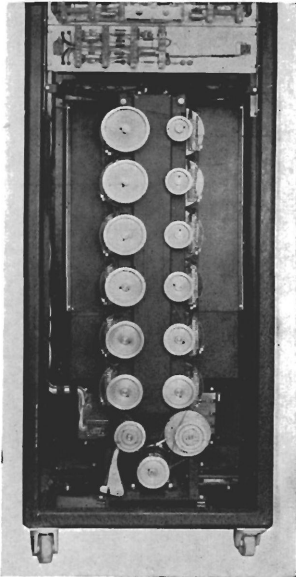

FIG. 94.—Compton Electrone.

View of 12 pulleys for controlling speed of rotors.

Bottom left—Jockey pulley.

Bottom right—Tremulant.

Bottom centre—Motor.

Each disc generates all the octaves of all tones required, and selection is by means of the lines on the rotor. Thus the disc for 32 cycles, bottom C, will give 8 ft. C at 64 cycles, Tenor C at 128 cycles, and so on over 8 octaves up to 8192 c.p.s. The keyboard, pedals and stops are exactly the same as a normal pipe organ, and the wave formations are calculated to form several variations of complex or formant tone. An infinite variety of overtones is achieved, and the tonal monotony of many electronic sound producers is thereby avoided.

The associated 40 Watt amplifier feeds two loudspeakers—an 18 inch unit for bass and a 12 inch for treble—with a frequency range of 32 to 12,000 cycles, including overtones. Ample volume for any church is available, and the price of the two-manual model is in the region of £1,500, about the same as a pipe organ with equivalent range of stops.

The two main advantages of this type of instrument are (a) it takes up less room than a comparable pipe organ and (b) frequent tuning is not required.

✻ A true “tremolo” is achieved by the special pulley which wavers the frequency when desired by the player, giving an excellent approximation of the vibrato effect produced by other musical instruments.

HAMMOND ORGAN

Produced in Chicago in 1935, this compact instrument met with immediate success and it is said that 3,000 had been sold in the U.S.A. by the end of 1937. The design lends itself to a certain amount of mass production, resulting in a reasonably low cost.

The fundamental tones and harmonics are produced by 91 generators in the form of metal discs each about $1\frac{1}{2}$ inches in diameter rotating at a constant speed close to a fixed electromagnet.

The following diagram shows one of these tone wheels along with its associated magnet, and also a much reduced view of the frame in which the 91 wheels are mounted.

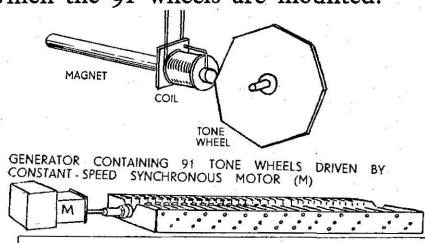

FIG. 95.—Hammond Organ.

Courtesy Boosey and Hawkes, London.

The frequency of the tone generated is determined by the number of high points on the disc, and the speed of rotation. The slowest tone wheels have two high points and the number is increased to 4, 8, 16, 32, 64 and 128 points. The speed varies from 960 to over 2500 revolutions per minute, giving a frequency range of approximately 32 to 6,000 c.p.s.

Each time a high point passes the magnet it varies the magnetic field and induces a flow of current in the coil. Thus a disc with 128 points rotating at 2500 r.p.m., say 42 revs per second, would produce a tone of 5376 cycles per second.

Although the highest tone generated by the discs is not above 6,000 cycles, this does not mean that higher frequencies are not produced and heard. The effect of summation tones when several notes and overtones are played will certainly produce very high frequencies for the ears of the listeners.

Eight harmonics are available for each fundamental, and as the seventh is omitted the highest harmonic used in each case is ten times the frequency of the fundamental. The seventh harmonic is omitted on account of its general harshness. The controls enable the player to select the power of the respective harmonics to give the tone-colour desired. The resulting "waves" are fed into an amplifier and loudspeaker system.

A form of "tremolo" is achieved by varying the attenuation of the signal before it reaches the main amplifier, and a "choir" effect can be introduced by switching in a separate set of generators of very low output geared to run slightly more slowly and more quickly than the main tone generators, thus producing rich beating effects.

CONCLUSION TO FIRST EDITION

There is one grave risk a writer takes in publishing his own work. It is the risk of riding his hobby-horse and putting into print a host of pet theories which no independent publisher would countenance. As I can think of nothing better calculated to ensure the failure of a book, I had to devise a plan for avoiding such pitfalls in the present volume. I took the hard course by writing pages and pages of padding to get it out of my system, and then consigning it to the waste-paper basket in my saner moments. I can only hope that the refining process has been carried out to the satisfaction of the reader.

Another risk is that a writer-publisher may "borrow" unduly from other publications. Any technical or semi-technical work which consisted only of the author's own experience would indeed be sparse fare, but there should be a reasonable balance between original and quoted matter. The present volume contains 118 diagrams or illustrations, made up as follows :

Original	70
From other publications	32
Proprietary (Commercial)	11
Historical	5

In view of the wide field covered, this may be looked upon as a fair proportion.

It should be made clear that the book is not intended as a text-book, and no responsibility can be assumed for facts or information which may have been overlooked or ignored in making the final selection of items to be included. Expressions of opinion are of course my own, but all statements of fact have been submitted to the appropriate authorities for confirmation before printing.

I was warned several times by well-wishers that in writing about pick-ups and needles I should be sticking my neck out. If this be so, then the protrusion contains at least a few of the vertebrae of the B.B.C., Decca, E.M.I., Watts, *et al.* In the words of one of the most illustrious Englishmen of all time—some neck. Frankly speaking, I do not think I have asked for trouble at all. I have merely tried to look into some of the problems associated with domestic reproduction of sound and set down the result of my work in the hope that it will interest those who derive much enjoyment in this life through the medium of the ear.

Music is still the only universal language; it is in ample supply to suit all tastes, and it pays rich dividends to those who cultivate its acquaintance.

CONCLUSION TO SECOND EDITION

It is no doubt unusual to find two conclusions in one book, but the first one has been left in because it contains a general summary which is still relevant.

One of the main difficulties in completing a book on sound reproduction is that progress is constantly being made. Improvements in one link in the chain are followed by refinements in others, which combine to make definite stages in development. Microgroove and magnetic recording mark two important post-war advances. It is impossible to predict what will follow in the wake of improved frequency response at slower speeds, or how the clean transient response of tape recording will affect the technique of disc recording.

There are welcome signs that the importance of transient response and wave form as distinct from mere frequency response is receiving due consideration. Although a square wave is a musical impossibility because of the time factor, the use of square waves in research is helping to solve many problems, and it may even prove that pick-ups which give the best audible results today are actually those which fail to reveal the transient shortcomings in recording. No doubt improved transients will in due course give us brighter reproduction without the annoyance still so often associated with maximum H.F. response.

REFERENCE TABLES

T	Tera	=	10 ¹²	=	Billion
G	Giga	=	10 ⁹	=	Milliard
M	Mega	=	10 ⁶	=	Million
K	Kilo	=	10 ³	=	Thousand
h	Hecta	=	10 ²	=	Hundred
D	Deca	=	10 ¹	=	Ten
d	Deci	=	10 ⁻¹	=	Tenth
c	Centi	=	10 ⁻²	=	Hundredth
m	Milli	=	10 ⁻³	=	Thousandth
μ	Micro	=	10 ⁻⁶	=	Millionth
n	Nano	=	10 ⁻⁹	=	Milliardth
p	Pico	=	10 ⁻¹²	=	Billionth

IN AMERICA AND FRANCE.

1 Billion = 10⁹
1 Trillion = 10¹²

LINEAL MEASURES.

	<i>in.</i>	<i>ft.</i>	<i>yd.</i>	<i>c.m.</i>	<i>metre</i>
1 inch ...	1	0.083	0.028	2.54	0.025
1 foot ...	12	1	0.333	30.48	0.305
1 yard ...	36	3	1	91.44	0.914
1 c.m. ...	0.394	0.03	0.01	1	—
1 metre ...	39.37	3.281	1.094	100	1

SQUARE MEASURES

	<i>sq. in.</i>	<i>sq. ft.</i>	<i>sq. yd.</i>	<i>c.m.²</i>	<i>m²</i>
1 square inch ...	1	—	—	6.452	—
1 square foot ...	144	1	0.111	929.2	0.093
1 square yard ...	1296	9	1	8363	0.836
1 c.m. ² ...	0.155	0.001	—	1	—
1 M ² ...	1550	10.76	1.196	—	1

WEIGHT

	<i>dram</i>	<i>ounce</i>	<i>lb.</i>	<i>g.</i>	<i>Kg.</i>
1 dram ...	1	0.0625	0.0039	1.772	—
1 ounce ...	16	1	0.0625	28.35	0.0284
1 pound ...	256	16	1	453.6	0.4536
1 gramme ...	0.564	0.0353	0.0022	1	—
1 Kilogramme ...	564	35.3	2.2046	1000	1

CUBIC MEASURES

	<i>cu. in.</i>	<i>cu. ft.</i>	<i>U.S. g.</i>	<i>Imp. g.</i>	<i>British fluid oz.</i>	<i>dm³</i>
1 cu. inch ...	1	—	0.0043	0.0036	0.5773	0.0164
1 cu. foot ...	1728	1	7.48	6.234	997.6	28.32
1 U.S. gallon ...	231	0.1336	1	0.833	133.4	3.785
1 Imp. gallon ...	277.3	0.1604	1.200	1	160.1	4.543
1 Brit. fl. oz. ...	1.732	0.001	0.007	0.006	1	0.0284
1 dm ³ ...	61.02	0.035	0.264	0.220	35.21	1

INDEX

A		Circuit, multi-speakers	42
Abrasive Tests	180	Classrooms	103
Absorption coefficients	98-9	Cleaning records	157
Acoustic Absorption	36	Coaxial Reflex	32
" Gramophone 154, 163, 208		Coil, Iron cored	126
" Recording	155	" Length	53
Air Loading	17, 52	" Resistance	125
Air Space around L.S.	91	" Winding data	128
Aluminium Voice Coil	83	Combination waves	105, 145
American Recording	161-2	Compton Electrone	238
Amplifier	163	Concrete Panel	86
" Crossover	112	Condenser, Resonance	119
" hum	214	Cone Resonance	127
Analysis, Sound	69-74	Corner Panel	34, 76
" Voice	69	Crooner	111
Anechoic Room	100	Crossover in Amplifier	112
Apertures	88	" Benefits	115
Area of Port	22, 28	" Circuits	116
Armatures	219	" Frequency	82, 90, 117, 125
Attenuation	89	" Half Section	123
" Crossover	113	" High Impedance	113
" H.F.	120-1	" Quarter Section	121
" L.F.	117-9	" Networks	112
" of Sound	97	Crystal Pick-up	217
" Tweeter	124	Cutting speeds	184
B		Cymbals, recorded	169, 198
Baffles	26	D	
" Infinite	71	Dead room	99
" Treble	76	Decca characteristic	160
Bass, true	67	Delayed resonance	93
Berliner Disc	152	Density List	44
Bias	142-3	" minimum	48
" H.F.	144-5	Diamond	181-2
" Response	146	Diaphragm, Metal	65
Brick Reflex	75	Diffuser, Lens	78-9
B.B.C. Equipment	174	" Slot	77
" Library	175	Direct Recording	168
" Pick-ups	176	Directional Effects	77
" Recording	172, 175	Disc Recording	129
" Response	175	Distortion	105, 109, 164, 206
" Turntable Drive	174	" Crossover	127
Buchmann-Meyer	166-7	Drive	146
C		Dual Track	147
Cabinets	17	Duralumin	66
" with Baffles	36	Dust	157
" closed	24-5	Dynamic Pick-ups	217
" depth	24	" Range	110
" height	27	E	
" lining	49	Ear	97
" odd shapes	21	Edison	151
" reflex	17-19	Electrical Recording	156
" resonance	56-8	Electronic Pick-up	218
" small	87	" Sound	236
" square	19	E.M.I. Recorder	148
Choir effect	41, 237		

Excel Recorder 149
 Exponential Horn .. 38, 39, 154

F

Factory Noise 97, 224
 Featherweight Pick-ups .. 220
 Feedback, Acoustic 214
 " Negative 74, 164
 Fibres 187-8
 Film Recording 131
 Filters 112
 Flutter 206
 Free-field rooms 98-101
 Frequencies, Recorded
 136, 148, 163, 175, 184, 228
 Frequency doubling .. 53, 69-74
 " Range 62
 Fundamental Tones 68

G

Gaps 140
 Gap Length 53
 " Response 138-9
 Groove Location 221-3
 " Radius 185
 " Width 185
 Grooves 183
 " per inch 175

H

Hammond Organ 240
 Harmonic Analysis .. 20, 69, 110
 Head-multiple 139
 H.F. Production 64
 High-note Systems 25
 Horn, Bass 39
 " Exponential .. 38-9, 154
 Hum 209, 214
 Hysteresis 142

I

Impedance 29, 30, 83
 " Curves 122-3
 " Matching 90
 " Multi-speakers .. 43
 " Various 126
 Inductance, Voice coil .. 119
 " Winding data .. 128
 Infinite Baffle 71
 Instability 89
 Intermodulation 105
 Internal pipe 31

L

Lacquer 156
 " Disc 169-171

Lining 49-50
 " Felt 59
 " Horns 51
 " Reflex 91
 Listening Test 63-4
 Loading, double 87
 Location of sound 97
 " speakers 103
 L.F. Output 209
 " performance 54
 " response 31
 Low-level coverage 103

M

Magnetic Recording 129
 Magnetising, Heads .. 142
 " Methods 137
 Matched Resonance .. 26, 29, 88
 Megaphones 56
 Microgroove 165, 226
 " Characteristic .. 226
 " Quality 232
 " Tone Control .. 227
 Monitor 90
 Motor board Vibration .. 213
 " Noise 207, 209, 212
 Mounting—speakers .. 58, 85
 Multiple Speakers .. 40-3, 89

N

N.A.B. Characteristic .. 161-2
 Needle Inspection 202
 " Polish 181
 " Scratch 211
 " Wear 181, 214, 232
 " Weight 181
 Needles and Grooves .. 183
 Negative Feedback .. 74, 164
 Noise Level 141

O

Orchestral Range 67-68
 Organs 238
 Organ Pipe 55
 Oscillographs 96
 Oval Tip 185
 Overhang 205
 Overtones 52

P

Panel, Corner 76
 Parallel mounting 21, 92
 Path Length 56, 88
 Phase Effects 97
 Phasing 124

INDEX

Phillips Miller	131
Phonograph	151
Photographic Recording ..	130
Photomicrographs	169, 180, 229
Piano, Harmonics	110
" Record	229-30
" Wave form	96
Pick-ups	215-218
Pinch Effect	203
Pipe	22
" Folded	37
" Tapered	35, 37
Playing Time	141
Polish	181
Porosity	178
Port, Area	22, 28, 29
" Position	31
Poulsen	133
Power Loss	120
Processing	158
Psychological Effects	68

Q

Questions and Answers	84
-----------------------------	----

R

R.C.A. Record Player	235
Radius Compensation	163
Reactance	114-115
Recording Characteristic ..	160, 161, 226
Reference Tables	243
Reflection Coefficient	98, 99
Reflector	19
Reflex, Brick	75
" Cabinet	18, 19
" Non-resonant	33, 34
" Pipe	21, 22
Remanence Curve	143
Resonance	17-19, 30, 56-8, 66
" Bass	84
" Crossover	118
" Delayed	93
" Tweeter	124
" Violin	111
Response	84, 85
" Baffles	26
" Bass	31, 52
" B.B.C.	175
" Cabinets	23-25
" Curves	58-61, 94-95
" Radius	162
" Tape	136, 137
" Wire	136
Reverberation	51, 102
Ribbon Speakers	80
Rumble	212

S

Sapphire	177-190
" Chipped	193
" Used	194-5
Schools	103
Shadowgraph	178
Shape of Point	185
Signal to Noise Ratio	224
Size of Cavity	92
Sound Absorption	102
" Attenuation	97
" Discrimination	97
" Location of	97
Sound box	153
Sound-Magnet Recorder	150
Spaciousness	53
Speaker mounting	58, 85
Spectrum-Noise	211
Speed Wire Tape	140-1
Steel Needles	189
Stereophonic System	62-3
Surface Noise	156, 207, 209, 225
" Speed	173

T

Tape Recorder, Diagram	135
Three Speakers	82
Tone-arm	219
" length	205
" resonance	204
Tone Control	127
Tones, Difference	67
" Summation	65
Tracing	206
Tracking Error	204
Transients	83
Tweeter	82, 124
Tungsten-Carbide	179
Turntables	218
Two Speakers	86

V

Vibration	30, 45-47, 209
Vinylite	156, 232-3
Violin, Resonance	111

W

Wall Mounting	87
" Treatment	99, 102
Wave Envelope	96, 105
Wavelength	184, 197, 228
Wear of Record	197, 228
Wow	142, 203

Y

Young's Modulus	65, 66
-------------------------	--------